

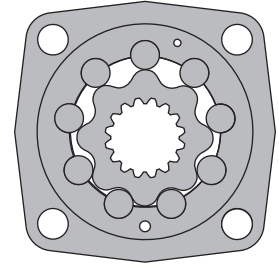

APPLICATION

- » Conveyors
- » Metal working machines
- » Agricultural machines
- » Road building machines
- » Mining machinery
- » Food industries
- » Special vehicles
- » Plastic and rubber machinery etc.

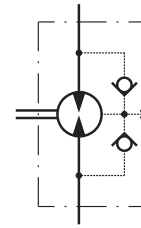

CONTENTS

Specification data	39
Function diagrams	41÷43
Permissible shaft loads	43
Dimensions and mounting	44÷46
Dimensions and mounting - MVS	47
Dimensions and mounting - MVV	48
Internal Spline data	49
Tacho connection.....	49
Shaft extensions	50
Order code	50

OPTIONS

- » Model - Disc valve, roll-gerotor
- » Flange and wheel mount
- » Short motor
- » Tacho connection
- » Speed sensing
- » Side ports
- » Shafts - straight, splined and tapered
- » BSPP ports
- » Other special features

GENERAL

Max. Displacement, cm ³ /rev [in ³ /rev]	801,8 [48.91]
Max. Speed, [RPM]	630
Max. Torque, daNm [lb-in]	cont.: 188 [16650] int.: 211 [18650]
Max. Output, kW [HP]	64 [85,8]
Max. Pressure Drop, bar [PSI]	cont.: 200 [2900] int.: 240 [3480]
Max. Oil Flow, lpm [GPM]	240 [63.4]
Min. Speed, [RPM]	5
Permissible Shaft Loads daN [lbs]	P _a =1500 [3300]
Pressure fluid	Mineral based- HLP(DIN 51524) or HM(ISO 6743/4)
Temperature range, °C [°F]	-40÷140 [-40÷284]
Optimal Viscosity range, mm ² /s [SUS]	20÷75 [98÷347]
Filtration	ISO code 20/16 (Min. recommended fluid filtration of 25 microns)

Oil flow in drain line

Pressure drop bar [PSI]	Viscosity mm ² /s [SUS]	Oil flow in drain line lpm [GPM]
140 [2030]	20 [98]	3 [.793]
	35 [164]	2 [.528]
210 [3045]	20 [98]	6 [1.585]
	35 [164]	4 [1.057]

Pressure Losses

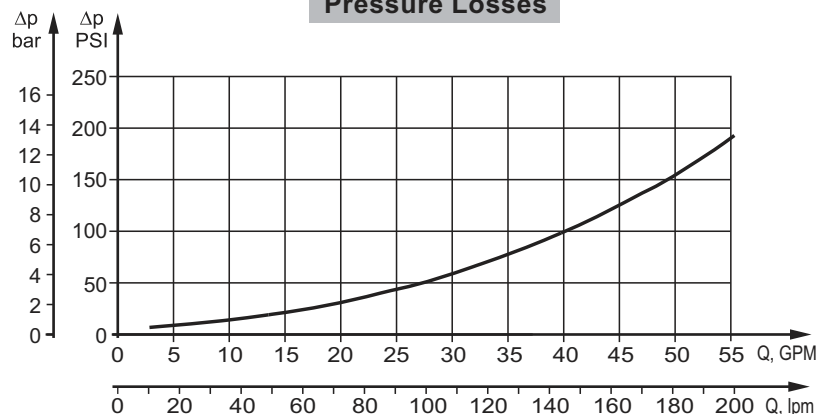

SPECIFICATION DATA

Type		MV 315	MV 400	MV 500	MV 630	MV 800
Displacement, cm³/rev [In³/rev]		314,5 [19.18]	400,9 [24.45]	499,6 [30.48]	629,1 [38.38]	801,8 [48.91]
Max. Speed, [RPM]	Cont.	510	500	400	320	250
	Int.*	630	600	480	380	300
Max. Torque daNm [lb-in]	Cont.	92 [8150]	118 [10450]	146 [12950]	166 [14700]	188 [16650]
	Int.*	111 [9800]	141 [12500]	176 [15550]	194 [17150]	211 [18650]
	Peak**	129 [11400]	164 [14500]	205 [18150]	221 [19550]	247 [21850]
Max. Output kW [HP]	Cont.	42,5 [57]	53,5 [71.7]	53,5 [71.7]	48 [64.4]	42,5 [57]
	Int.*	51 [68.4]	64 [85.8]	64 [85.8]	56 [75]	48 [64.4]
Max. Pressure Drop bar [PSI]	Cont.	200 [2900]	200 [2900]	200 [2900]	180 [2610]	160 [2320]
	Int.*	240 [3480]	240 [3480]	240 [3480]	210 [3050]	180 [2610]
	Peak**	280 [4060]	280 [4060]	280 [4060]	240 [3480]	210 [3050]
Max. Oil Flow lpm [GPM]	Cont.	160 [42.3]	200 [52.8]	200 [52.8]	200 [52.8]	200 [52.8]
	Int.*	200 [52.8]	240 [63.4]	240 [63.4]	240 [63.4]	240 [63.4]
Max. Inlet Pressure bar [PSI]	Cont.	210 [3050]	210 [3050]	210 [3050]	210 [3050]	210 [3050]
	Int.*	250 [3620]	250 [3620]	250 [3620]	250 [3620]	250 [3620]
	Peak**	300 [4350]	300 [4350]	300 [4350]	300 [4350]	300 [4350]
Max. Return Pressure with Drain Line bar [PSI]	Cont.	140 [2040]	140 [2040]	140 [2040]	140 [2040]	140 [2040]
	Int.*	175 [2540]	175 [2540]	175 [2540]	175 [2540]	175 [2540]
	Peak**	210 [3050]	210 [3050]	210 [3050]	210 [3050]	210 [3050]
Max. Starting Pressure with Unloaded Shaft, bar [PSI]		8 [120]	8 [120]	8 [120]	8 [120]	8 [120]
Min. Starting Torque daNm [lb-in]	At max. press. drop Cont.	71 [6300]	91 [8100]	113 [10000]	133 [11800]	151 [13400]
	At max. press. drop Int.*	85 [7500]	109 [9600]	136 [12000]	155 [13700]	170 [15000]
Min. Speed***, [RPM]		10	9	8	6	5
Weight, kg [lb]	MV	31,8 [70.1]	32,6 [71.9]	33,5 [73.8]	34,9 [76.9]	36,5 [80.5]
	MVW	32,4 [71.4]	33,2 [73.2]	34,1 [75.2]	35,5 [78.3]	37,1 [81.8]
	MVS	22,7 [50]	23,5 [51.8]	24,4 [53.8]	25,6 [56.4]	27,7 [61.1]

* Intermittent operation: the permissible values may occur for max. 10% of every minute.

** Peak load: the permissible values may occur for max. 1% of every minute.

*** For speeds lower than given, consult factory or your regional manager.

1. Intermittent speed and intermittent pressure must not occur simultaneously.
2. Recommended filtration is per ISO cleanliness code 20/16. A nominal filtration of 25 micron or better.
3. Recommend using a premium quality, anti-wear type mineral based hydraulic oil HLP(DIN51524) or HM (ISO 6743/4).
If using synthetic fluids consult the factory for alternative seal materials.
4. Recommended minimum oil viscosity 13 mm²/s [70 SUS] at 50°C [122°F].
5. Recommended maximum system operating temperature is 82°C [180°F].
6. To assure optimum motor life fill with fluid prior to loading and run at moderate load and speed for 10-15 minutes.

FUNCTION DIAGRAMS

MV 315

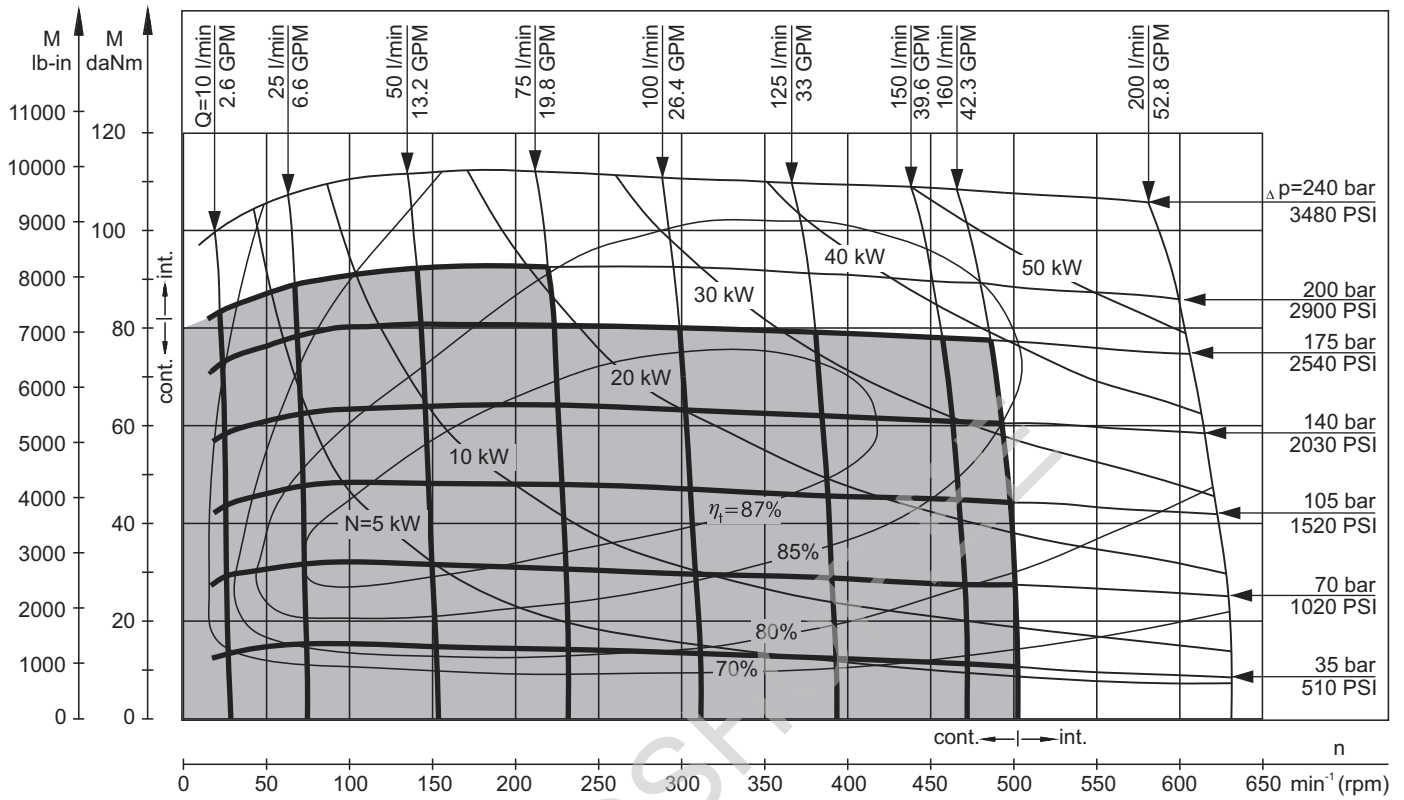

MV 400

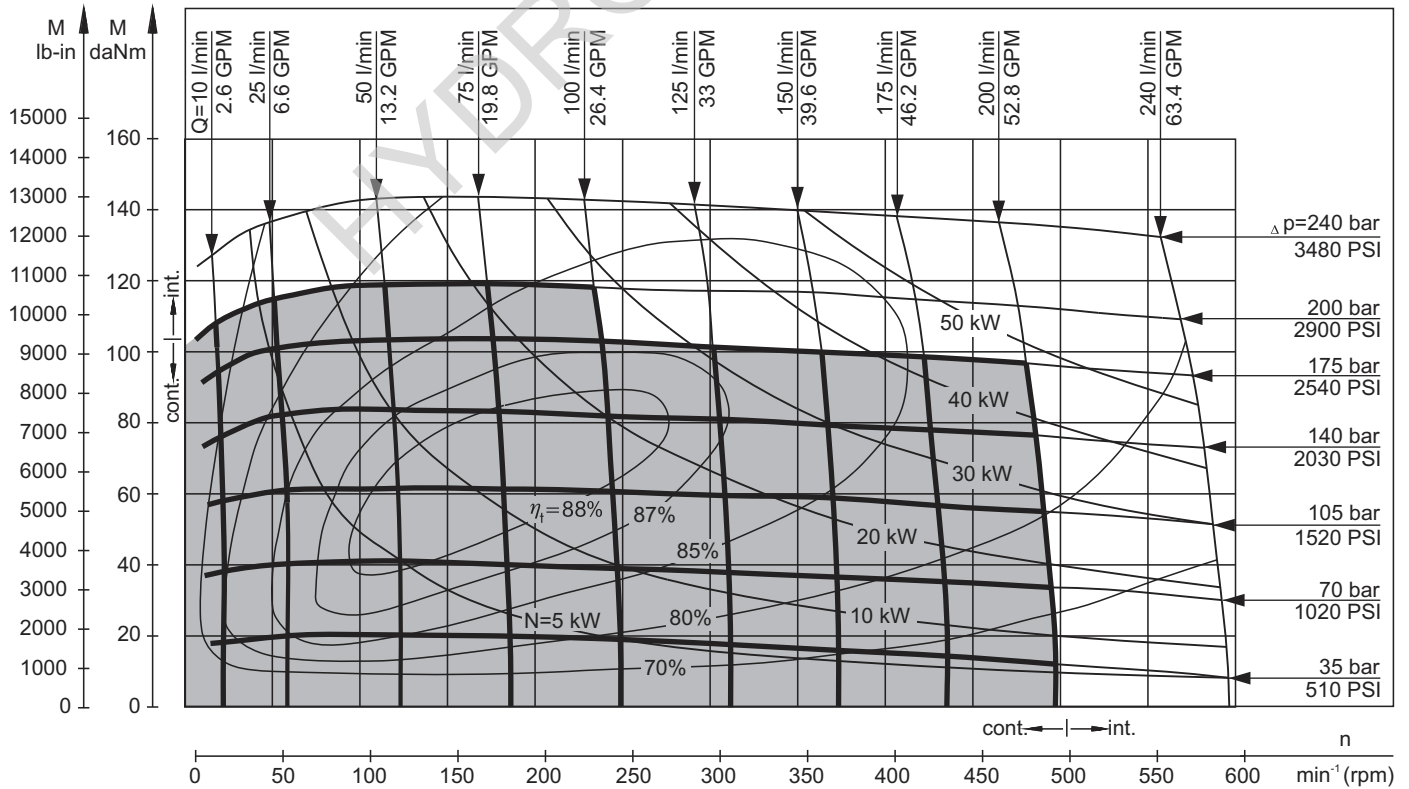

The function diagrams data is for average performance of randomly selected motors at back pressure 5 ÷ 10 bar [72.5 ÷ 145 PSI] and oil with viscosity of 32 mm²/s [150 SUS] at 50°C [122°F].

FUNCTION DIAGRAMS

MV 500

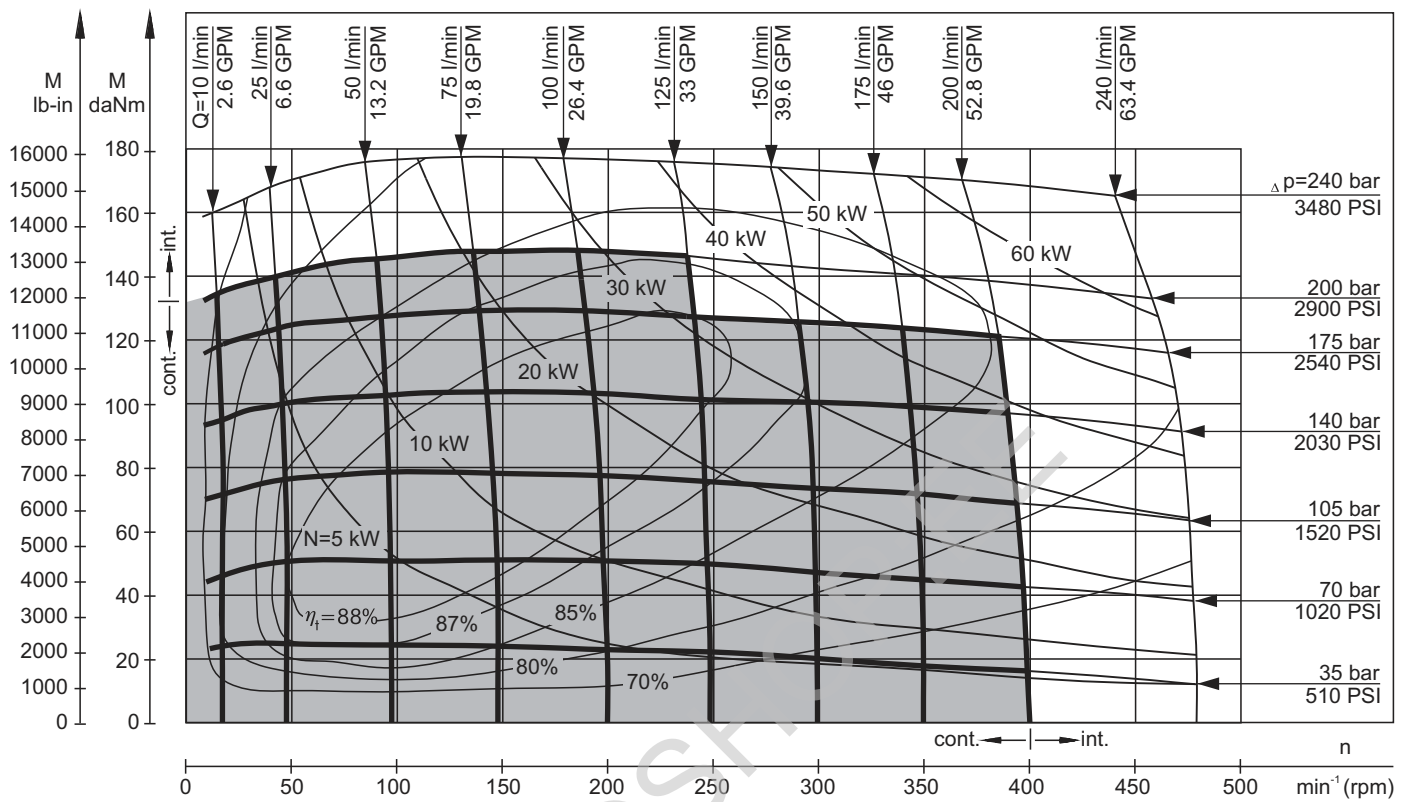

MV 630

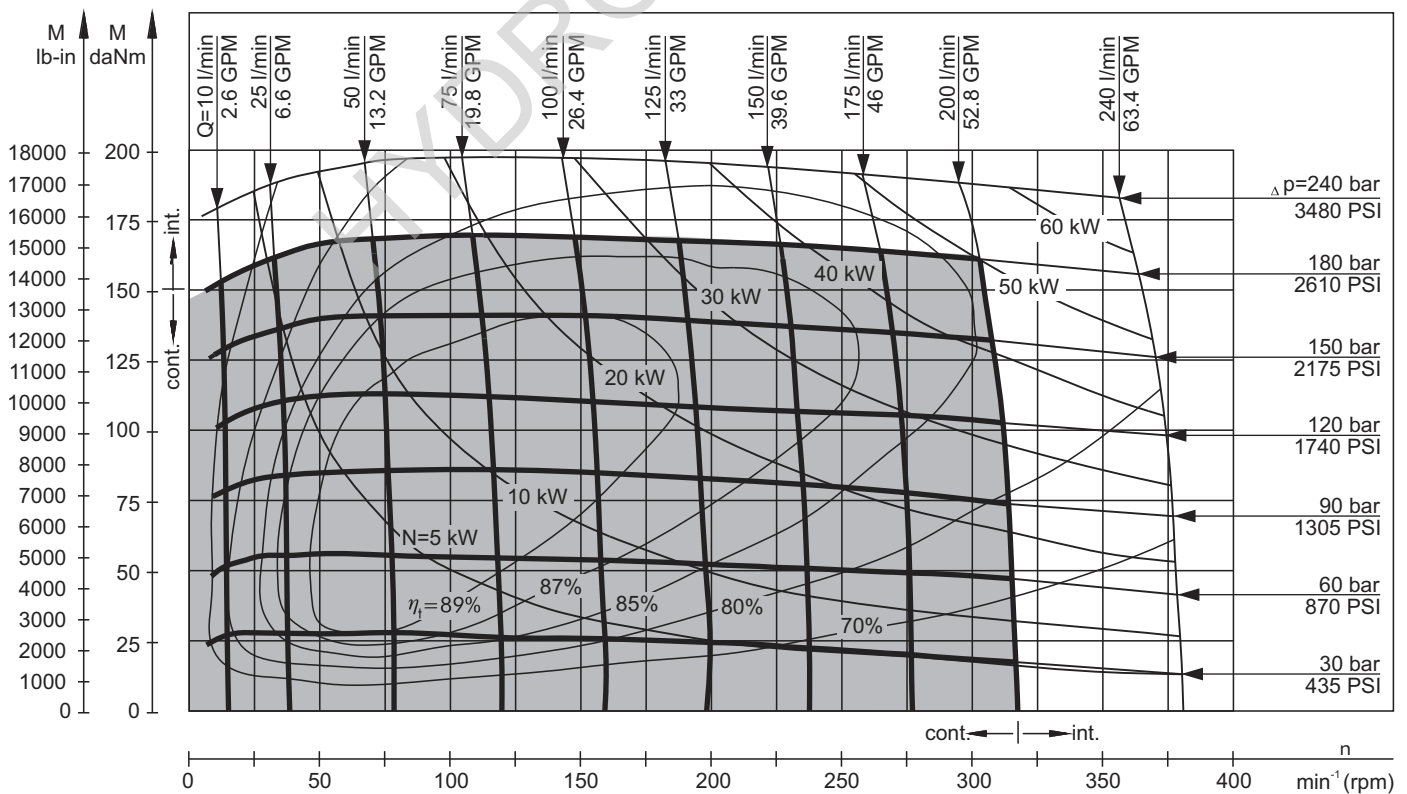

The function diagrams data is for average performance of randomly selected motors at back pressure $5 \div 10$ bar [72.5 \div 145 PSI] and oil with viscosity of $32 \text{ mm}^2/\text{s}$ [150 SUS] at 50°C [122°F].

FUNCTION DIAGRAMS

MV 800

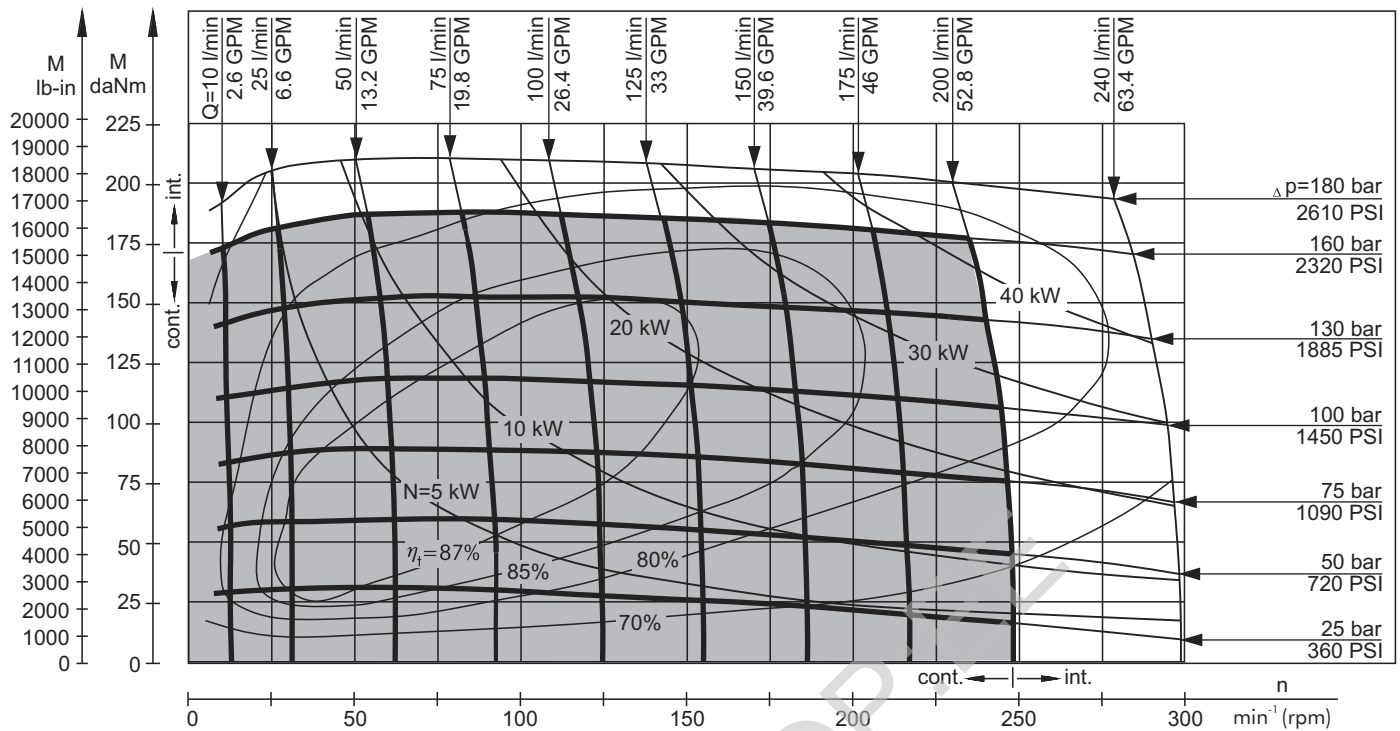

The function diagrams data is for average performance of randomly selected motors at back pressure 5 ± 10 bar [72.5 \pm 145 PSI] and oil with viscosity of 32 mm²/s [150 SUS] at 50°C [122°F].

PERMISSIBLE SHAFT LOADS

The output shaft runs in tapered bearings that permit high axial and radial forces. The permissible radial load on the shaft is shown for an axial load of 0 N as function of the distance from the mounting flange to the point of load application. The curves apply to a B10 bearing life of 2000 hours at 100 RPM.

Curve "1" shows max. radial shaft load. Any shaft load exceeding the values shown by the curve will seriously reduce motor life.

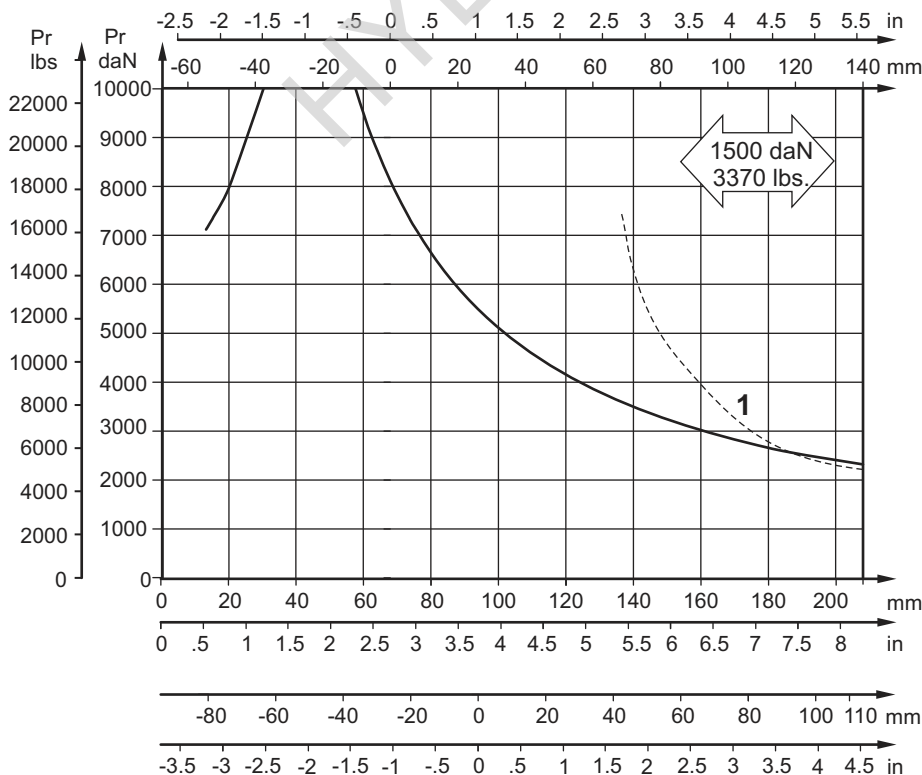

Mounting Flange:

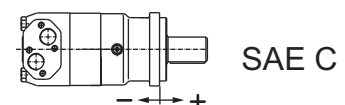
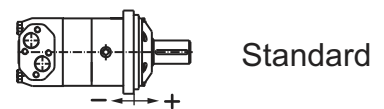

DIMENSIONS AND MOUNTING DATA - MV and MVC

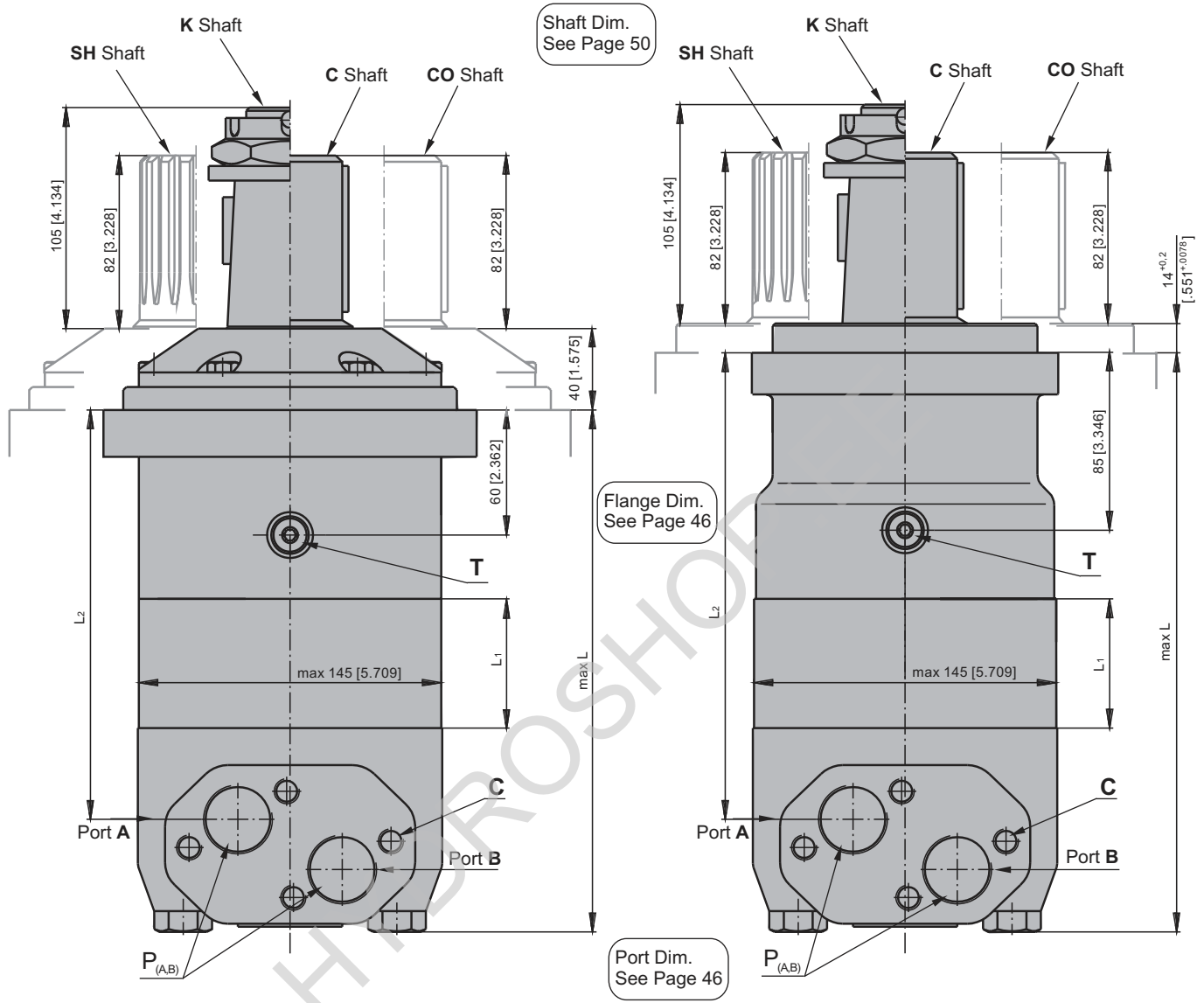

C: 4xM12 - 12 mm [.47 in] depth
P_(A,B): 2xG1 - 20 mm [.79 in] depth
T: G 1/4 - 12 mm [.47 in] depth

Standard Rotation
 Viewed from Shaft End
 Port A Pressurized - **CW**
 Port B Pressurized - **CCW**

Reverse Rotation
 Viewed from Shaft End
 Port A Pressurized - **CCW**
 Port B Pressurized - **CW**



Type	L, mm [in]	L2, mm [in]	Type	L, mm [in]	L2, mm [in]	*L1, mm [in]
MV 315	214,5 [8.45]	160[6.30]	MVC 315	238,25 [9.38]	184,26 [7.25]	22,0 [.87]
MV 400	221,5 [8.72]	167[6.58]	MVC 400	245,25 [9.66]	191,26 [7.53]	29,0 [1.14]
MV 500	229,5 [9.04]	175[6.89]	MVC 500	253,25 [9.97]	199,26 [7.85]	37,0 [1.46]
MV 630	240,0 [9.45]	186[7.32]	MVC 630	263,75 [10.38]	209,76 [8.25]	47,5 [1.87]
MV 800	254,0 [10.0]	200[7.87]	MVC 800	277,75 [10.94]	223,76 [8.81]	61,5 [2.42]

* The width of the roll-gerotor is 4 mm [.157 in.] greater than L1.

DIMENSIONS AND MOUNTING DATA - MVW

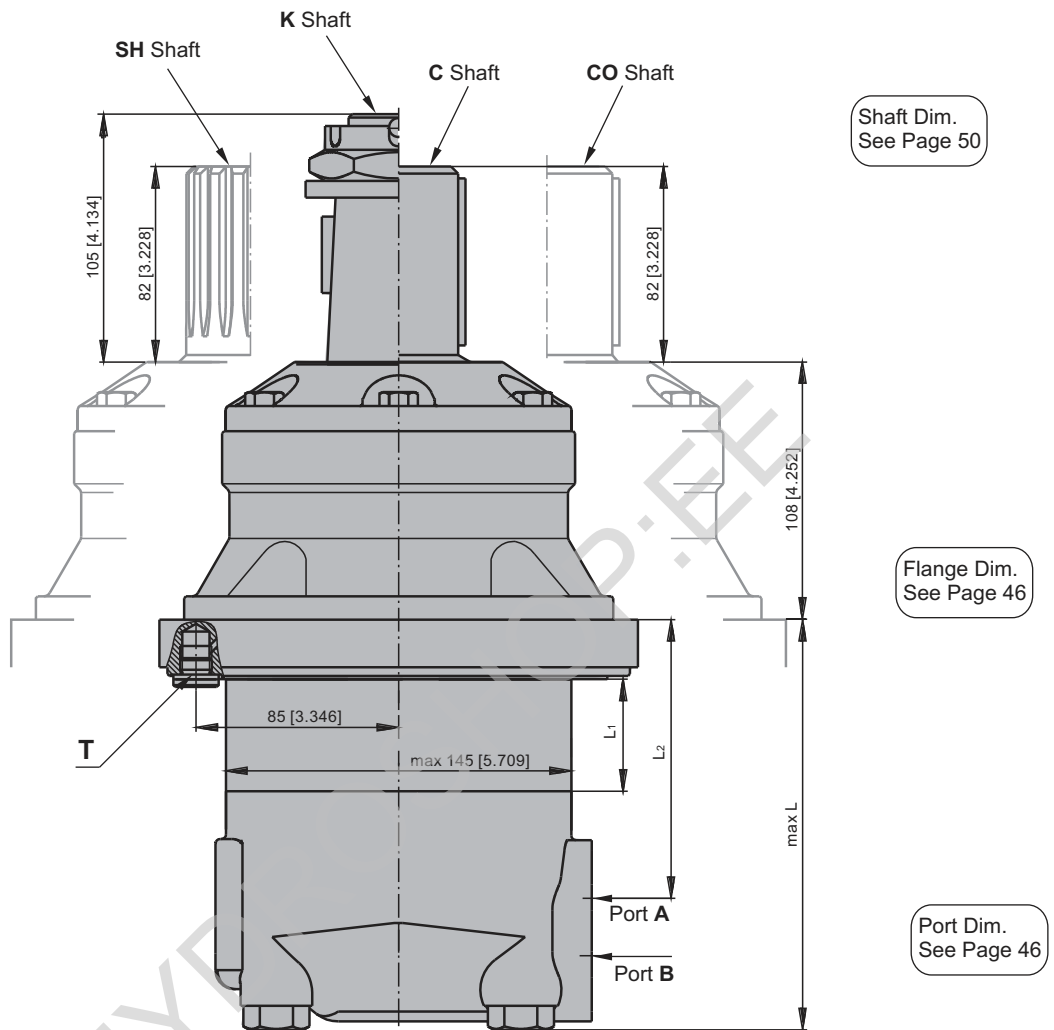

- C: 4xM12 - 12 mm [.47 in] depth
- P_(A,B): 2xG1 - 20 mm [.79 in] depth
- T: G 1/4 - 12 mm [.47 in] depth

Standard Rotation
Viewed from Shaft End
Port A Pressurized - **CW**
Port B Pressurized - **CCW**

Reverse Rotation
Viewed from Shaft End
Port A Pressurized - **CCW**
Port B Pressurized - **CW**



Type	L, mm [in]	L2, mm [in]	*L1, mm [in]
MVW 315	146 [5.75]	92 [3.62]	22,0 [.87]
MVW 400	153 [6.02]	99 [3.90]	29,0 [1.14]
MVW 500	161 [6.34]	107 [4.21]	37,0 [1.46]
MVW 630	172 [6.77]	118 [4.65]	47,5 [1.87]
MVW 800	185 [7.28]	132 [5.20]	61,5 [2.42]

* The width of the roll-gerotor is 4 mm [.157 in.] greater than L1.

MOUNTING

Square Mount (4 Holes)

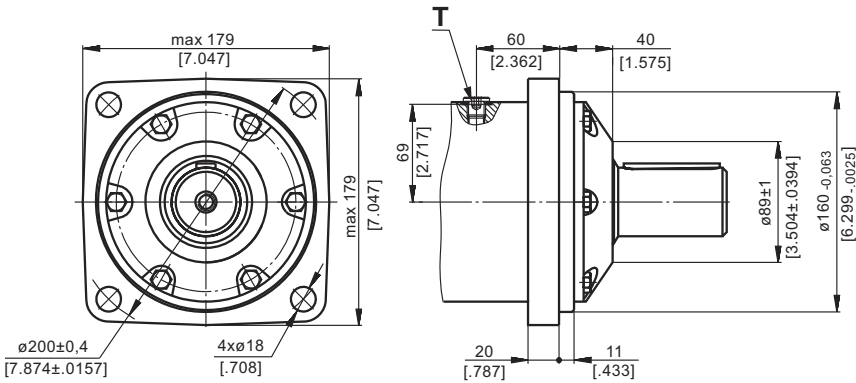

C SAE C Mount

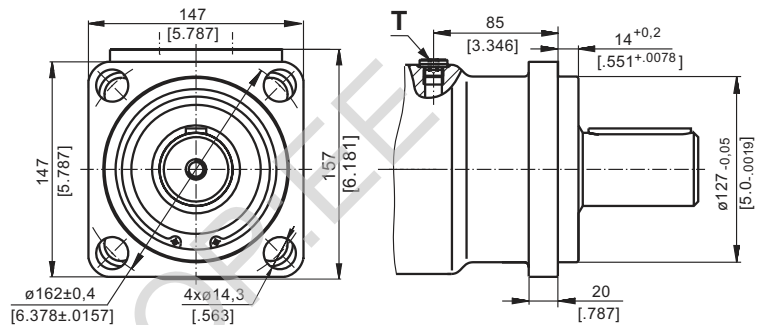

W Wheel Mount

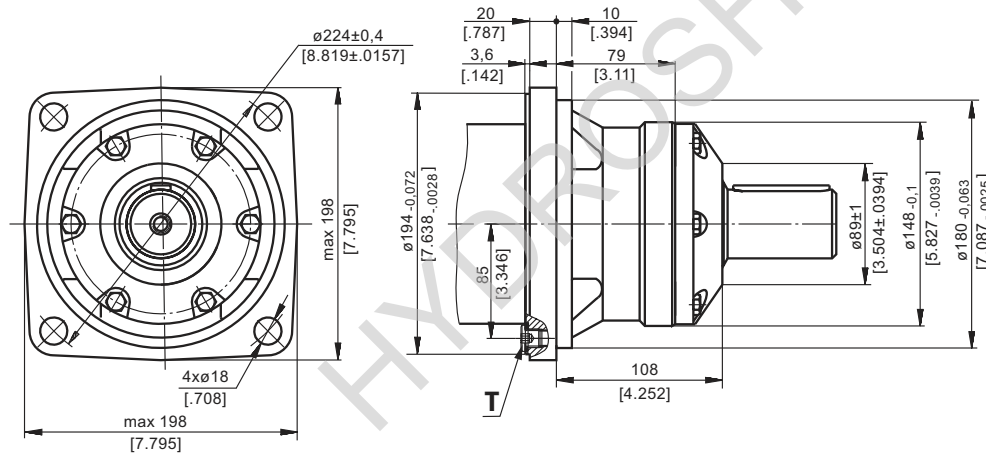

PORTS

Side Ports

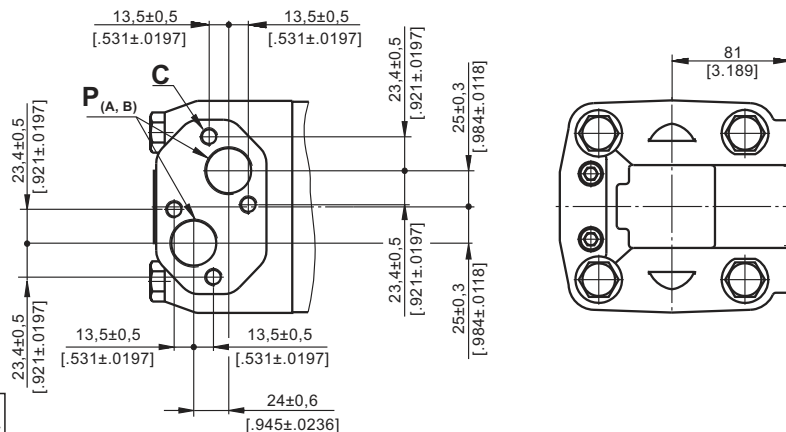

- C:** 4xM12 - 12 mm [0.47 in] depth
- P_(A,B):** 2xG1 - 20 mm [0.79 in] depth
- T:** G 1/4 - 12 mm [0.47 in] depth

Standard Rotation
Viewed from Shaft End
Port A Pressurized - **CW**
Port B Pressurized - **CCW**

Reverse Rotation
Viewed from Shaft End
Port A Pressurized - **CCW**
Port B Pressurized - **CW**



DIMENSIONS AND MOUNTING

S Short Mount

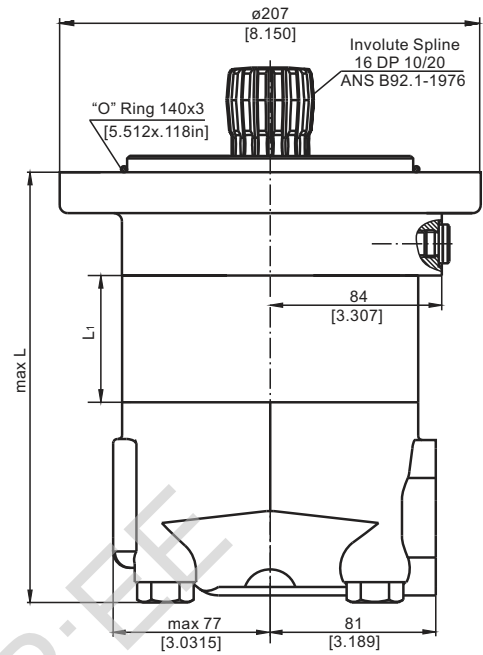
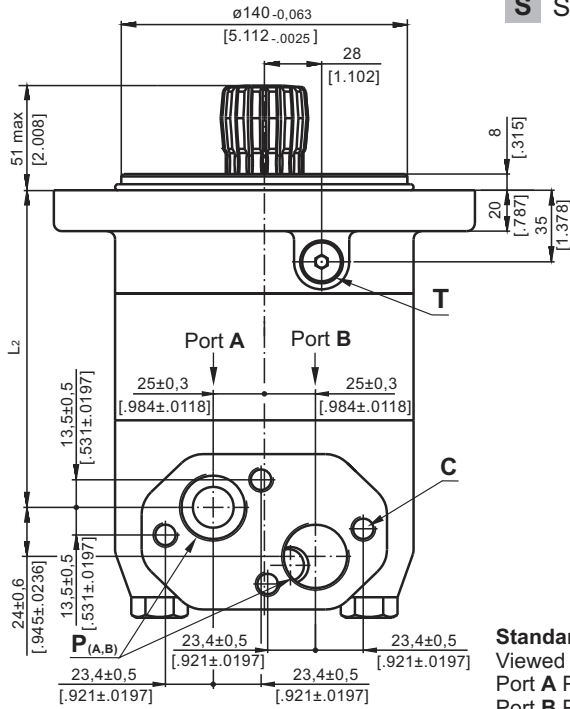

- C:** 4xM12 - 12 mm [.47 in] depth
- P_(A,B):** 2xG1 - 20 mm [.79 in] depth
- T:** G 1/4 - 12 mm [.47 in] depth

- Standard Rotation**
Viewed from Shaft End
Port A Pressurized - CW
Port B Pressurized - CCW
- Reverse Rotation**
Viewed from Shaft End
Port A Pressurized - CCW
Port B Pressurized - CW

Type	L, mm [in]	L2, mm [in]	*L1, mm [in]
MVS 315	171[6.73]	117[4.61]	22,0 [.87]
MVS 400	179[7.05]	124[4.88]	29,0 [1.14]
MVS 500	186[7.32]	132[5.20]	37,0 [1.46]
MVS 630	197[7.76]	143[5.63]	47,5 [1.87]
MVS 800	211[8.31]	157[6.18]	61,5 [2.42]

* The width of the roll-gerotor is 4 mm [.157 in] greater than L1.

DIMENSIONS OF THE ATTACHED COMPONENT

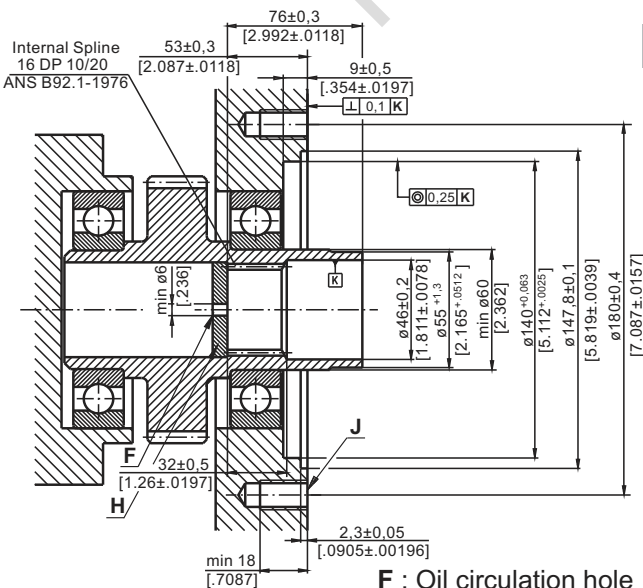

MVS

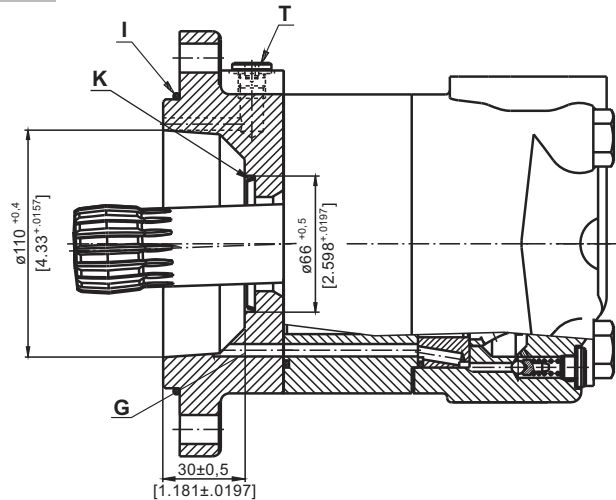

- F :** Oil circulation hole
- G :** Internal drain channel
- H :** Hardened stop plate
- I :** O-Ring 140x3mm [5.512x.118in]

- J :** 4xM12-18 mm [.709 in] depth, 90°
- K :** Conical seal ring
- T :** Drain connection G1/4 - 12 mm [.47 in] depth

DIMENSIONS AND MOUNTING

V Very Short Mount

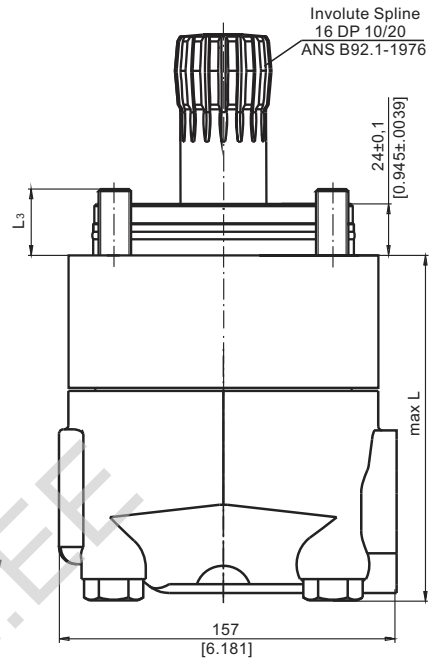
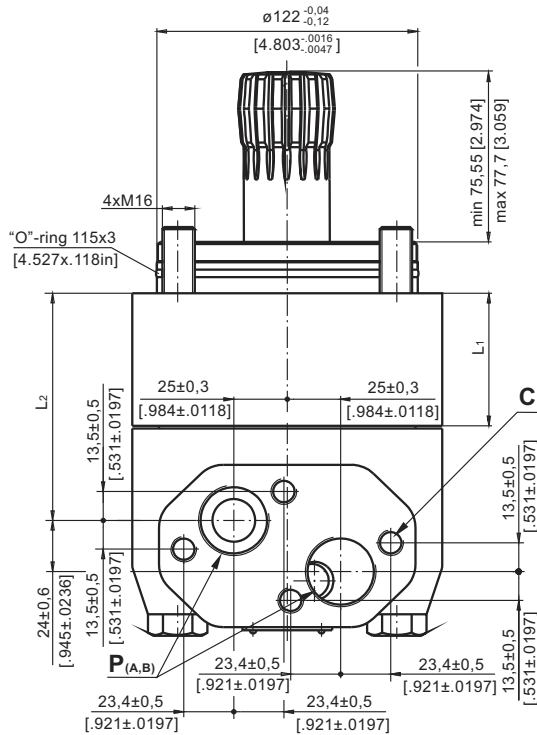

Standard Rotation
 Viewed from Shaft End
 Port A Pressurized - CW
 Port B Pressurized - CCW
Reverse Rotation
 Viewed from Shaft End
 Port A Pressurized - CCW
 Port B Pressurized - CW

C: 4xM12 - 12 mm [0.47 in] depth
P_(A,B): 2xG1 - 20 mm [0.79 in] depth

Type	L, mm[in.]	L2, mm [in.]	L3, mm [in.]	*L1, mm [in.]
MVV 315	121,5[4.78]	68[2.68]	29,5[1.16]	22,0 [0.87]
MVV 400	128,5[5.06]	75[2.95]	32,5[1.28]	29,0 [1.14]
MVV 500	136,5[5.37]	83[3.27]	34,5[1.36]	37,0 [1.46]
MVV 630	147,0[5.79]	93[3.66]	34,0[1.34]	47,5 [1.87]
MVV 800	161,0[6.34]	107,5[4.23]	30,0[1.18]	61,5 [2.42]

* The width of the roll-gerotor is 4 mm [0.157 in] greater than L1.

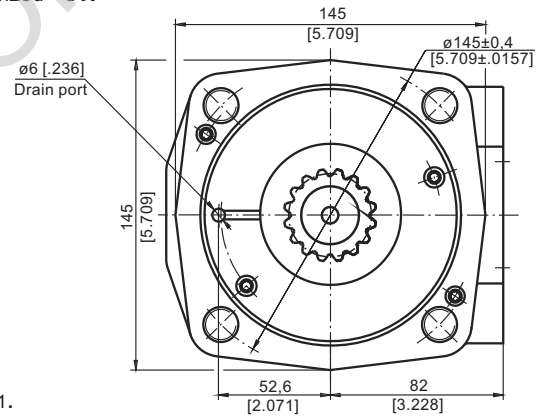

DIMENSIONS OF THE ATTACHED COMPONENT

MVV

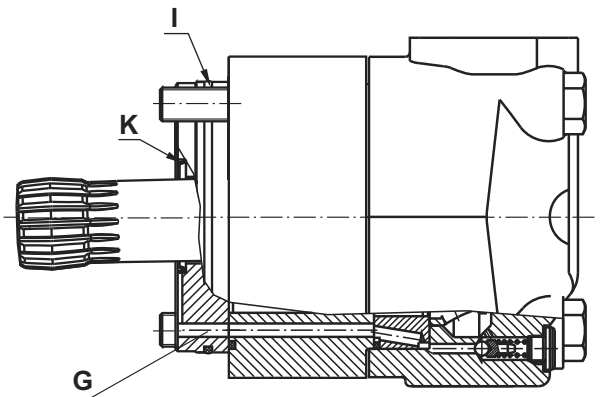
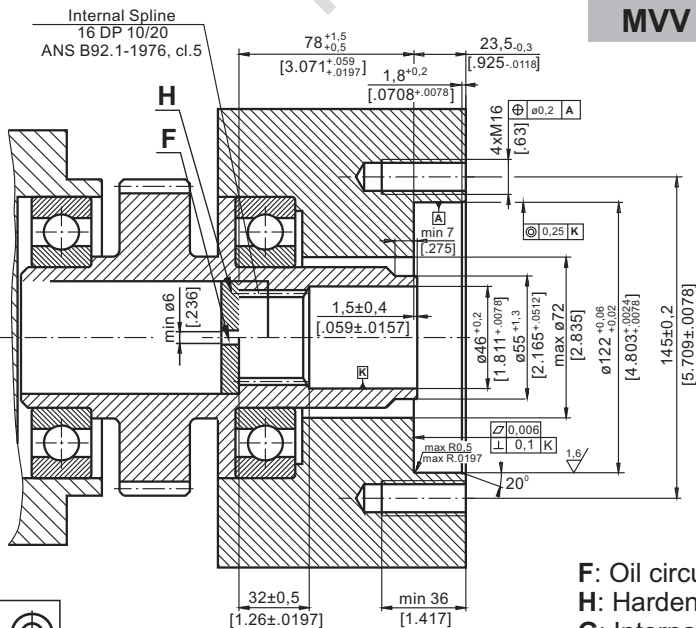

F: Oil circulation hole
H: Hardened stop plate
G: Internal drain channel

I: O-Ring 115x3mm [4.527x.118in]
K: Conical seal ring



DRAIN CONNECTION

A drain line has to be used when pressure in the return line can exceed the permissible pressure. It can be connected:

- For MVS to the drain port of the motor;
- For MVV to the drain connection of the attached component. The maximum pressure in the drain line is limited by the attached component and its shaft seal.

The drain line must be possible for oil to flow freely between motor and attached component and must be led to the tank. The maximum pressure in the drain line is limited by the attached component and its seal.

INTERNAL SPLINE DATA FOR THE ATTACHED COMPONENT

Standard ANS B92.1-1976, class 5
[$m=2.54$; corrected $x.m=+1,0$]

Fillet Root Side Fit		mm	inch
Number of Teeth	z	16	16
Diametral Pitch	DP	10/20	10/20
Pressure Angle		30°	30°
Pitch Dia.	D	40,640	1.6
Major Dia.	D _{ri}	45,2 ^{+0,4}	1.796±1.780
Minor Dia.	D _i	38,5 ^{+0,039}	1.5175±1.516
Space Width [Circular]	Lo	5,18±0,037	.2055±.2025
Fillet Radius	R	0,4	.015
Max. Measurement between Pins	L	32,47 ^{+0,15}	1.284±1.278
Pin Dia.	d	5,6±0,001	.22051±.22043

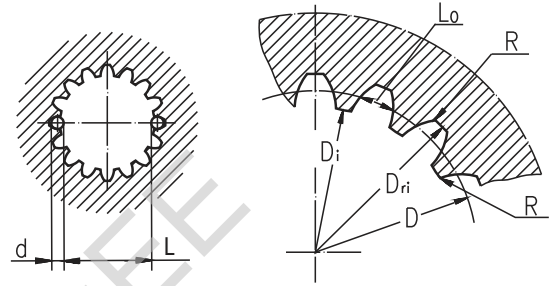

Hardening Specification:
 HV=750±50 on the surface.
 HV=560 at 0,7±0,2 mm [.035±.019in] case depth
 Material: 20 MoCr4 EN 10084 or better.

MOTOR WITH TACHO CONNECTION

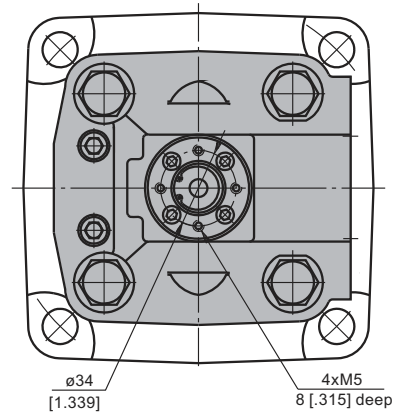
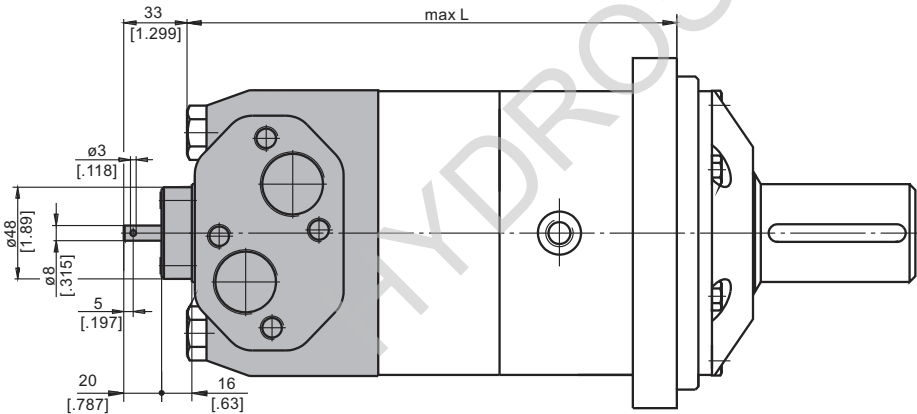

MAX. PERMISSIBLE SHAFT SEAL PRESSURE for MV motors

Max. return pressure without drain line or
max. pressure in the drain line

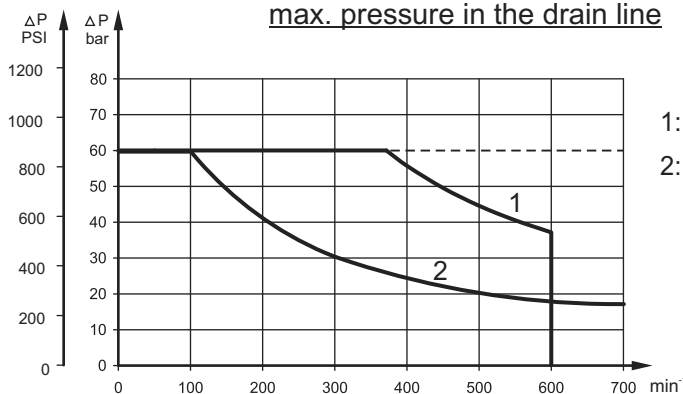

- 1: Drawing for High Pressure Seal ("U" Seal)
- 2: Drawing for Standard Shaft Seal

— - continuous operations
 - - - - intermittent operations



SHAFT EXTENSIONS

C - $\varnothing 50$ straight, Parallel key A14x9x70 DIN 6885

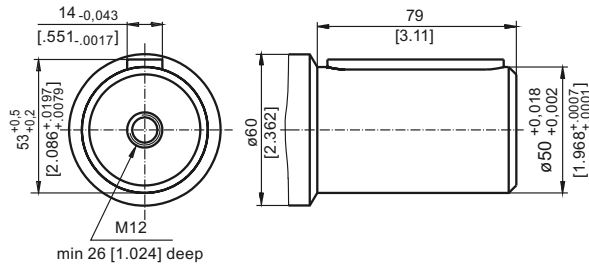

CO - $\varnothing 2\frac{1}{4}$ " [57,15] straight, Parallel key $\frac{1}{2}$ " x $\frac{1}{2}$ " x $2\frac{1}{4}$ " BS46

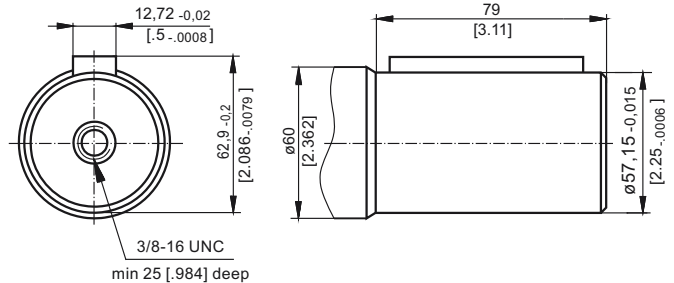

SH - $\varnothing 2\frac{1}{8}$ " splined, 16 DP 8/16 ANS B92.1-1976

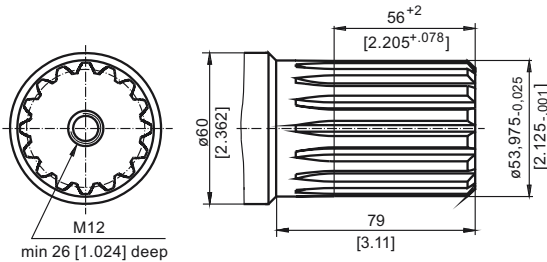

K - tapered 1:10, Parallel key B16x10x32 DIN 6885

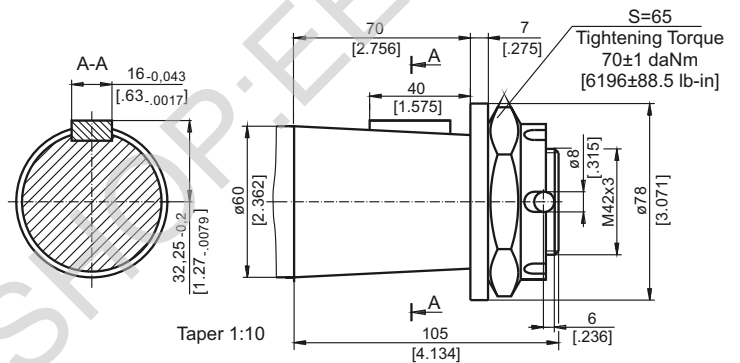

ORDER CODE

	1	2	3	4	5	6
MV						

Pos. 1 - Mounting Flange

omit - Square mount, four holes

C - SAE C mount

W - Wheel mount

S - Short mount

V - Very short mount

Pos. 2 - Displacement code

315 - 314,5 cm³/rev [19.18 in³/rev]

400 - 400,9 cm³/rev [24.45 in³/rev]

500 - 499,6 cm³/rev [30.48 in³/rev]

630 - 629,1 cm³/rev [38.38 in³/rev]

800 - 801,8 cm³/rev [48.91 in³/rev]

Pos. 3 - Shaft extensions*

omit - for **S** and **V** mounting flange

C - $\varnothing 50$ straight, Parallel key A14x9x70 DIN6885

CO - $\varnothing 2\frac{1}{4}$ " straight, Parallel key $\frac{1}{2}$ " x $\frac{1}{2}$ " x $2\frac{1}{4}$ " BS46

SH - $\varnothing 2\frac{1}{8}$ " splined, ANS B92.1-1976

K - $\varnothing 60$ tapered 1:10, Parallel key B16x10x32 DIN6885

Pos. 4 - Shaft Seal Version (see page 49)

omit - Low pressure shaft seal

U - High pressure shaft seal

Pos. 5 - Special Features (see page 51)

Pos. 6 - Design Series

omit - Factory specified

NOTES:

* The permissible output torque for shafts must not be exceeded!

The hydraulic motors are mangan- phosphatized as standard.