

hydraulic piston pumps for trucks

XP
Series

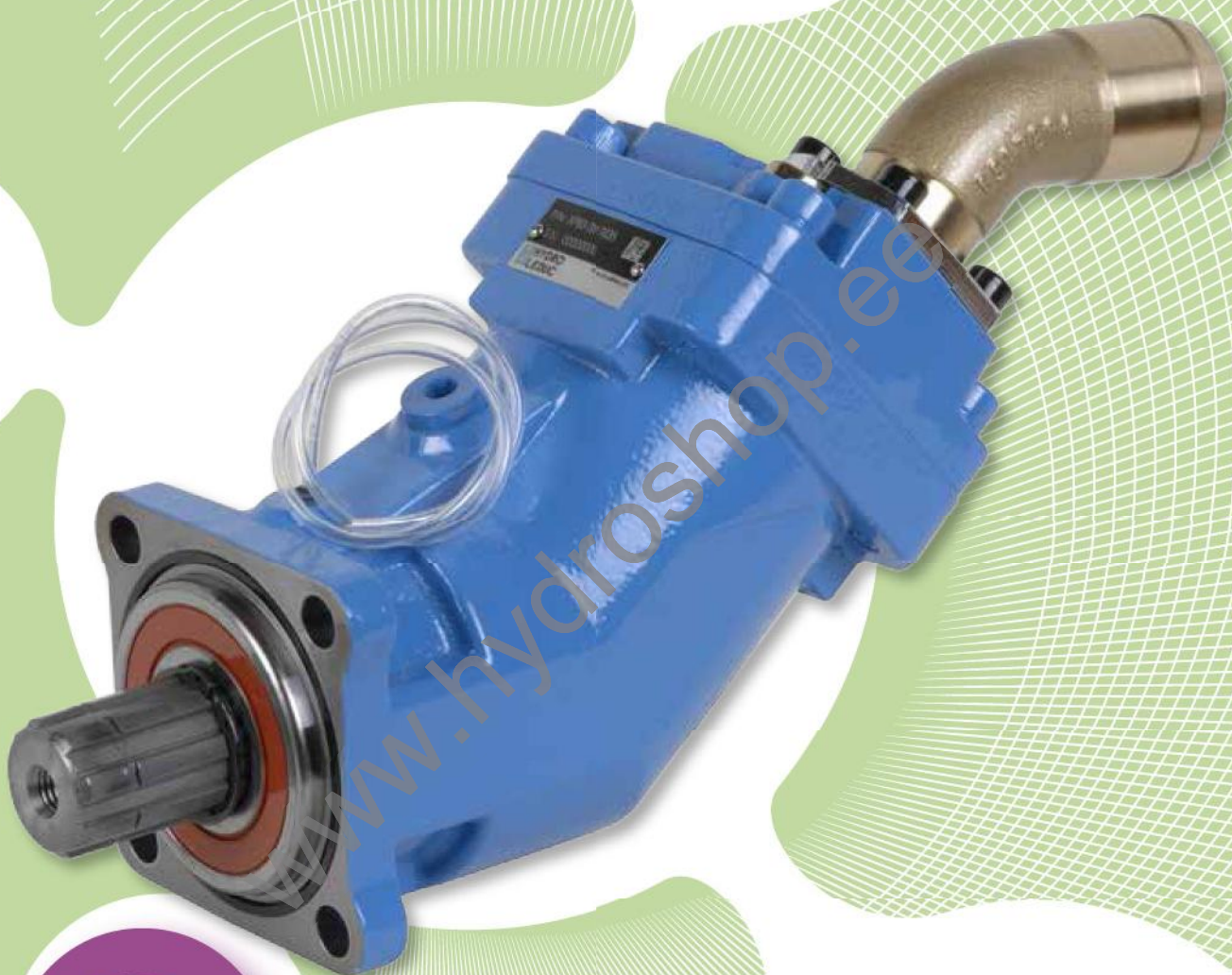

**HYDRO
LEDUC**
make it simple



■ Design of XP series pumps	1
■ Range and characteristics	2
■ Performance	3
■ Dimensions	4
■ Changing direction of rotation	5
■ Accessories	6
■ Shaft sealing	7
■ Installation and start-up recommendations	8
■ The complete LEDUC product range	9

A complete range dedicated to truck hydraulics

PA-PAC-X Series

A range of axial piston pumps: single flow models from 12 to 144 cc/rev, twin flow models from 2 x 25 to 2 x 75 cc/rev.
Literature on request or on our website : www.hydroleduc.com



XA Series

The SAE version of XP bent axis pumps.
Literature on request or on our website : www.hydroleduc.com



TXV Series



Variable displacement pumps with flow and pressure regulation (Load Sensing).
Literature on request or on our website : www.hydroleduc.com



HYDRO LEDUC
Head Office & Factory
BP 9
F-54122 AZERAILLES (FRANCE)
Tél. +33 (0)3 83 76 77 40
Fax +33 (0)3 83 75 21 58



The XP range pumps are designed for the most severe working conditions in terms of :

- space available ;
- drive speed of the pump ;
- power required.

To meet such performance criteria, HYDRO LEDUC opted for the "bent axis" concept, and optimized the pump design in several ways :

- 7 pistons ;
- original idea for plate – barrel synchronisation ;
- change of direction of rotation by simply changing a fitting ;
- use of materials with high mechanical resistance ;
- reinforced sealing.

The XP pumps therefore offer exceptional performance :

- greatly reduced noise levels ;
- high rotating speeds ;
- simple to use ;
- long service life.

The exceptional compacity of the XP pumps, together with their technology, means they can be installed in the most challenging size envelopes and where rotating speed – due to the PTO ratio for example – is high.



Range and characteristics XP series pumps

10 models

- from 12 to 130 cc
- 350 bar continuous working pressure
- 400 bar peak pressure
- maximum speed from 1750 to 3150 rpm

Minimum size envelope
High rotating speeds
High output pressure



2



Pump reference	Displac. cc	Maximum continuous pressure bar	Maximum intermittent peak pressure ≤ 5 seconds bar	Maximum rotating speed at absolute pressure 1 bar with pipe 2" rpm	Maximum torque absorbed at 350 bar Nm	Weight		Overhang torque	
						without inlet fitting kg	with inlet fitting kg	without inlet fitting N.m	with inlet fitting N.m
XP12 0518510	12	350	400	3150	71	9.2	9.65	8.74	9.17
XP18 0517655	18	350	400	2900	107	9.25	9.7	8.79	9.21
XP25 0517665	25	350	400	2650	148	9.3	9.75	8.84	9.26
XP32 0517640	32	350	400	2700	190	11.1	11.55	11.1	11.55
XP41 0517650	41	350	400	2500	243	11.15	11.6	11.15	11.6
XP50 0517625	50.3	350	400	2500	292	11.2	11.65	11.76	12.23
XP63 0517635	63	350	400	2300	362	11.25	11.7	11.81	12.28
XP80 0517610	80.4	350	400	2150	460	14.84	15.3	17.82	18.36
XP108 0517620	108.3	350	400	1950	619	14.95	15.4	17.94	18.48
XP130 0517795	129.8	350	400	1750	730	15.35	15.8	18.73	19.28

Performance XP series pumps

Torque absorbed as a function of pump output pressure

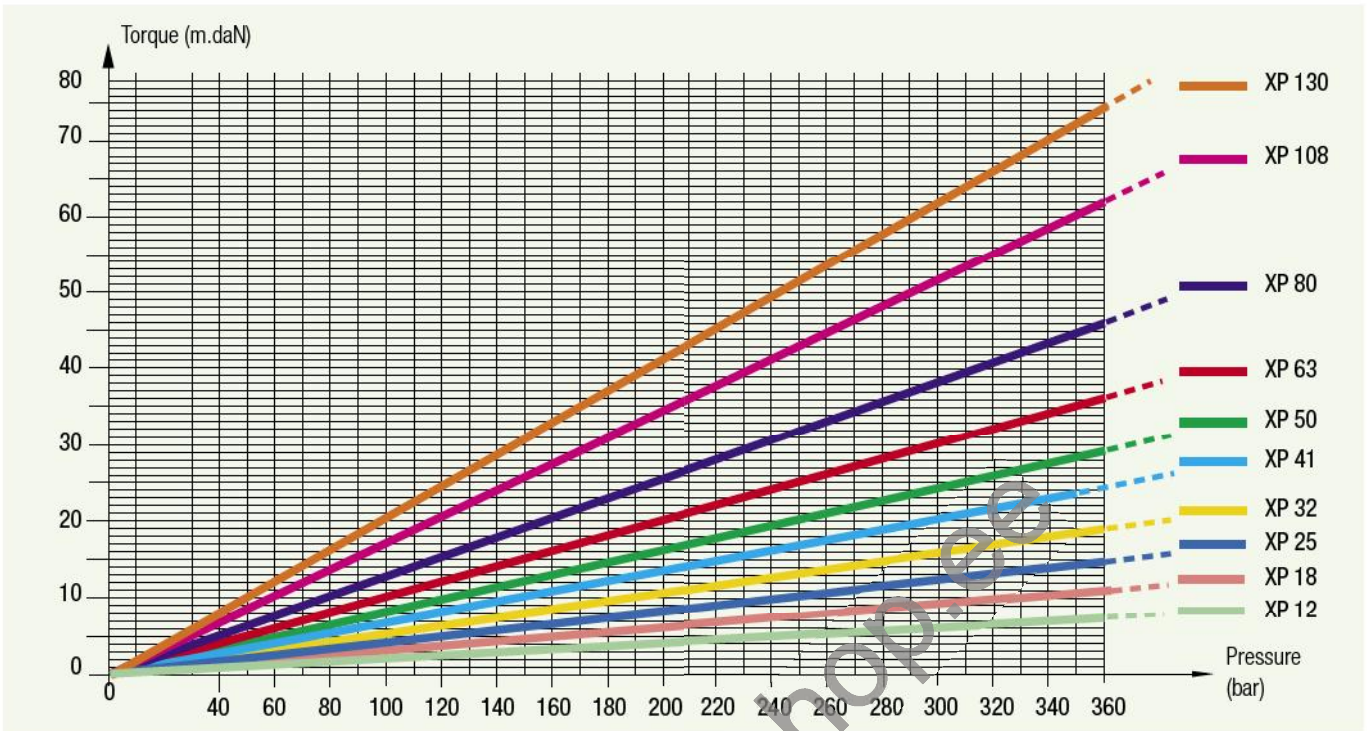

Flow



Volumetric efficiency

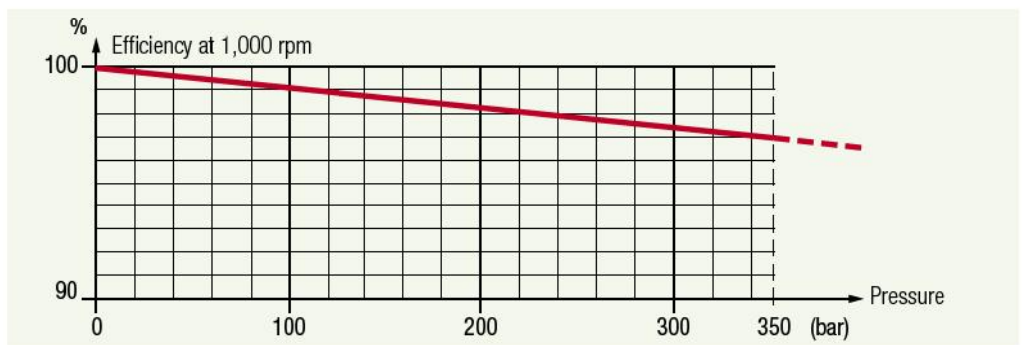

These graphs are the results of test-work done in the HL R&D laboratory, on a specific test bench, with an ISO 46 fluid at 77°F/25°C (100 cSt), the pump is fitted with an 2" HL inlet fitting, hosing is 13 feet (4 metres) long, and tank situated slightly above pump.

Dimensions XP series pumps

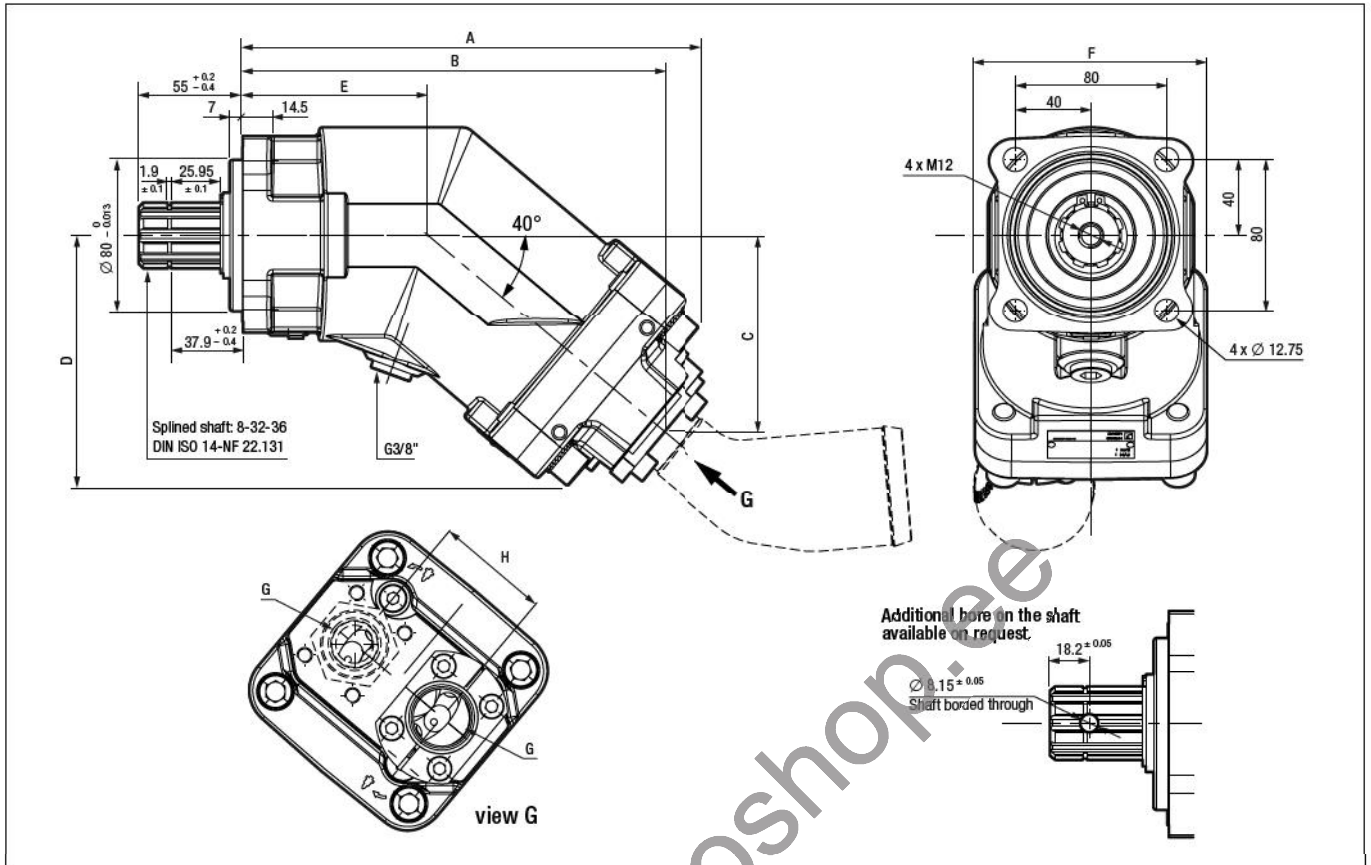

4

Pump reference	A	B	C	D	E	F	G	H
XP12 0518510	196.7	177.8	77.1	103.9	85.7	108	3/4"	54
XP18 0517655	196.7	177.8	77.1	103.9	85.7	108	3/4"	54
XP25 0517665	196.7	177.8	77.1	103.9	85.7	108	3/4"	54
XP32 0517640	202.8	184	82.3	109.1	85.7	108	3/4"	54
XP41 0517650	202.8	184	82.3	109.1	85.7	108	3/4"	54
XP50 0517625	214.4	195.6	92	118.9	85.7	108	3/4"	54
XP63 0517635	214.4	195.6	92	118.9	85.7	108	3/4"	54
XP80 0517610	241.7	220.9	103.5	133.3	97.4	123	1"	60
XP108 0517620	241.7	222.5	104.8	133.3	97.4	123	1"	60
XP130 0517795	244	224.8	106.7	135.2	97.4	123	1"	60

Inlet fittings for XP pumps

All XP pumps are supplied with their inlet fitting. Please specify required fitting from the choice below when ordering.

45° elbow fittings

Reference	∅ hose	∅ A	E	F
0517894	1 1/2"	39.1	91.7	46.7
0517896	42	43	91.7	46.7
0517897	1 3/4"	46	91.7	46.7
0517893	2"	51.8	108.4	54.4
0517892	2 1/2"	64.5	125.2	62.2

90° elbow fittings

Reference	∅ hose	∅ A	E	F
0517947	1 1/2"	39.1	58.6	79.5
0517946	2"	51.8	64.9	80.2
0517945	2 1/2"	64.5	71.3	87.5

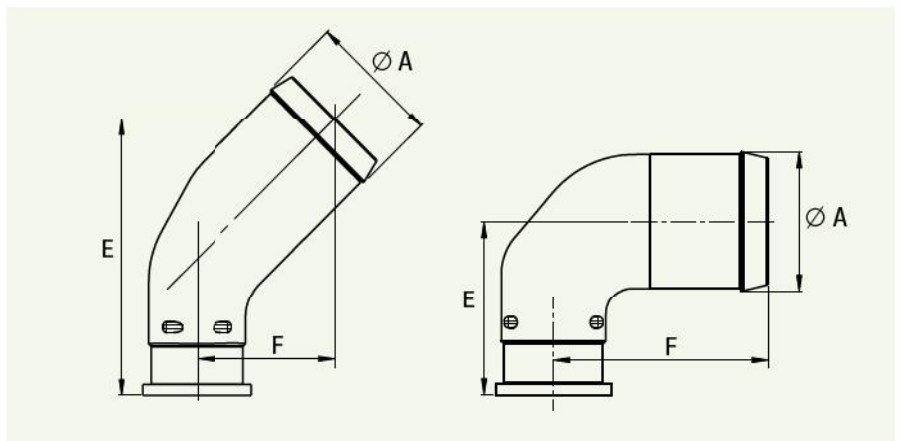

Direction of rotation XP series pumps

How to change the direction of rotation of the pump

All LEDUC XP pumps are supplied for Clockwise rotation (CW) unless otherwise specified on each purchase order.

To check in which direction the pump should rotate on your installation:

- check the direction of rotation of the PTO;
- if the PTO turns clockwise, the pump must rotate counter-clockwise, and vice versa.

To change the direction of rotation of your XP pump:

- remove the inlet fitting (2) and the 2 parts of the split flange (3).
- remove the rotation setting screw (1).
- remove the plug (6).
- put the rotation setting screw (1) where the plug (6) was, and the plug (6) where the rotation setting screw (1) was.
- put seal (5) on the inlet fitting, then the inlet fitting on the side where the plug (6) is, and fix with the split flange. Tighten with the screws (4).

Important note:

Do not rotate pump shaft at all until the rotation setting screw (1) is in place. The rotation setting screw is always on the output (pressure) side.

The various parts should be tightened to the following torque values :

Tightening torque of rotation setting screw (1) in m.daN	4
Tightening torque of fixation screws (4) in m.daN	2.5
Tightening torque of plug (6) in m.daN	2.5

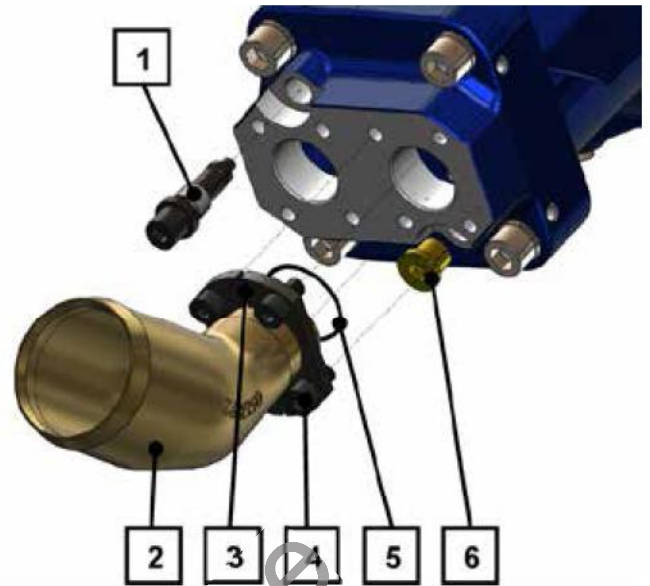

Pump CCW

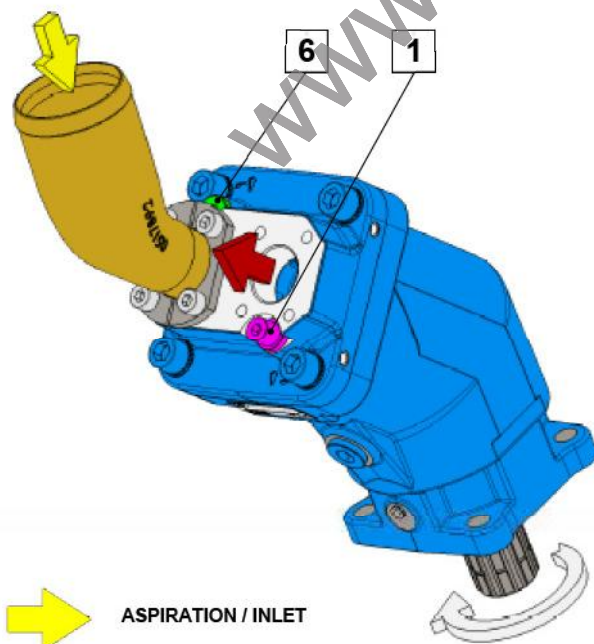

Pump CW

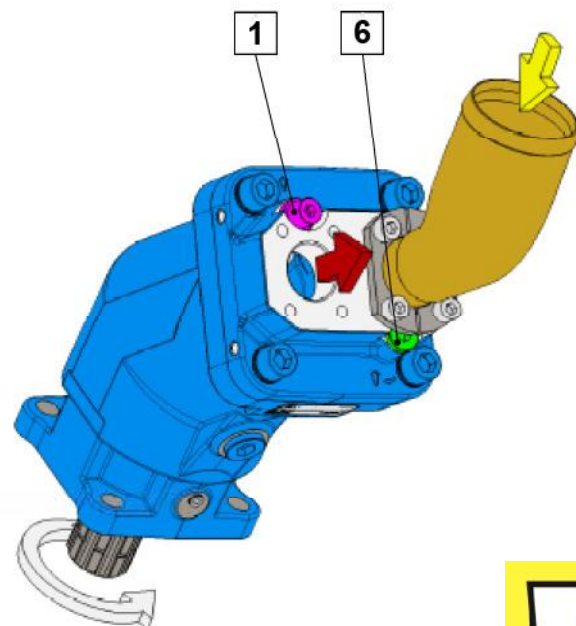

By-pass valve for XP pumps

For XP pump applications where the pump is driven by a continuous running PTO (PTO which cannot be disengaged), HYDRO LEDUC offers a by-pass valve which is fitted onto the back of the pump. This solution allows the continuous running of the pump :

- without creating problems of fluid overheating ;
- without affecting pump service life ;
- with no modifications necessary to the hydraulic equipment on the truck.

How does it work ?

The by-pass valve is a 12 or 24 Volt solenoid valve. When not activated, it enables pump output to link up to pump inlet. When it is activated, the pump operates normally (output flow).

Leduc part number	12 Volt	24 Volt
XP12 to XP63	BP63 0521180	BP63 0517931
XP80 to XP130	BP80 0522235	BP80 0522140

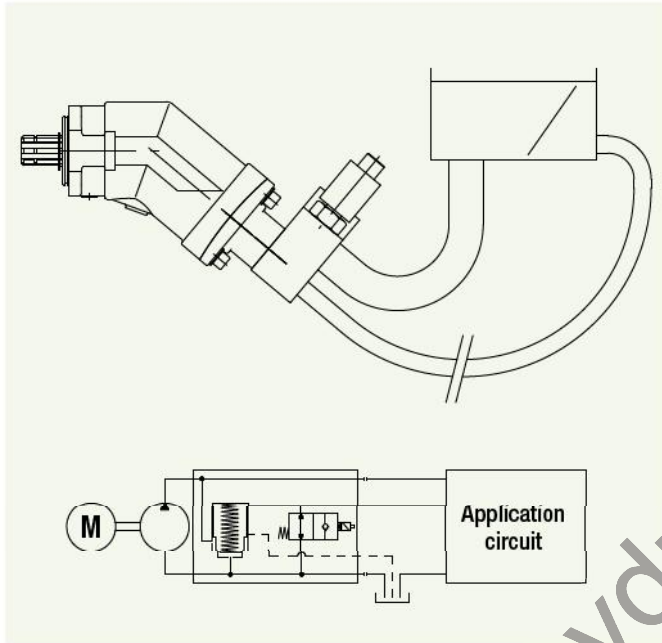

Overhang torque of XP pumps fitted with by-pass valves

Pump model	Weight		Overhang torque	
	without inlet fitting kg	with inlet fitting 2" kg	without inlet fitting N.m	with inlet fitting 2" N.m
XP12	12.8	13.25	16.32	16.90
XP18	12.85	13.3	16.39	16.96
XP25	12.9	13.35	16.44	17.02
XP32	14.7	15.15	18.98	19.56
XP41	14.75	15.2	19.04	19.62
XP50	14.8	15.25	20.05	20.67
XP63	14.85	15.3	20.12	20.73
XP80	18.45	18.9	27.16	27.82
XP108	18.55	19	27.31	27.97
XP130	18.95	19.4	28.16	28.93

For some applications, we recommend using an external drain.

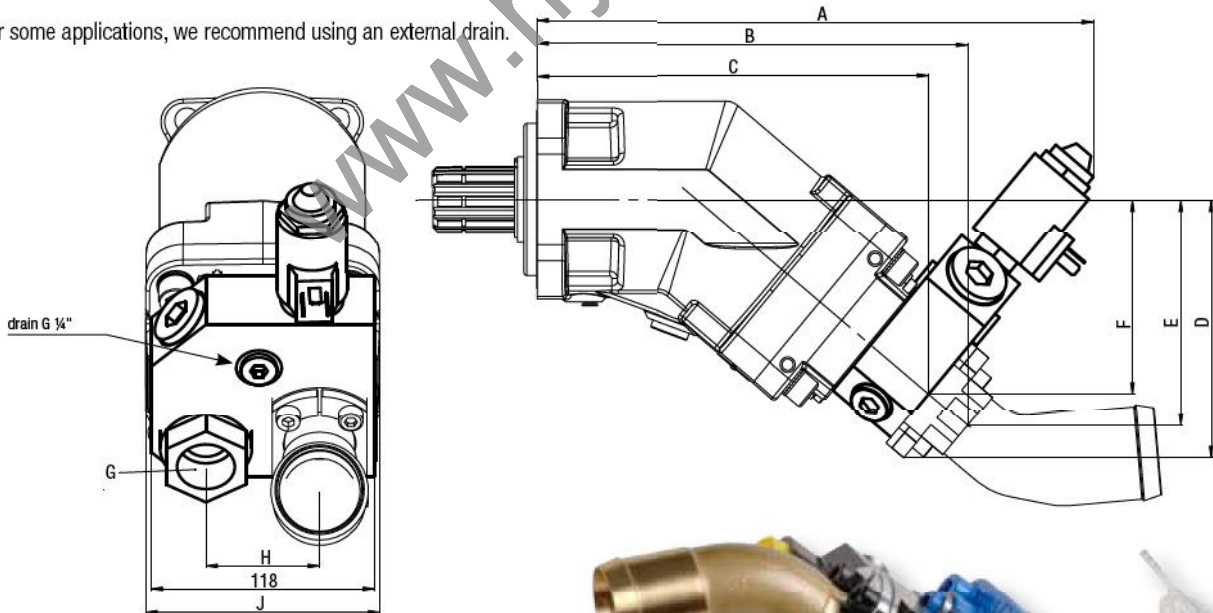

Dimensions including by-pass valve

Pump model	A	B	C	D	E	F	G	H	J
XP 12 / 18 / 25	289.35	223.04	202.19	132.20	114.72	97.58	3/4"	54	108
XP 32 / 41	295.5	229	208.3	137.3	120.1	102.7	3/4"	54	108
XP 50 / 63	307.1	240.4	220	147.1	129.7	112.5	3/4"	54	108
XP 80 / 108	334	269	246.7	157.8	143.9	124.8	1"	60	123
XP 130	336.3	271.3	249	159.7	145.8	126.7	1"	60	123.5



LEDUC pumps destined for truck hydraulics (XP, PA, PAC and TXV series) are all fitted with reinforced sealing comprising :

- two radial seals : an external seal adapted to the needs of PTOs and gear-boxes; and an internal seal adapted to the needs of hydraulic performance;
- an original protection of the pump shaft seals. This is a flexible transparent tube which avoids any entry of contaminants between the two seals, and guarantees high pressure water jet cleaning of vehicle will not damage the sealing area. It also allows air vent of the chamber between the two seals.



Examples of tube attachment

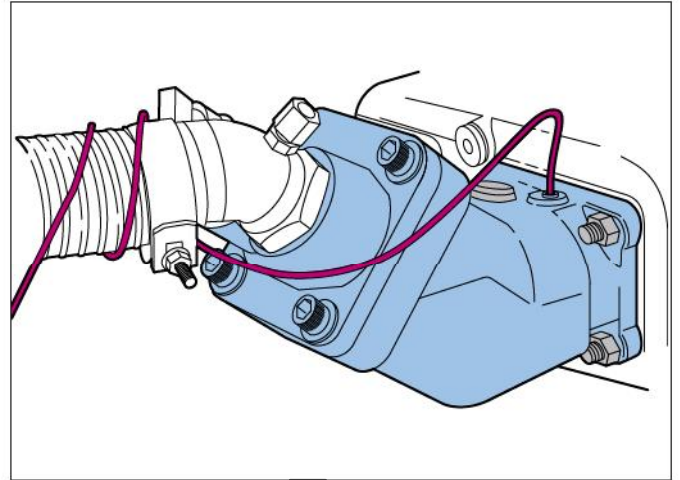

✓ Recommendations for attaching the protective tube :

- make a siphon with the tube so as to avoid any introduction of :
- dirt from road;
- water or damp from high pressure washing of vehicle;
- put the end of the tube downwards, or in a place sheltered from any projections;
- fix the tube in place using a collar/clip.

✗ Avoid :

- attaching the tube to any parts which may move, this could lead to it being damaged or torn off;
- any pinching or folds in the tube when fixing it in place;
- any obturation of the end of the tube.



HYDRO LEDUC stresses that on non-sealed PTO installations it is the hydraulic pump which ensures the sealing of the vehicle gearbox.

This is why HYDRO LEDUC offers tried and tested solutions approved by vehicle manufacturers.

Note in particular the pump – PTO sealing via a frontal square section ring seal ensuring metal to metal contact between pump and PTO. Do not use paper gasket.



www.hydroshop.ee



Make sure your pump lives a long happy life !

■ The tank :

Generally, hydraulic pumps much prefer a tank above the pump. Leduc pumps can also operate with oil level beneath the pump, for further information on such installations, please contact our Technical Department. Correct inlet conditions are between 0.8 to 2 bar absolute pressure.

The tank should preferably have a separation between inlet side and return. This avoids fluid emulsion and the introduction of air into the hydraulic circuit. Ensure also that the suction is not from the very bottom of the tank, so as to protect the pump from any deposits (particles).

■ Hosing :

Should be dimensioned to ensure flow between 0.5 and 0.8 m/second. Choose as direct a supply line as possible, avoiding sharp bends.

■ Filtration :

HYDRO LEDUC recommends using a very clean tank, filtered during filling and with filter on air vent.

The pump supply line must be cleaned (decontaminated) and the return line should be filtered as follows :

- for relatively simple circuits (e.g. tippers) : use a 20 micron filter on pump return line.
- for more complex circuits (e.g. cranes) :

Ideal solution :

- high pressure filter between the pump and the crane hydraulic circuit ;
- 10 to 20 micron filter ;
- clogging indicato.

■ The fluid :

Use a mineral hydraulic oil with viscosity between 10 and 400 cSt. It is in this viscosity range that the pumps keep their volumetric characteristics. If you wish to use other fluids, please consult our Technical Department. Maximum temperature of fluid in the pump should not exceed 100°C.

■ Drive and assembly recommendations :

For PTO mount applications, be careful to respect the tightening recommendations in terms of pump onto PTO and PTO onto vehicle gearbox. XP pumps are not designed to withstand any axial load on the pump shaft. Check your installation conforms to this requirement.

■ Preparation of the pump :

For XP pumps, check the direction of rotation needed, and change it if necessary. See instructions on page 5.

Before start-up, the pumps should be filled with oil. This is essential for XP-pumps.

■ Start-up :

- open the supply valve if there is one ;
- check the valve is in "back to tank" position ;
- partially unscrew the output fitting ;
- start up at low speed, or by successive starts/stops ;
- retighten the output connector as soon as air bubbles have disappeared ;
- let the pump run for one to two minutes, and check that the flow is well established ;
- check the pump is running correctly, with no vibrations nor abnormal noise ;
- after several hours of operation, check the tightening torque of the pump fixture to PTO.

■ Maintenance :

Some regular checks are necessary, namely :

- tightening of pump to PTO ;
- cleanliness of fluid ;
- state of filter ;



if you notice traces of oil in the plastic tube, it is essential to check the sealing between PTO and pump.



other product lines

hydraulic motors

Fixed displacement bent-axis piston motors. Models from 5 to 180 cc. Available both in ISO and SAE versions.

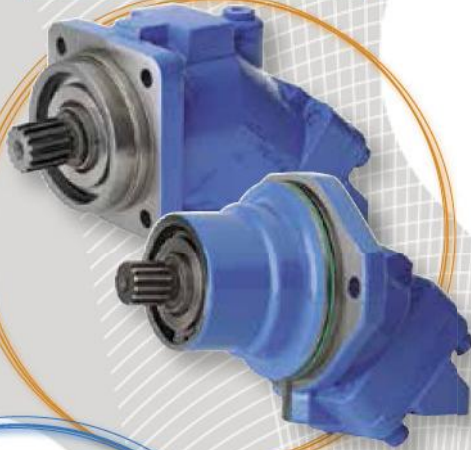

mobile and industrial pumps

Fixed displacement pumps, the W series, and variable displacement pumps, the DELTA series. High pressure capabilities within minimal size.

W series: flanges to ISO 3019/2, shafts to DIN 5480.
DELTA series: SAE shafts and flanges.



hydro-pneumatic

accumulators

Bladder, diaphragm accumulators.
Spherical and cylindrical accumulators.
Volume capacities from 20 cc to 50 liters.
Pressures up to 500 bar.
Accessories for use with hydraulic accumulators.

TXV

XP

PA
PAC
PAD

piston pumps for trucks

HYDRO LEDUC offers 3 types of piston pumps perfectly suited to all truck and PTO-mount applications. Fixed and variable displacement from 12 to 150 cc.

micro-hydraulics

This is a field of exceptional HYDRO LEDUC know-how:

- axial and radial piston pumps, of fixed and variable displacement,
- axial piston micro-hydraulic motors,
- micro-hydraulic units incorporating pump, electric motors, valving, controls, etc.

To users of hydraulic components which have to be housed in extremely small spaces, HYDRO LEDUC offers complete, original and reliable solutions for even the most difficult environments.



we are passionate about hydraulics...

HYDRO LEDUC

A dedicated R&D team means HYDRO LEDUC is able to adapt or create products to meet specific customer requirements. Working in close cooperation with the decision-making teams of its customers, HYDRO LEDUC optimizes proposals based on the specifications submitted.

a passion for hydraulics

HYDRO LEDUC

Head office and Factory
BP 9 - F-54122 AZERAILLES (FRANCE)
Tél. +33 (0)3 83 76 77 40 - Fax +33 (0)3 83 75 21 58

HYDRO LEDUC GmbH

Haselwarder Str. 5
D-77746 SCHUTTERWALD (GERMANY)
Tel. +49 (0) 781-9482590 - Fax +49 (0) 781-9482592

HYDRO LEDUC AB

Göteborgsvägen 74
SE-433 02 Sävedalen (SWEDEN)
Tel. (+46) 070 26 17 770

HYDRO LEDUC N.A., Inc.

19416 Park Row - Suite 170
HOUSTON, TEXAS 77084 (USA)
Tel. +1 281 679 9654 - Fax +1 832 321 3553

Complete catalogues available at:
www.hydroleduc.com



HYDRO LEDUC

SAS with capital of 4 065 000 euros

Siret 319 027 421 00019

RC Nancy B 319 027 421

mail@hydroleduc.com

 **HYDRO
LEDUC**
make it simple