

**Vickers®** PVH Piston Pumps

57-141 cc<sup>3</sup>  
(3.5-8.6 in<sup>3</sup>)

H-Series  
Industrial Variable  
Displacement

H-Series  
Mobile Variable  
Displacement

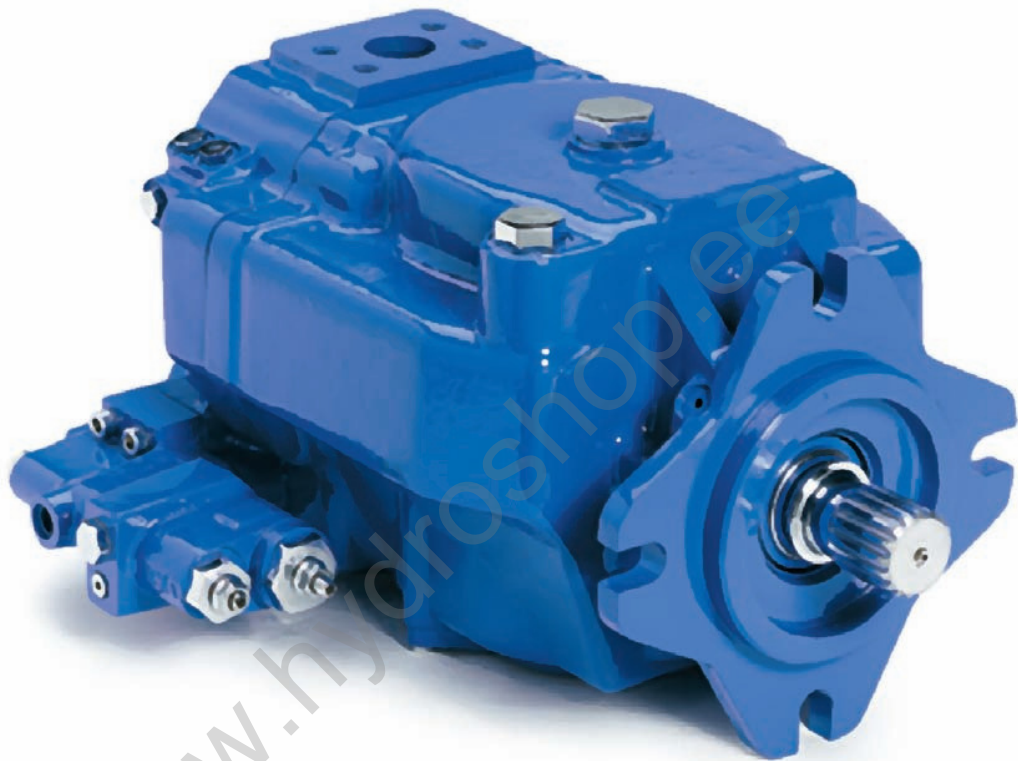

# Table of Contents

## H Series Variable Displacement Piston Pumps

<b>Principles of Operation</b> .....	<b>3</b>
<b>Hydraulic System Design Calculations</b> .....	<b>4</b>
<b>Introduction</b> .....	<b>5</b>
<b>Model Codes</b> .....	<b>6</b>
<b>Performance Data</b>	
Rated Characteristics .....	8
Performance Curves .....	9
Response Data .....	14
Sound Levels .....	14
<b>Control Options</b>	
Pressure Compensator .....	15
Load Sensing and Pressure Compensator .....	15
Pressure and Torque Limiter Control .....	16
Pressure and Torque Limiting Plus Load Sensing .....	17
Pressure Compensator without Load Sensing Option .....	18
Remotely Controllable Pressure Compensator with Load Sensing Option .....	19
Electronic Displacement Control .....	20
<b>Input Shaft Selection Data</b> .....	<b>22</b>
<b>Input Shaft Dimensions</b> .....	<b>23</b>
<b>Installation Dimensions</b>	
Basic Pumps (Non-thru-drive) .....	24
Adjustable Maximum Volume Stop .....	28
Thru-drive Pumps .....	29
ISO Pump Mounting Flange .....	32
Combination 2-Bolt/4-Bolt SAE Pump Mounting Flange .....	32
Rear Cover for Thru-drive Pump .....	32

# Principles of Operation

In axial piston pumps, the pistons reciprocate parallel to the axis of rotation of the cylinder block. The simplest type of axial piston pump is the swash plate in-line design.

The cylinder block in this pump is turned by the drive shaft. Pistons fitted to bores in the cylinder block are connected through piston shoes and a shoe plate, so that the shoes bear against an angled swash plate.

As the block turns, the piston shoes follow the swash plate, causing the pistons to reciprocate. The ports are arranged in the valve plate so that the pistons pass the inlet as they are pulled out and pass the outlet as they are forced back in.

The displacement of axial piston pumps is determined by the size and number of pistons, as well as the stroke length which is determined by the angle of the swash plate.

In variable displacement models of the in-line pump, the swash plate is installed in a movable yoke.

"Pivoting" the yoke on pintles changes the swash plate angle to increase or decrease the piston stroke.

## Piston Pump Operation

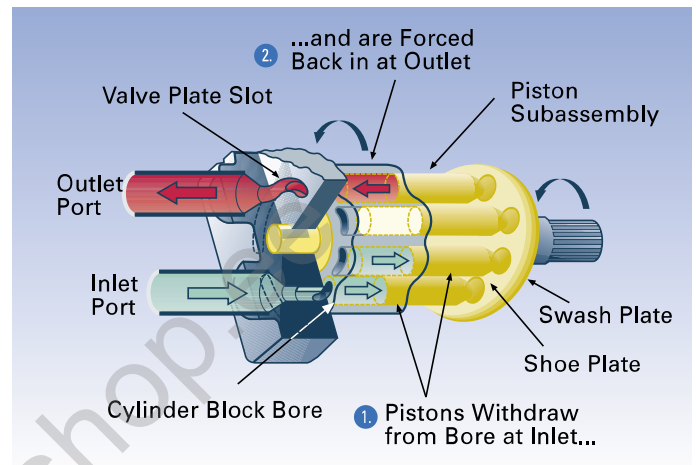

www.hydroshop

# Hydraulic System Design Calculations

## Basic Formulas

### Output Flow (Q)

$$lpm = \frac{cm^3/r \times rpm}{1000} \quad gpm = \frac{in^3/r \times rpm}{231}$$

### Input Power (P)

$$kW = \frac{l/min \times bar}{600} \quad hp = \frac{gpm \times psi}{1714}$$

### Shaft Torque (M)

$$N-m = \frac{bar \times cm^3/r}{62.8} \quad lb-in = \frac{psi \times in^3/r}{6.28}$$

### Shaft Speed (n)

$$rpm = \frac{1000 \times l/min}{cm^3/r} \quad RPM = \frac{231 \times gpm}{in^3/r}$$

### Output Power (P)

$$kW = \frac{N-m \times RPM}{9549} \quad hp = \frac{lb-in \times rpm}{63,025}$$

### Volumetric Displacement

$$cm^3/r = \frac{lpm \times 1000}{rpm} \quad in^3/r = \frac{gpm \times 231}{rpm}$$

## Basic Formulas

## Efficiencies

$$\text{Volumetric } N_v = \frac{gpm \text{ actual}}{gpm \text{ theoretical}}$$

$$\text{Mechanical } N_m = \frac{lb-in \text{ actual}}{lb-in \text{ theoretical}}$$

$$\text{Total } N_t = N_v \times N_m$$

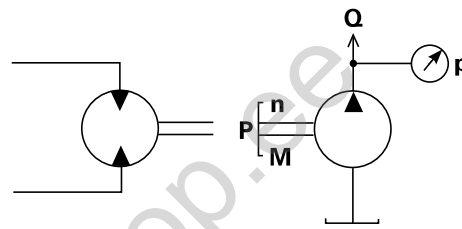

## Commonly Used Conversions

To Convert	Into	Multiply by
bar	psi	14.5
cm <sup>3</sup>	in <sup>3</sup>	0.06102
°C	°F	(°C × 1.8) + 32
gallons (US)	liters	3.785
kg	lbs	2.205
kgf/cm <sup>2</sup>	psi	14.2
kW	hp	1.341
liters	US Gallons	0.2642
mm	inches	0.03937

# Introduction

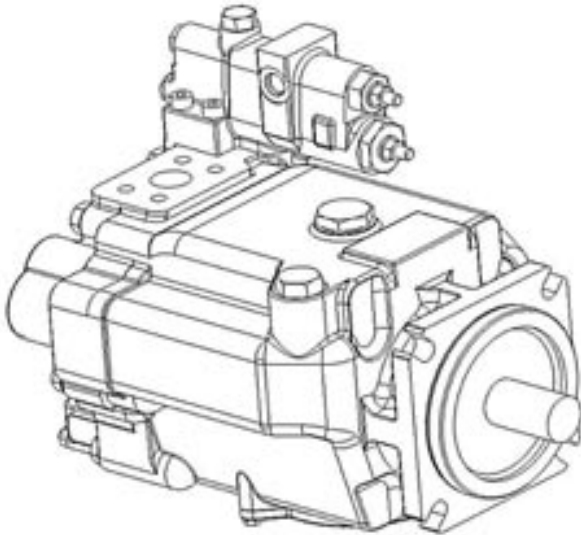

Eaton's Vickers® PVH high flow, high performance pumps are a family of variable displacement, inline piston units that incorporate the proven design, quality manufacturing techniques and operating features of other Vickers piston pumps, but in a smaller, lighter package.

The PVH series has been specially designed to meet the 250 bar (3625 psi) continuous duty performance requirements of new generation equipment designs.

These are efficient, reliable pumps, with a selection of optional controls for maximum operational flexibility. Designed specifically for strenuous application, they provide the productivity gains and controllability improvements desired in earth-moving, construction, machine tool, plastics, and all other energy-conscious markets. As with all Eaton products, these pumps have been fully laboratory tested and field proven.

## PVH Series Benefits

- Versatile design includes single pumps, thru-drive arrangements, and a variety of drive shaft and control options that will adapt to any application and provide the most cost effective installation.
- Proven components designed into a heavy duty, compact housing to provide 250 bar (3625 psi) continuous operating performance, and 280 bar (4050 psi) operating performance in a load sensing system. This design assures long life at the higher performance levels required of today's power-dense machinery.
- Compact and lightweight design to reduce the application weight, and provide better access for installation and
- Quiet designs available for noise-sensitive industrial applications, reducing sound levels further to provide a more acceptable environment.
- Designed for maximum efficiency in any type of application. A variety of compensators provide the most effective system control, and the 95%-plus volumetric efficiency means more flow, and more input energy, is directed to the work and not into heat and waste.
- Heavy duty bearings and shafts result in minimum internal deflections and wear, providing for longer life and maximum uptime.

# Model Codes

## PVH Piston Pump

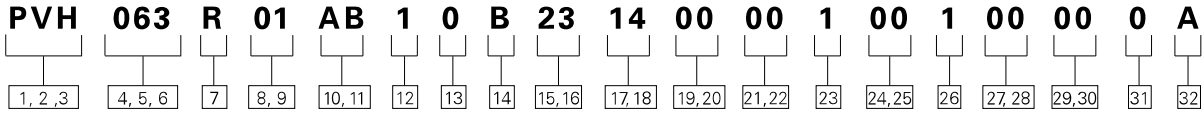

### 1, 2, 3 Pump Series

**PVH** – PVH OC Piston Pump

### 4, 5, 6 Displacement

- 057** – 57.4 cm<sup>3</sup>/r [3.50 in<sup>3</sup>/r]
- 063** – 63.1 cm<sup>3</sup>/r [3.85 in<sup>3</sup>/r]
- 074** – 73.7 cm<sup>3</sup>/r [4.50 in<sup>3</sup>/r]
- 081** – 81.0 cm<sup>3</sup>/r [4.94 in<sup>3</sup>/r]
- 098** – 98.3 cm<sup>3</sup>/r [6.00 in<sup>3</sup>/r]
- 106** – 106.5 cm<sup>3</sup>/r [6.50 in<sup>3</sup>/r]
- 131** – 131.1 cm<sup>3</sup>/r [8.00 in<sup>3</sup>/r]
- 141** – 141.0 cm<sup>3</sup>/r [8.60 in<sup>3</sup>/r]

### 7 Rotation

- R** – Right-Hand Rotation (cw)
- L** – Left-Hand Rotation (ccw)

### 8, 9 Front Mounting and Input Shaft

- 01** – 4 Bolt C, 1-1/4 inch Dia. Keyed
- 02** – 4 Bolt C, 14T 12/24 DP Splined
- 03** – 4 Bolt C, 17T 12/24 DP Splined
- 04** – 4 Bolt C, 1-1/2 inch Tapered Shaft & Woodruff Keyway
- 05** – 4 Bolt C, 1-1/4 inch Dia. Tapered Keyed & 3/4-16 UNF-2A Ext Thread
- 08** – 2 Bolt B, 15T 16/32 DP Splined

- 23** – 2 Bolt C, 17T 12/24 DP Splined Shaft
- 24** – 2 Bolt B 19T 24/48 DP Splined
- 30** – 4 Bolt C, 14T 12/24 DP Splined, 78.0 (3.07) Shaft Extension and 54.0 (2.12) Spline Length
- 51** – 2/4 Bolt C, 1-1/4 inch Dia Straight Keyed
- 52** – 2/4 Bolt C, 14T 12/24 DP Splined
- 53** – 2/4 Bolt C, 17T 12/24 DP Splined
- 58** – 2 Bolt B, 15T 16/32 DP Splined
- 60** – 2/4 Bolt C, 14T 12/24 DP Splined, 73.2 (2.88) Shaft Extension and 49.0 (1.93) Spline Length
- 62** – 2 Bolt C, 13T 8/16 DP Splined

### 10, 11 Main Ports Size & Location

- AA** – Side Ports; Suction 2 in. (Code 61) Pressure 1 in. (Code 61)
- AB** – Side Ports; Suction 2 in. (Code 61) - w/ M12 Threads; Pressure 1 in. (Code 61) - w/ M10 Threads

- AE** – Side Ports; Suction 2.5 (Code 61) w/ M12 Threads; Pressure 1.25 (Code 61) w/ M12 Threads
- AF** – Side Ports; Suction 2.5 in. (Code 61) ; Pressure - 1.25 in. (Code 62)
- AG** – Side Ports; Suction - 2.5 in. (Code 61) w/ M12 Threads; Pressure - 1.25 in. (Code 62) w/ M14 Threads
- AH** – Side Ports; Suction - 2.0 in. (Code 61) w/ M12 Threads; Pressure - 1.0 in. (Code 61) w/ M12 Threads
- AJ** – Side Ports; Suction 2.5 in. (Code 61); Pressure 1.0 in. (Code 61)
- AL** – Side Ports; Suction - 2.5 in. (Code 61); Pressure - 1.25 in. (Code 61)

### 12 Drain Ports Size & Location

- 1** – #8 SAE O-Ring Port - Bottom (Top Plugged)
- 2** – #8 SAE O-Ring Port - Top (Bottom Plugged)
- 3** – #10 SAE O-Ring Port - Bottom (Top Plugged)

- 9** – #12 SAE O-Ring Port - Bottom (Top Plugged)
- A** – #12 SAE O-Ring Port - Top (Bottom Plugged)
- B** – M22 x 1.5 Metric O-Ring - Bottom (Top Plugged)
- C** – M22 X 1.5 Metric O-Ring - Top (Bottom Plugged)
- F** – Vertical Mount w/ G 1/2 BSPP - Bottom (Top Plugged)
- G** – Vertical Mount w/ G 1/2 BSPP - Top (Bottom Plugged)

### 13 Diagnostic Pressure Ports

- 0** – No Diagnostic Pressure Ports

### 14 Controller Type\*

- A** – Pressure Compensator
- B** – Pressure And Flow Compensator
- D** – Pressure Compensator w/Torque Sensing
- E** – Pressure And Flow Compensator w/Torque Sensing
- G** – IC Pressure Compensator
- H** – IC Pressure and Flow Compensator
- J** – IC Pressure and Flow

# Model Codes

## PVH Piston Pump

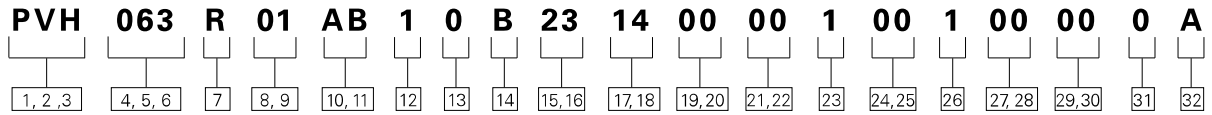

### **15,16 Pressure Comp. Setting**

- 07** – 66-74 bar [957-1073 psi]
- 23** – 226-234 bar [3278-3394 psi]
- 25** – 246-254 bar [3568-3684 psi]

*Other Settings Available by Request*

### **17,18 Flow Compensator Setting**

- 00** – No Flow Comp. Setting
- 14** – 13-15 bar [189-218 psi]
- 24** – 23-25 bar [334-363 psi]
- AA** – Unload Valve Standby 39-41 bar [334-363 psi]

*Other Settings Available by Request*

### **19,20 Torque Setting/ Other Comp.**

- 00** – None
- 04** – 36-44 bar [522-638 psi]
- 14** – 136-144 bar [1973-2089 psi]
- AA** – Unload Valve 186.2-193 bar [2700-2800 psi]  
Reset 157.8-164.6 bar [2288-2387 psi]
- AB** – Unload Valve 203.4-210.2 bar [2950-3050 psi]  
Reset 183-190 bar [2650-2748 psi]

### **23 Maximum Displacement Option**

- 1** – Standard Displacement (As given in code title)
  - 2** – Adjustable Max Displacement (Set at Max)
  - F** – Adjustable Max Displacement (Set at Max) w/ Extended Adjusting Screw
- Other Settings Available by Request.*

### **24,25 Auxiliary (Rear) Mount and Output Shaft**

- 00** – No Auxiliary Mounting Features
- AA** – 2/4 Bolt C, 14T 12/24DP
- AB** – 2/4 Bolt B, 15T 16/32DP
- AC** – 2 Bolt A, 9T
- AY** – 2/4 Bolt B, 13T 16/32DP
- AZ** – 2/4 Bolt C, 17T 12/24DP
- BA** – 2 Bolt A, 11T 16/32DP

### **26 Shaft Seal**

- 1** – Single, OneWay Shaft Seal, Viton®
- 3** – Single, OneWay Shaft Seal, Nitrile
- 5** – Double, TwoWay Shaft Seal, Viton® W/VHO Filter
- 6** – Double, TwoWay Shaft Seal, Nitrile W/VHO Filter

### **27,28 Pump Special Features**

- 00** – No Pump Special Features
- AA** – No Case To Inlet Check Valve
- AE** – Q250 Valve Plate, No Case To Inlet Check Valve
- AF** – Q140 Valve Plate, No Case To Inlet Check Valve
- AP** – Pressure Lube Swashplate
- AR** – Pressure Lube Swashplate, No Case To Inlet Check Valve
- SC** – Q250 Valve Plate, Grooved Saddle Bearings, No Case To Inlet Check Valve
- BH** – Q250 Valve Plate, Pressure Lube Swashplate
- BM** – Q250 Valve Plate, Pressure Lube Swashplate, No Case To Inlet Check Valve
- BR** – Q140 Valve Plate, Grooved Saddle Bearings, No Case To Inlet Check Valve

### **29,30 Paint**

- 00** – No Paint
- 01** – Blue Primer

### **31 Identification**

□



# Performance Data

## PVH057

Delivery and efficiency versus outlet pressure at 1800 r/min

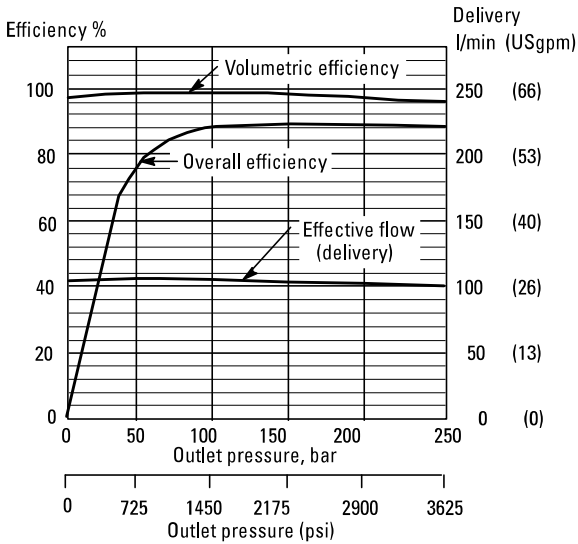

## PVH063

Delivery and efficiency versus outlet pressure at 1800 r/min

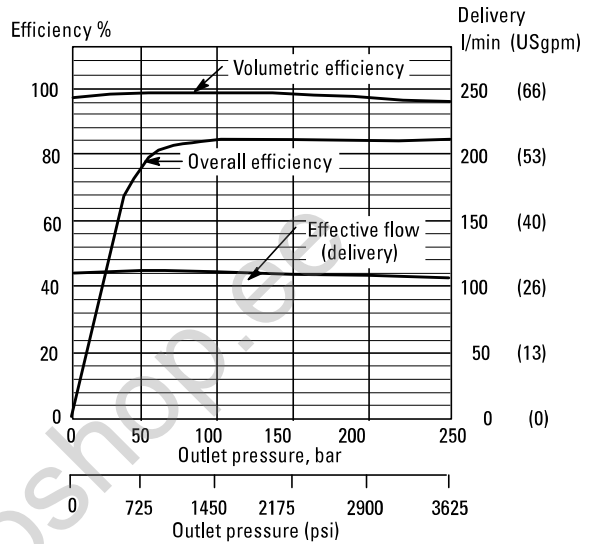

Input torque and power versus outlet pressure at 1800 r/min

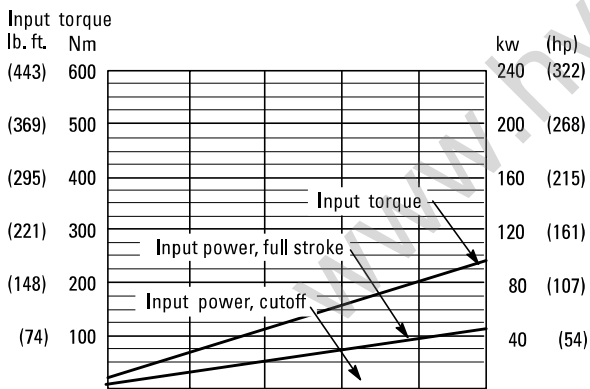

Input torque and power versus outlet pressure at 1800 r/min

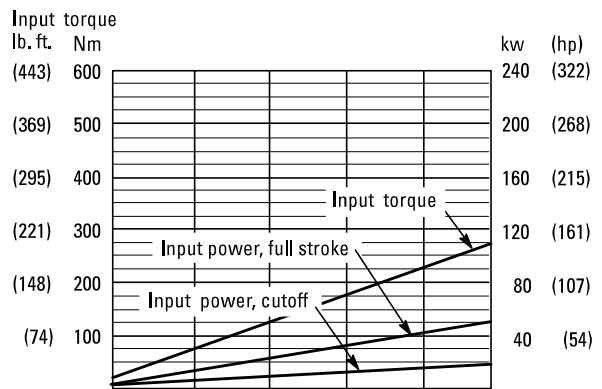

# Performance Data

## PVH074

Delivery and efficiency versus outlet pressure at 1800 r/min

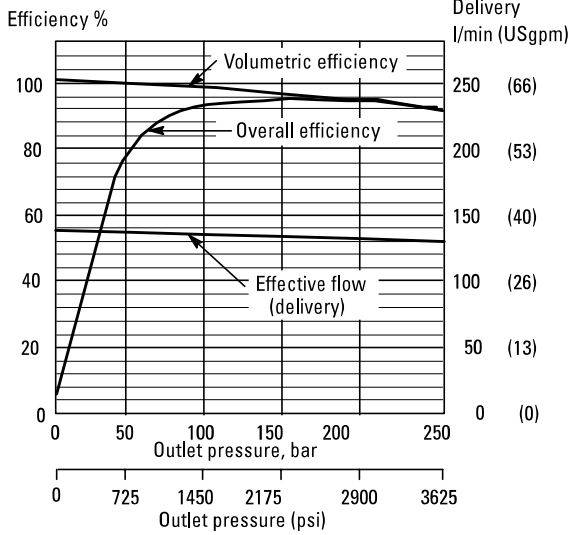

## PVH081

Delivery and efficiency versus outlet pressure at 1800 r/min

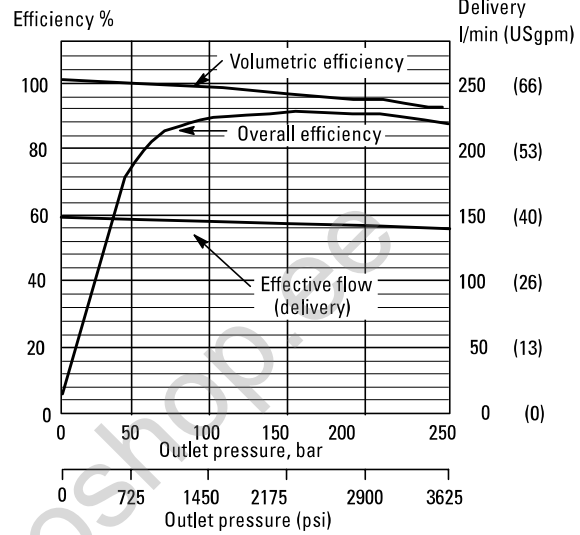

Input torque and power versus outlet pressure at 1800 r/min

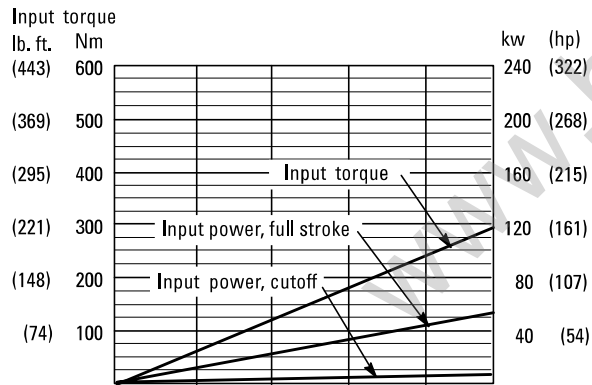

Input torque and power versus outlet pressure at 1800 r/min

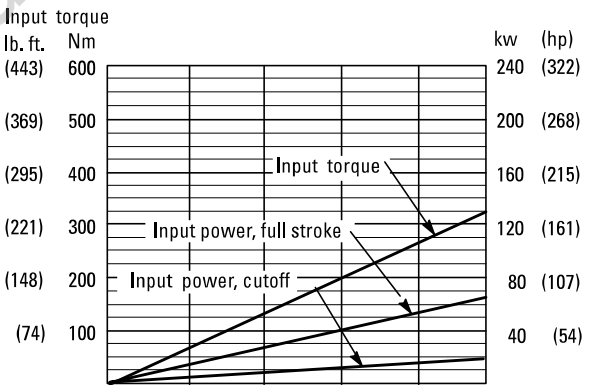

# Performance Data

## PVH098

Delivery and efficiency versus outlet pressure at 1800 r/min

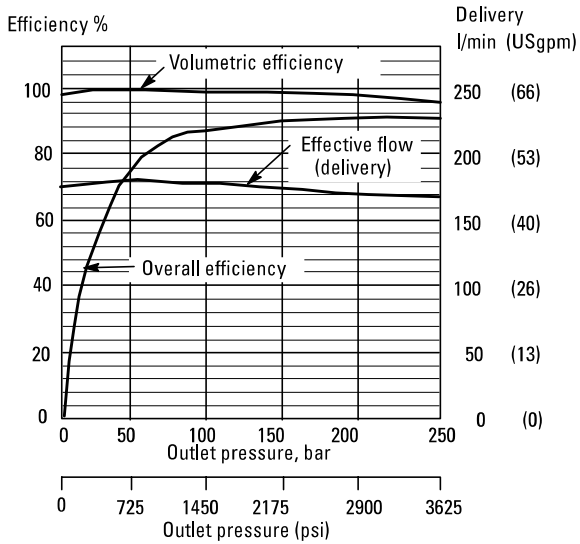

## PVH106

Delivery and efficiency versus outlet pressure at 1800 r/min

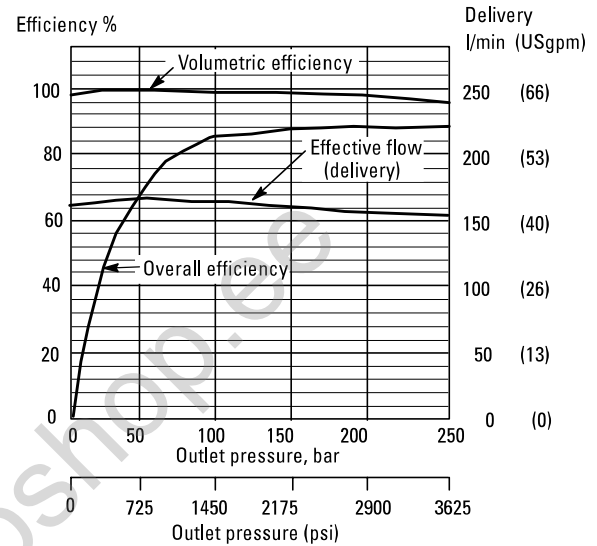

Input torque and power versus outlet pressure at 1800 r/min

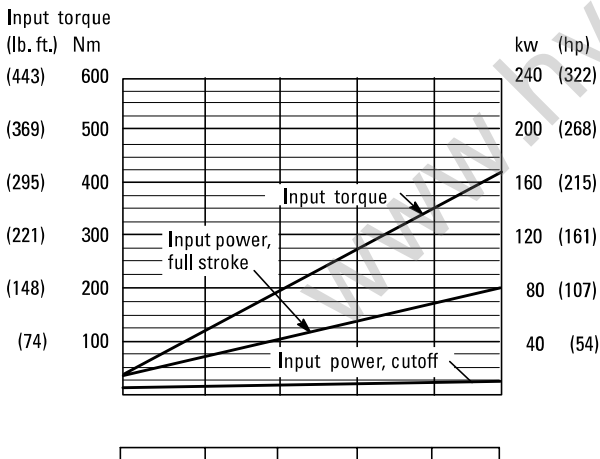

Input torque and power versus outlet pressure at 1800 r/min

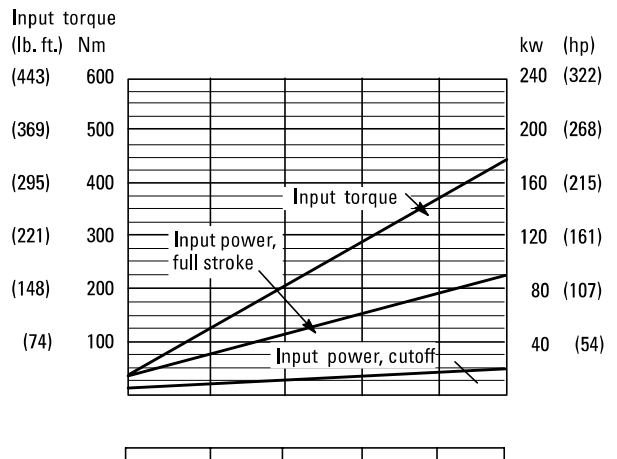

# Performance Data

## PVH131

Delivery and efficiency versus outlet pressure at 1800 r/min

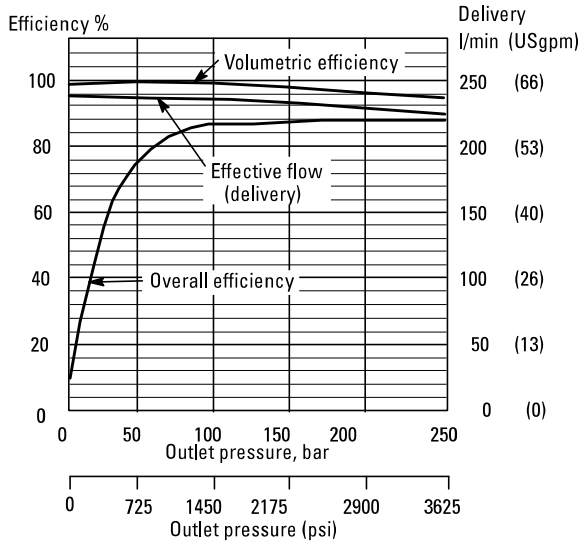

## PVH141

Delivery and efficiency versus outlet pressure at 1800 r/min

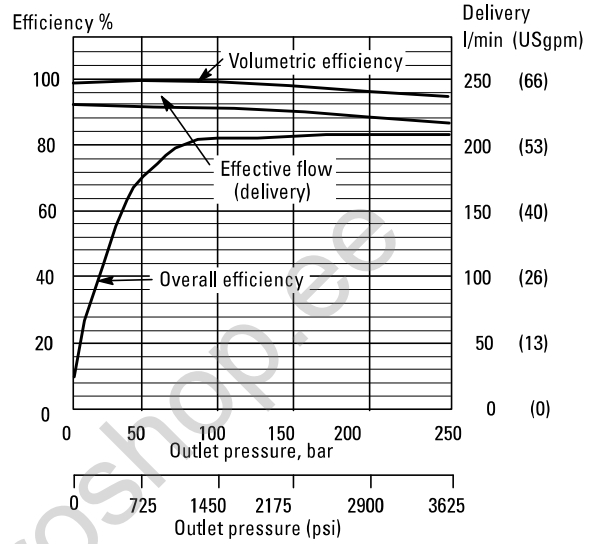

Input torque and power versus outlet pressure at 1800 r/min

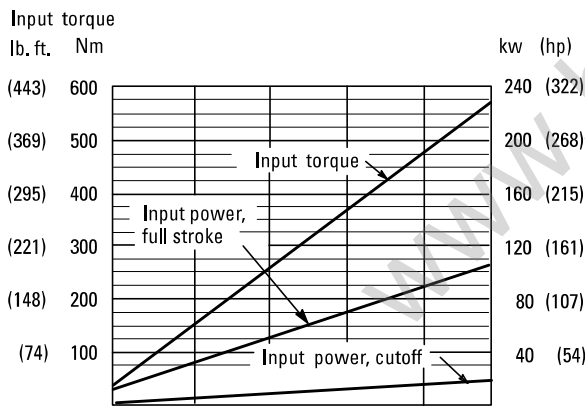

Input torque and power versus outlet pressure at 1800 r/min

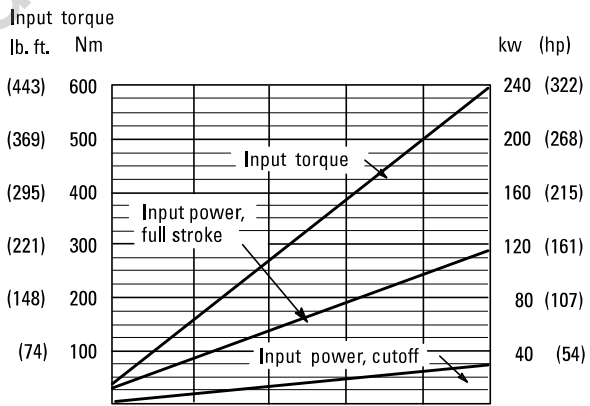

# Performance Data

Performance data is typical with SAE 10W anti-wear hydraulic oil at 50°C (120°F) and at zero pump inlet pressure, except where otherwise indicated.

## Rated Speed at Reduced Displacement and Zero Inlet Pressure

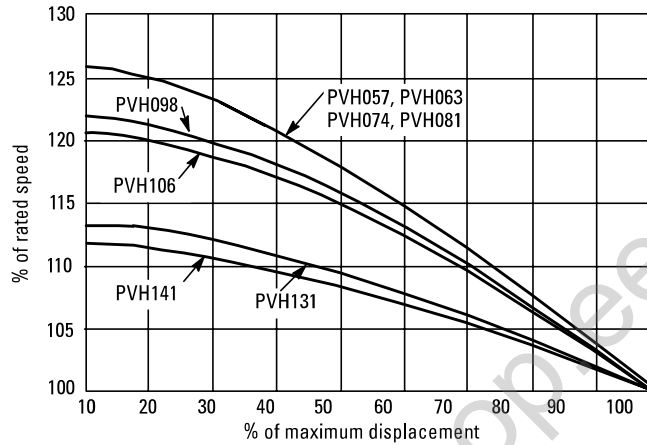

Note: Speeds at 10% displacement represent maximums at load-sense standby condition. These speeds must be reduced to rated speeds at 100% displacement before leaving standby condition, or pump damage may result.

## Effective Flow at Maximum Torque

Effective flow (delivery)  
 (USgpm)    l/min

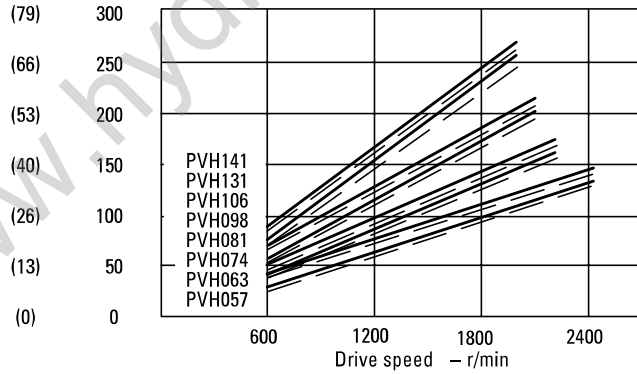

— 17 bar (250 psi)    - - - 250 bar (3625 psi)

# Performance Data

## Response Data

Model series/ Control type	Typical yoke response †	
	On stroke	Off stroke
PVH057/A**	.101 sec.	.015 sec.
PVH057/B**	.080 sec.	.014 sec.
PVH063	.101 sec.	.015 sec.
PVH063	.080 sec.	.014 sec.
PVH074/A**	.097 sec.	.015 sec.
PVH074/B**	.088 sec.	.028 sec.
PVH081	.097 sec.	.015 sec.
PVH081	.088 sec.	.028 sec.
PVH098/A**	.134 sec.	.019 sec.
PVH098/B**	.118 sec.	.029 sec.
PVH106	.134 sec.	.019 sec.
PVH106	.118 sec.	.029 sec.
PVH131/A**	.139 sec.	.019 sec.
PVH131/B**	.118 sec.	.029 sec.
PVH141	.139 sec.	.019 sec.
PVH141	.118 sec.	.029 sec.

† Based on 6900 bar/sec (100,000 psi/sec) pressure rise at rated speed and pressure.

## Sound Levels

Vickers PVH pumps are designed to provide the highest levels of system performance with noise levels within OSHA requirements. The standard models exhibit low sound levels across a wide range of operating speeds and pressures to accommodate the conditions necessary for high performance mobile vehicles. In addition, the quieter QI models provide even lower sound levels at typical in-plant conditions.

Sound is generated by a variety of factors associated with the system, machine, and environment. For more information concerning the causes and nature of noise in machinery, and methods to reduce sound levels, refer to Eaton's "More Sound Advice" bulletin 390 and "Noise Control in Hydraulic Systems" bulletin 510.

## Mobile Version – Sound Level dB(a) DIN (NFPA) ‡

Pressure bar (psi)	PVH057		PVH063		PVH074		PVH081		PVH098		PVH106		PVH131		PVH141	
	1200 r/min	1800 r/min	1800 r/min	2300 r/min	1200 r/min	1800 r/min	1800 r/min	2100 r/min	1200 r/min	1800 r/min	1800 r/min	2000 r/min	1200 r/min	1800 r/min	1800 r/min	1900 r/min
70 (1015)	71	76	77	78	71	76	74	74	71	75	80	80	76	82	81	84
140 (2030)	76	76	77	80	76	78	75	77	74	78	84	82	81	87	86	86
210 (3025)	77	81	79	83	77	81	79	79	77	82	86	84	88	89	88	87
250 (3625)	77	81	80	84	77	81	79	79	78	84	86	85	83	90	89	88

# Control Options

## Pressure Compensator Control (A)

The pump will provide a continuously modulated flow to meet changing load demands at a pre-adjusted compensator pressure. At pressures below the compensator setting, the pump will operate at maximum displacement. The compensator is available in two pressure ranges.

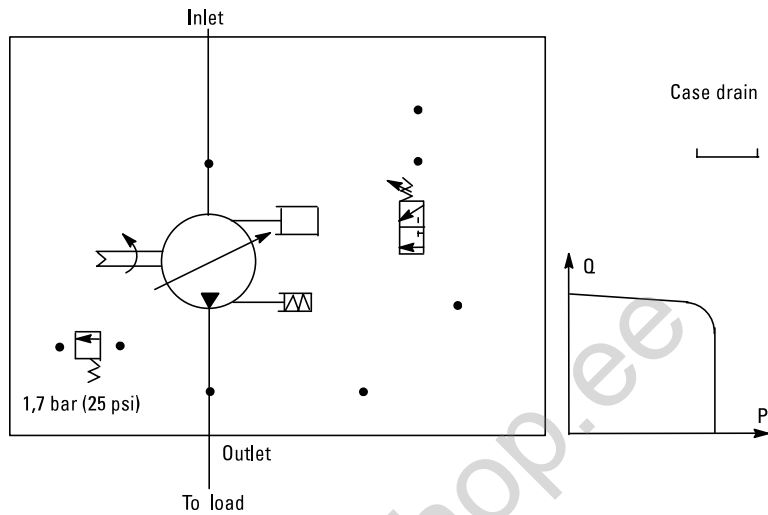

## Load Sensing and Pressure Compensator Control (B)

The pump will provide power matching of pump output to system load demand, maximizing efficiency and improving load metering characteristics of any directional control valve installed between the pump and the load.

Load sensing ensures that the pump always provides only the amount of flow needed by the load. At the same time, the pump operating pressure adjusts to the actual load pressure plus a pressure differential required for the control action. When the system is not demanding power, the load

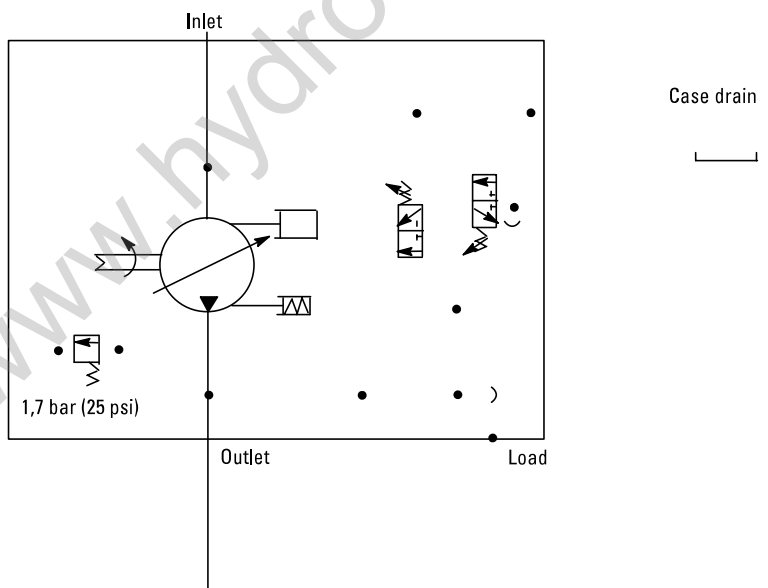

# Control Options

## Pressure and Flow Compensator with Unloading Valve for Accumulator Circuit

This pump control functions as a load-sensing pressure compensator that unloads the pump at a preset pressure and loads the pump after preset pressure drop.

## Unloading Valve Circuit (N)

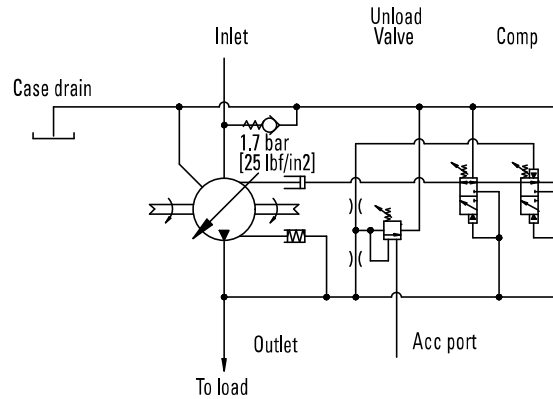

## Pressure and Torque Limiter Control (D)

The pump senses pressure and flow and starts destroking at a predetermined input torque level. The rate of flow reduction is normally tailored to follow the maximum power capability curve of the prime mover. Input torque is limited while the pressure compensator limits the system pressure.

When the input speed remains constant (i.e. industrial drives), the torque limiter acts as an input power limiter. This allows a smaller electric motor to be used if maximum pressure and maximum flow are not required at the same time. At low load levels, the control permits high pump displacement and high load speeds. Under heavy loads,

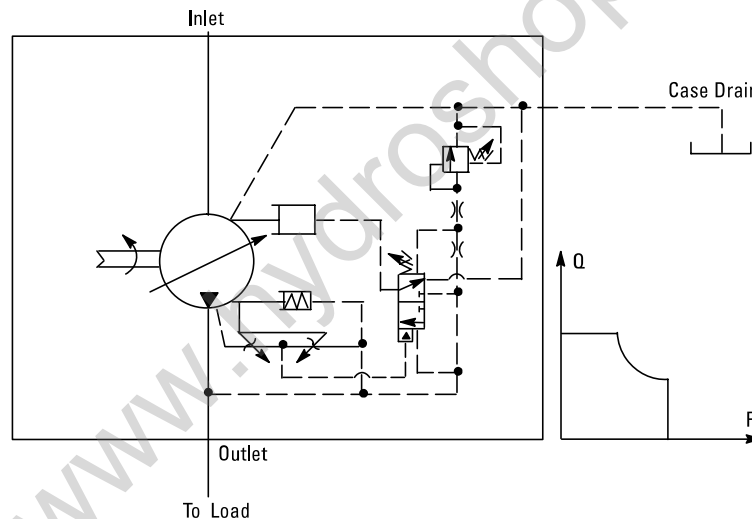

# Control Options

## Pressure and Torque Limiting, Plus Load Sensing, Control (E)

The pump's control functions like a load sensing control, but with additional torque limiting tailored to the size of the drive motor selected. The limiting function is the same as for a pressure compensator with torque limiting (see D description, previous page). The combination of the two controls provides the following benefits:

1. The energy savings of a variable displacement load sensing control.
2. The pump pressure follows the load pressure.
3. The torque control allows smaller drive motors to be used.
4. The pressure compensator de-strokes the pump as maximum pressure is reached.
5. The pump pressure can also be remotely controlled using the load sense line. The E control allows complete control of flow and pressure, either mechanically or electrically, if used with proportional valves.

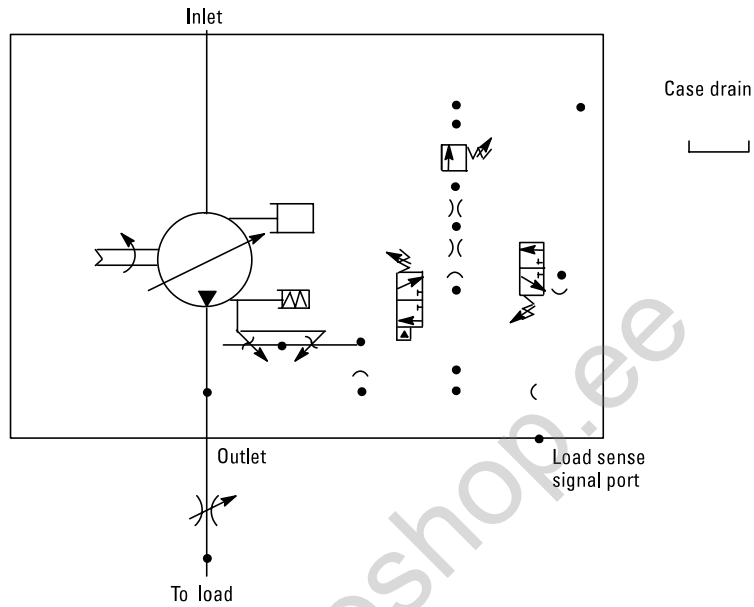

## Sumation Control (F)

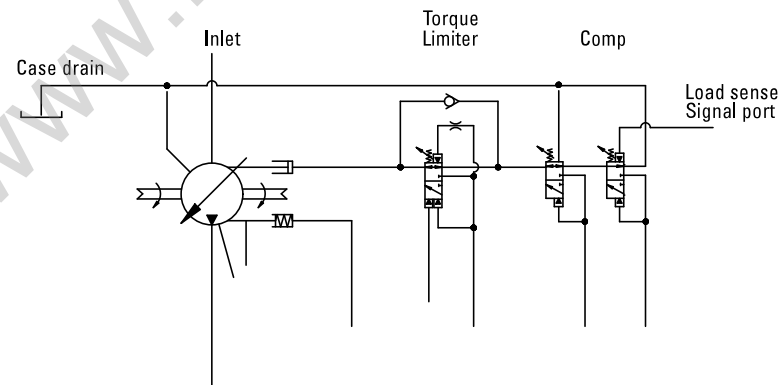

# Control Options

## Industrial Control Compensator

This pump is intended for use when multiple, remote, or electrically controlled compensating settings, with or without load sensing or, with or without torque control are desired.

Pressure compensation is obtained when an internal plug is removed, the load-sense signal port is kept plugged, and internal pilot pressure is applied to the spring chamber of the control spool. For pressure compensation with load sensing, the internal plug stays, the load-sense signal port is unplugged, and pilot pressure is externally applied.

An external relief valve (not supplied) controls spring chamber pressure. The externally adjustable spring determines the differential pressure setting of the control. Outlet pressure is limited to the value of the spring chamber (pressure port) pressure, plus control differential pressure.

(continued on next page)

## Pressure Compensating Without Load Sensing (G)

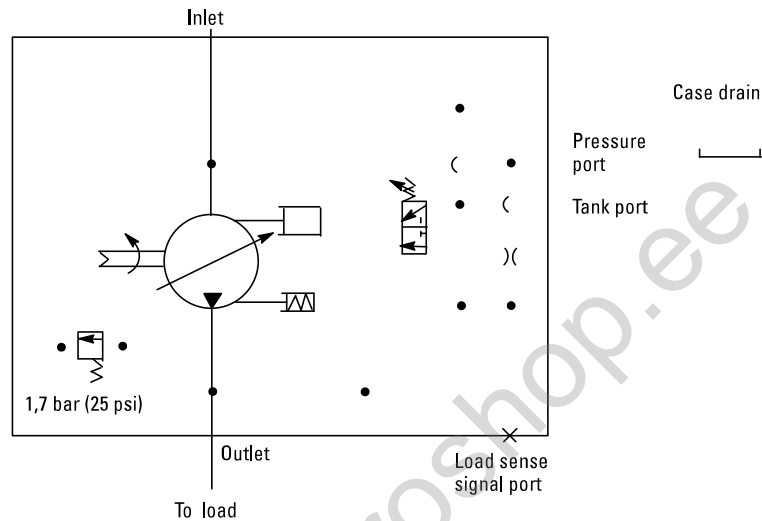

# Control Options

## Industrial Control Compensator

(continued)

Spring chamber (pilot) pressure is separated from outlet pressure by an internal orifice. Outlet pressure shifts the spool when pressure drop across the orifice reaches the differential pressure setting, and the pump de-strokes.

The relief valve can be mounted to an NFPA-D03/ISO 4401-03 pad on the pump control, or remotely located via tapping and blanking plates installed on the pad. See "Ordering Procedure", page 35, for more on valves and plates.

The standard factory-set differential pressure setting of the pump control is 20 bar (290 psi) and is not specified in the pump model number. Any other ordered differential pressure, within the control's adjustable pressure range of 17–35 bar (247–508 psi), will be specified in the model number.

### Pressure Compensating with Load Sensing (H)

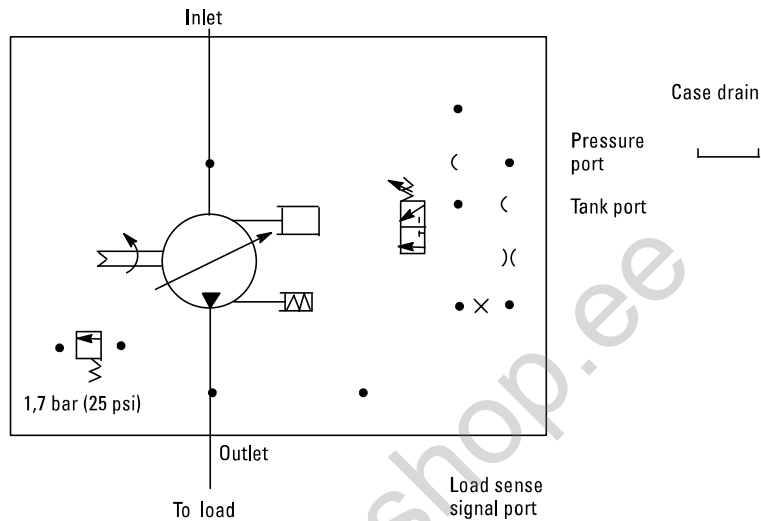

### Pressure Compensating with Load Sensing and Torque Control (J)

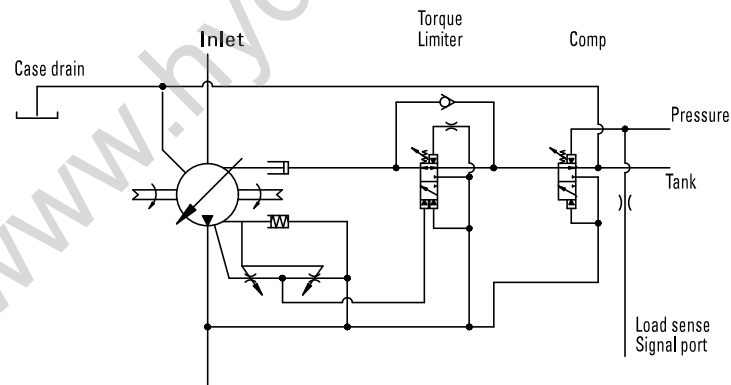

# Control Options

## Electronic Displacement Control

The displacement control utilizes a proportional flow control valve to limit pump displacement. Increasing command signal increases the pump displacement. This control has closed loop pump swashplate feedback to ensure accuracy. For further information, reference document 5092.00/EN0298/A and 5093.01/EN/1099/A.

## Electronic Displacement Control (K)

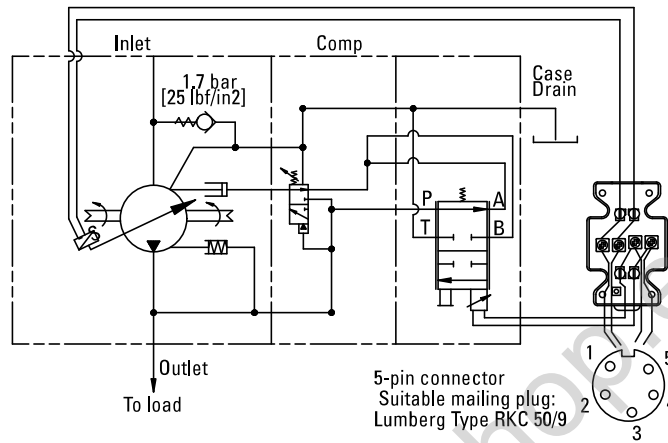

## Amplifier Card

EEA-EDC-436-A\*-14

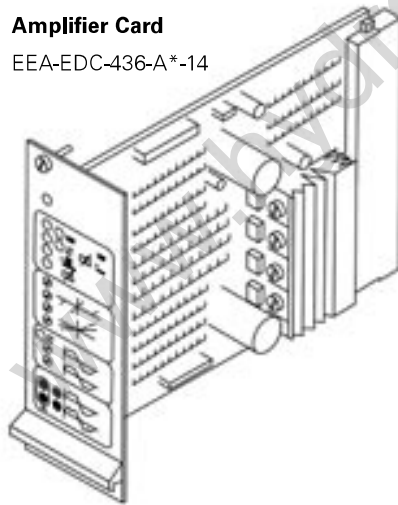

# Control Options

## Electronic Displacement Control

The displacement control utilizes a proportional flow control valve to limit pump displacement. Increasing command signal increases the pump displacement. This control has closed loop pump swashplate feedback to ensure accuracy. For further information, reference document 5092.00/EN0298/A and 5093.01/EN/1099/A.

## Electronic Displacement Control with Shuttle Valve (L)

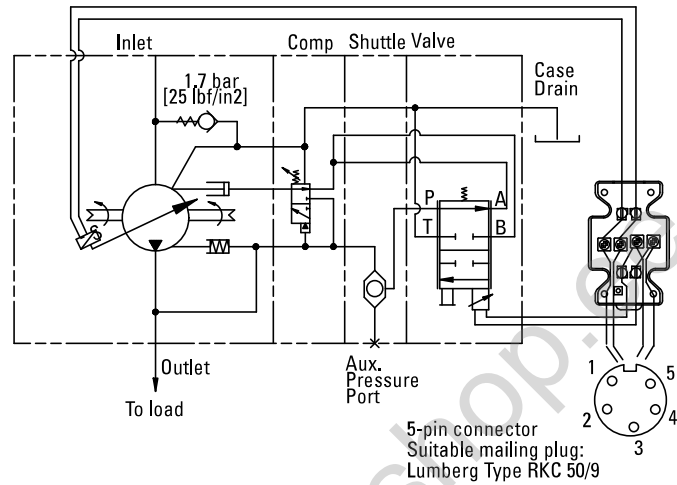

## Amplifier Card

EEA-EDC-436-A\*-14

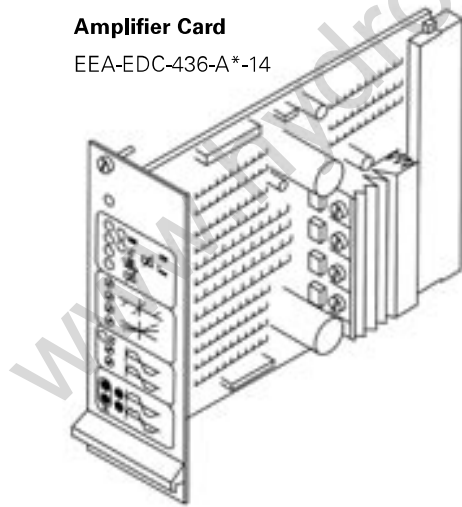

# Input Shaft Selection Data

Multiple pump arrangements can be formed by a PVH thru-drive pump and any suitable pump (single or multiple) that can be installed on the SAE "A," "B," or "C" rear-mounting option available for the thru-drive pump.

It is important to check that maximum torque values for individual pump sections, or complete pumps, occurring in a specific application will not exceed the limits tabled below.

Shaft Code	Shaft Designation	Basic Pump Series	Thru-drive Pump Series	Maximum Input Torque Nm (lb. in.)	Maximum Thru-drive Output Torque Nm (lb. in.)
N	ISO 3019/2 – E32N short straight keyed	PVH057/063	–	450 (3,980)	–
		PVH074/081	–	450 (3,980)	–
1	SAE "C" (J744-32-1) straight keyed	PVH057/063	PVH057/063	450 (3,980)	335 (2,965)
		PVH074/081	–	450 (3,980)	–
		PVH098/106	–	450 (3,980)	–
2	SAE "C" (J744-32-4) 14T 12/24 DP FRSF spline	PVH057/063	PVH057/063	640 (5,660)	335 (2,965)
		PVH074/081	–	640 (5,660)	–
		PVH098/106	–	640 (5,660)	–
3	SAE "CC" (J744-38-4) 17T 12/24 DP FRSF spline	–	PVH074/081	1215 (10,750)	460 (4,070)
		–	PVH098/106	1215 (10,750)	640 (5,660)
		PVH131/141	PVH131/141	1215 (10,750)	640 (5,660)
12	SAE "D" (J744-44-4) 13T 8/16 DP FRSF spline	PVH131/141	PVH131/141	1215 (10,750)	640 (5,660)
13	SAE "CC" (J744-38-1) straight keyed	–	PVH074/081	765 (6,770)	460 (4,070)
		–	PVH098/106	765 (6,770)	460 (4,070)
		PVH131/141	–	765 (6,770)	–
16	SAE "D" (J744-44-1) straight keyed	–	PVH131/141	1200 (10,620)	640 (5,660)

Note: Any deviation from maximum input torques must be approved by Eaton. To assure developed thru-drive loads are within PVH pump limitations, actual torque values

# Input Shaft Dimensions

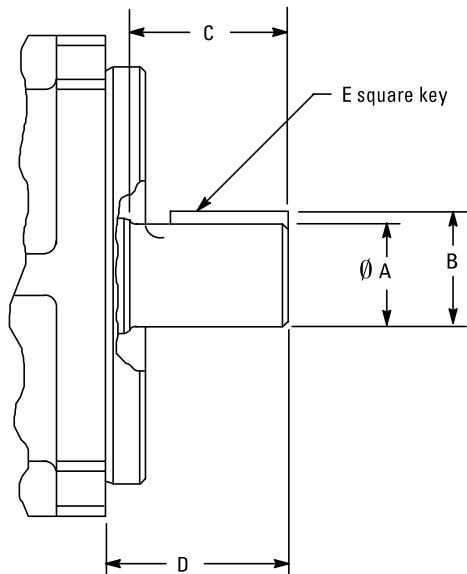

## Straight Keyed Shafts\*

Shaft Code	Shaft Designation	A	B	C	D	E
1	SAE "C" (J744-32-1)	31,75 (1,25)	35,32 (1,38)	48,0 (1,89)	56,0 (2,20)	7,93 (,312)
13	SAE "CC" (J744-38-1)	38,10 (1,50)	42,39 (1,67)	54,0 (2,12)	62,0 (2,44)	9,52 (,375)
16	SAE "D" (J744-44-1)	44,45 (1,75)	49,46 (1,95)	67,0 (2,64)	75,0 (2,95)	11,11 (,438)
N	ISO 3019/2-E32N	32,00 (1,26)	35,00 (1,38)	58,0 (2,28)	68,1 (2,68)	10,00 (,393)

# Installation Dimensions

## Basic Pump with Pressure Compensator and Load Sense Controls

Dimensions in mm (inches)

Outlet port. SAE J518C 4-bolt flange.  
Std. pressure (code 61) series for 57 to 98 sizes. High pressure (code 62) series for 131 size.

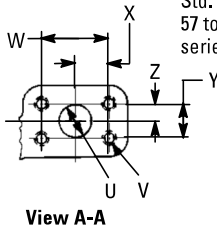
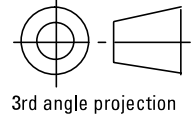

Optional drain port. For .500 O. D. tube, .750-16 UNF-2B thread (PVH057 & 74). For .625 O. D. tube, .875-14 UNF-2B thread (PVH098 & 131).

Load sense adjustment. Approx. 14 bar (200 psi) differential change per revolution of screw.

Compensator adjustment. Approx. 28 bar (400 psi) change per revolution of screw.

Centerline of outlet port

Load sensing signal port. SAE O-ring boss for .375 O. D. tube, .562-18 UNF-2B thread.

Outlet pressure gauge port. M10 thd. 25,4 (1.00) deep. O-ring boss. (plugged)

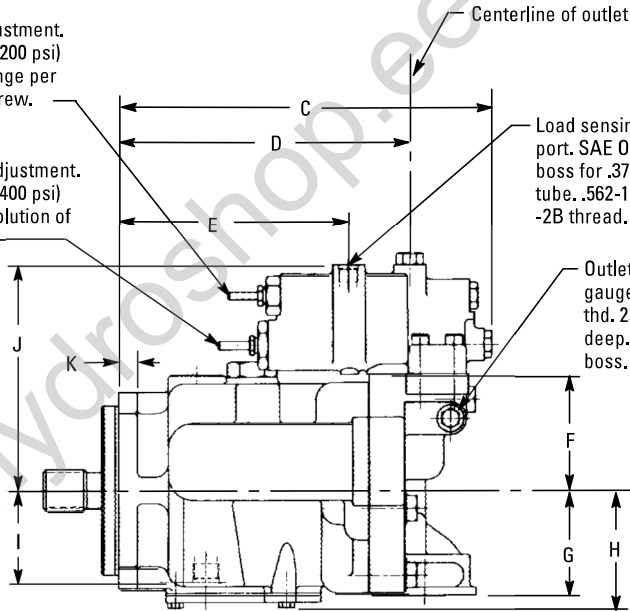
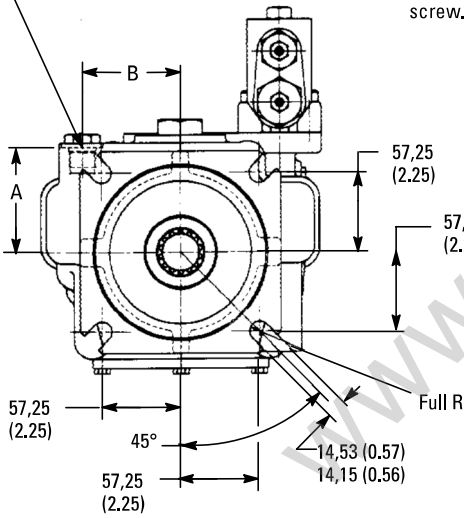

Drain port. SAE O-ring boss.

"F" model: .500-13 UNC-2B thd. 1.06 deep min. for PVH057/074. 1.19 deep min. for PVH098/131. 4 holes.

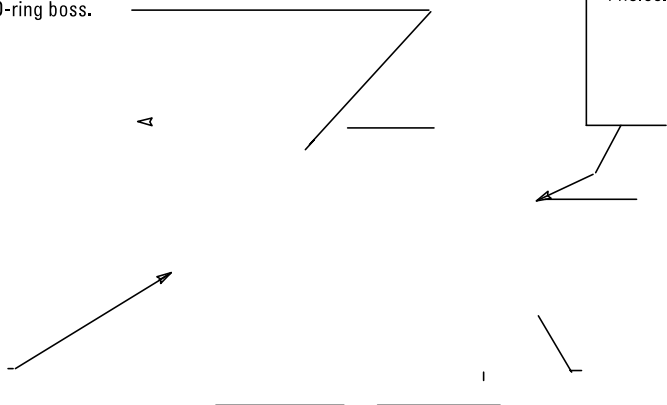

# Installation Dimensions

## Basic Pump with Pressure Compensator and Load Sense Controls

	<b>A</b>	<b>B</b>	<b>C</b>	<b>D</b>	<b>E</b>	<b>F</b>	<b>G</b>	<b>H</b>	<b>I</b>
PVH057	76,0	71,0	293,0	216,5	171,3	86,0	79,0	88,0	69,0
PVH063	(2,99)	(2,79)	(11,54)	(8,52)	(6,74)	(3,39)	(3,11)	(3,46)	(2,71)
PVH074	88,0	70,0	306,6	241,2	194,3	92,0	94,0	95,0	81,0
PVH081	(3,46)	(2,75)	(12,07)	(9,50)	(7,65)	(3,62)	(3,70)	(3,74)	(3,19)
PVH098	93,1	85,0	323,5	251,3	206,1	94,5	87,5	97,1	80,1
PVH106	(3,67)	(3,35)	(12,74)	(9,89)	(8,11)	(3,72)	(3,44)	(3,82)	(3,15)
PVH131	109,4	88,8	377,0	280,4	230,4	120,0	109,0	107,4	84,8
PVH141	(4,31)	(3,50)	(14,84)	(11,04)	(9,07)	(4,72)	(4,29)	(4,23)	(3,34)

	<b>J</b>	<b>K</b>	<b>L</b>	<b>M</b>	<b>N</b>	<b>O</b>	<b>P</b>	<b>Q</b>	<b>R</b>
PVH057	168,0	14,0	227,4	56,1	71,0	64,8	50,8	77,77	38,88
PVH063	(6,6)	(0,55)	(8,95)	(2,21)	(2,80)	(2,55)	(2,0)	(3,06)	(1,53)
PVH074	174,0	15,0	250,1	56,0	70,0	68,0	50,8	77,77	38,88
PVH081	(6,85)	(0,59)	(9,85)	(2,20)	(2,75)	(2,68)	(2,0)	(3,06)	(1,53)
PVH098	176,5	16,0	269,3	55,5	85,0	74,2	63,5	88,9	44,45
PVH106	(6,95)	(0,63)	(10,60)	(2,18)	(3,35)	(2,92)	(2,5)	(3,50)	(1,75)
PVH131	202,0	15,0	298,6	62,0	88,8	70,6	63,5	88,9	44,45
PVH141	(7,95)	(0,59)	(11,75)	(2,44)	(3,50)	(2,78)	(2,5)	(3,50)	(1,75)

	<b>S</b>	<b>T</b>	<b>U</b>	<b>V</b>	<b>W</b>	<b>X</b>	<b>Y</b>	<b>Z</b>
PVH057	42,88	21,44	25,4	M10x1,5	52,37	26,18	26,19	13,10
PVH063	(1,69)	(0,84)	(1,0)	(.375-16)	(2,06)	(1,03)	(1,03)	(0,52)
PVH074	42,88	21,44	25,4	M10x1,5	52,37	26,18	26,19	13,10
PVH081	(1,69)	(0,84)	(1,0)	(.375-16)	(2,06)	(1,03)	(1,03)	(0,52)
PVH098	50,8	25,4	25,4	M10x15	52,37	26,19	26,19	13,10
PVH106	(2,0)	(1,0)	(1,0)	(.375-16)	(2,06)	(1,03)	(1,03)	(0,52)
PVH131	50,8	25,4	31,75	M14x2,0	66,68	33,34	31,75	15,88
PVH141	(2,0)	(1,0)	(1,25)	(.500-13) (2,63)	(1,31)	(1,25)	(0,63)	

# Installation Dimensions

## Basic Pump. Rear View with Various Controls

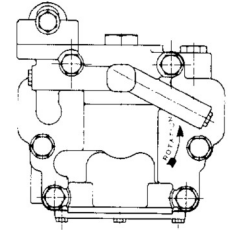

	<b>A</b>	<b>B</b>	<b>C</b>	<b>D</b>	<b>E</b>	<b>F</b>	<b>G</b>	<b>H</b>	<b>I</b>	<b>J</b>
PVH057	176,45	41,0	102,7	64,5	49,0	176,6	203,0	101,5	127,0	102,7
PVH063	(6.95)	(1.61)	(4.04)	(2.54)	(1.93)	(6.95)	(7.99)	(4.00)	(5.00)	(4.04)
PVH074	182,45	47,5	109,2	71,0	55,5	182,6	224,0	112,0	133,0	109,2
PVH081	(7.18)	(1.87)	(4.30)	(2.79)	(2.19)	(7.18)	(8.82)	(4.41)	(5.23)	(4.30)
PVH098	195,45	41,0	102,7	65,5	49,0	185,1	233,0	116,5	135,5	102,7
PVH106	(7.69)	(1.61)	(4.04)	(2.54)	(1.93)	(7.280)	(9.17)	(4.59)	(5.33)	(4.04)
PVH131	210,50	63,6	125,2	87,0	71,5	210,6	254,2	127,1	161,0	125,2
PVH141	(8.29)	(2.50)	(4.92)	(3.42)	(2.81)	(8.29)	(10.00)	(5.00)	(6.37)	(4.92)

\*Add 16,0 (.63) to dimension D for right hand rotation model.

## Pump with Pressure Compensation, Load Sense and Torque Limit Controls

www.hydropump.ee

# Installation Dimensions

## Pump with IC Compensator (Remotely Controllable Pressure Compensator, and Optional Load Sensing)

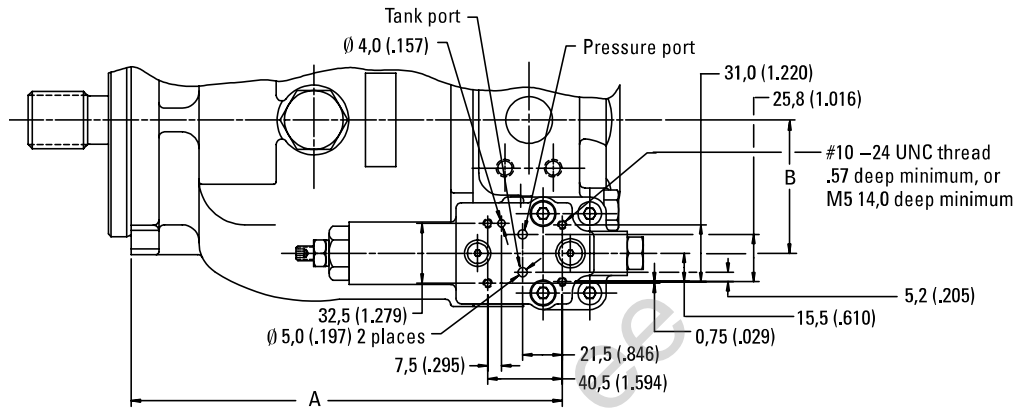

Control surface, ISO4401 size 03. Available with metric or UNC mounting holes to order

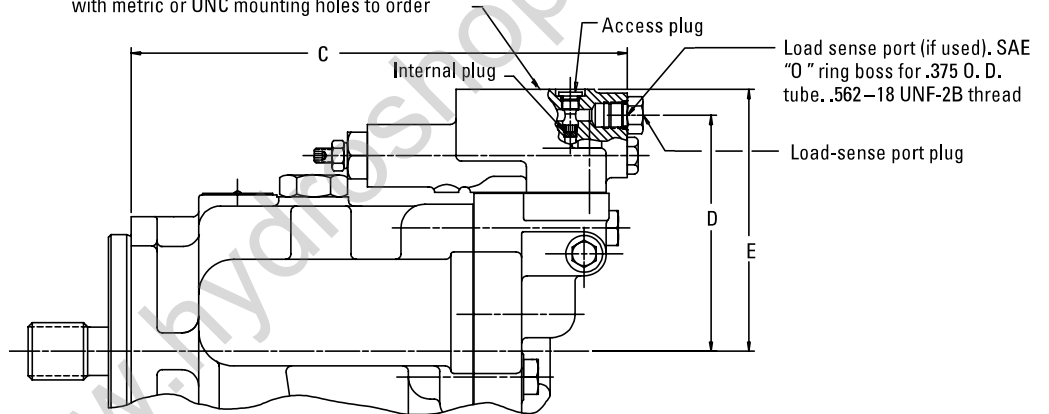

### Pressure compensator:

Remove access plug, using 1/8 inch hex wrench. Remove internal plug, using 5/32 inch hex wrench. Replace access plug

### Pressure compensator with load sensing:

Remove load-sense port plug. (Internal plug must remain in place.) Attach line to load-sense

# Installation Dimensions

## Pump with Adjustable Maximum Volume Stop

This option allows maximum pump delivery to be externally adjusted from 100 percent down to 25 percent. To assist initial priming, adjust stop to allow at least 40 percent of maximum delivery. Adjust by loosening locknut and turning adjusting rod clockwise to decrease maximum delivery, or counter-clockwise to increase maximum delivery. When desired setting is obtained, torque locknut to 25-50 Nm (18-36 lb. ft.).

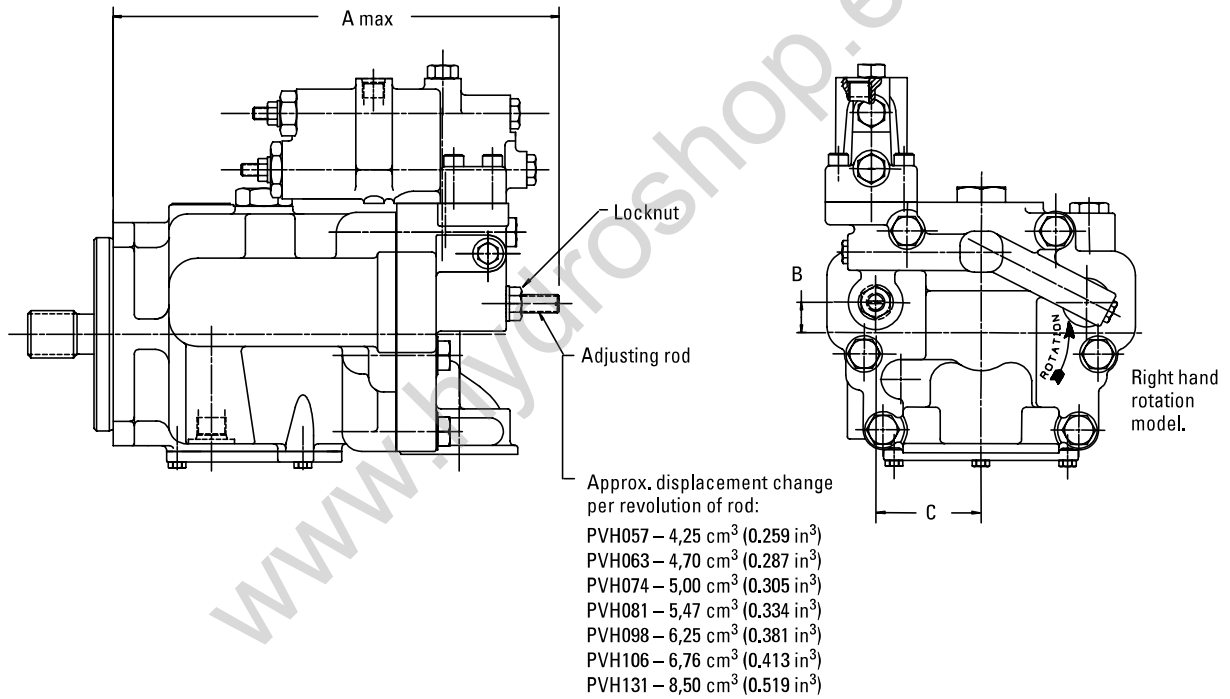

# Installation Dimensions

## Thru-drive Pumps with SAE "A" Rear Pad

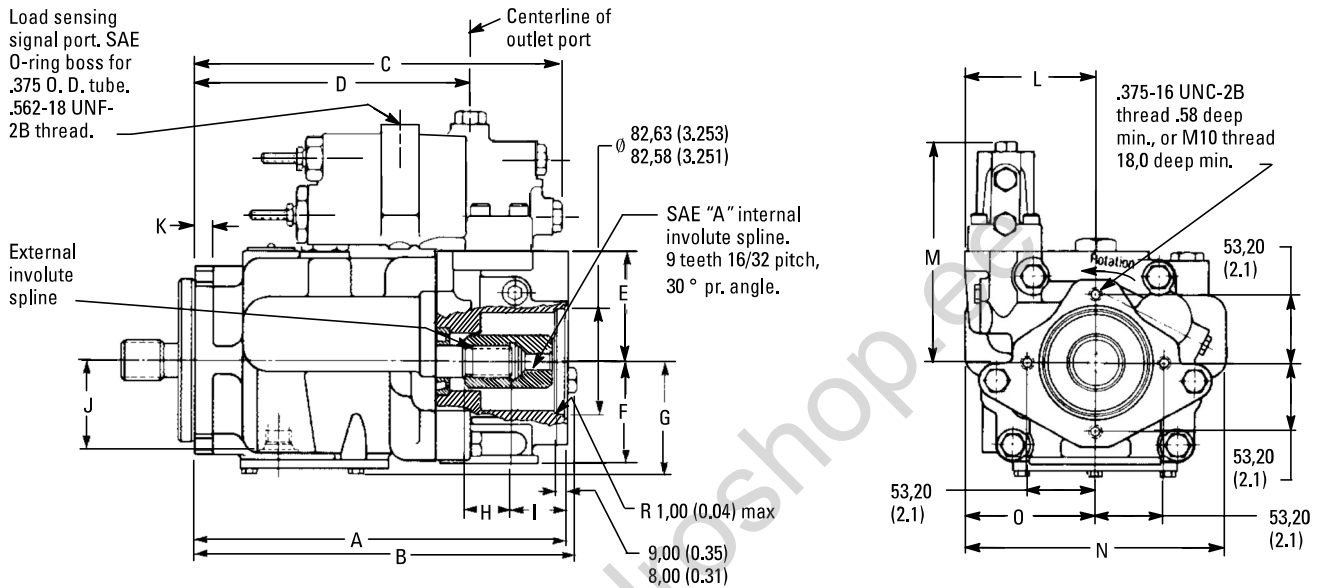

For shaft options and dimensions, see page 16 and 17. See page 26 for optional cover for rear pad.

Note: The O-ring for sealing the rear mounting pad is furnished with the pump. The rear drive coupling shown must be ordered separately; see page 23.

Right hand rotation, pressure compensated and load sensing model.

	A	B	C	D	E	F	G	H
PVH057	287,9	295,4	275,8	216,4	86,0	79,0	88,0	36,4
PVH063	(11,3)	(11,6)	(10,86)	(8,52)	(3,38)	(3,11)	(3,46)	(1,43)
PVH074	310,6	318,1	300,5	241,2	92,0	94,0	95,0	38,5
PVH081	(12,23)	(12,52)	(11,83)	(9,50)	(3,62)	(3,70)	(3,74)	(1,51)
PVH098	322,8	N/A	312,7	251,3	94,5	87,5	97,1	33,0
PVH106	(12,71)		(12,31)	(9,89)	(3,72)	(3,44)	(3,82)	(1,30)
PVH131	347,1	N/A	337,0	280,4	120,0	109,0	107,4	35,3
PVH141	(13,660)		(13,27)	(11,04)	(4,72)	(4,29)	(4,23)	(1,39)

# Installation Dimensions

## Thru-drive Pumps with SAE "B" Rear Pad Adapter

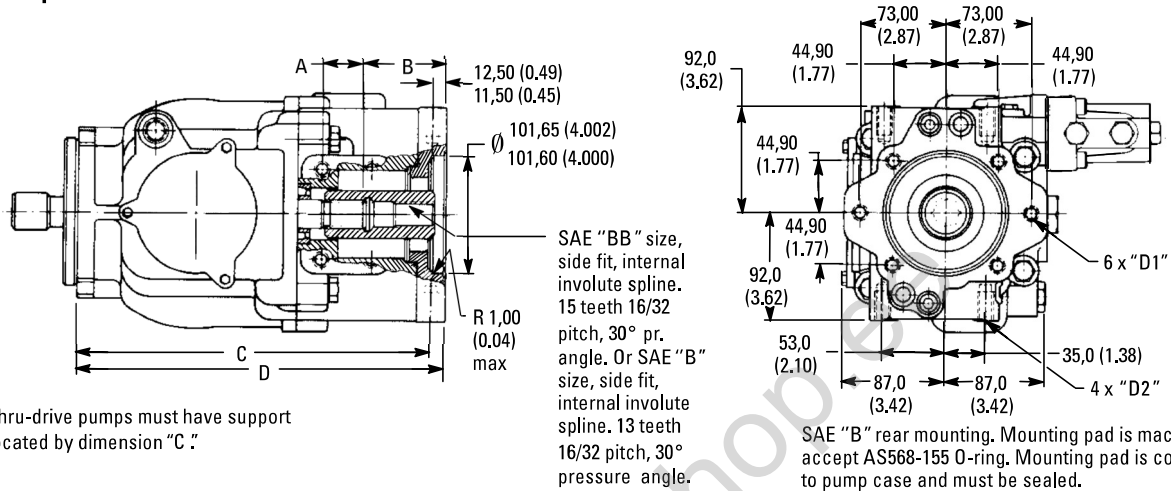

## Thru-drive Pumps with SAE "C" Rear Pad Adapter

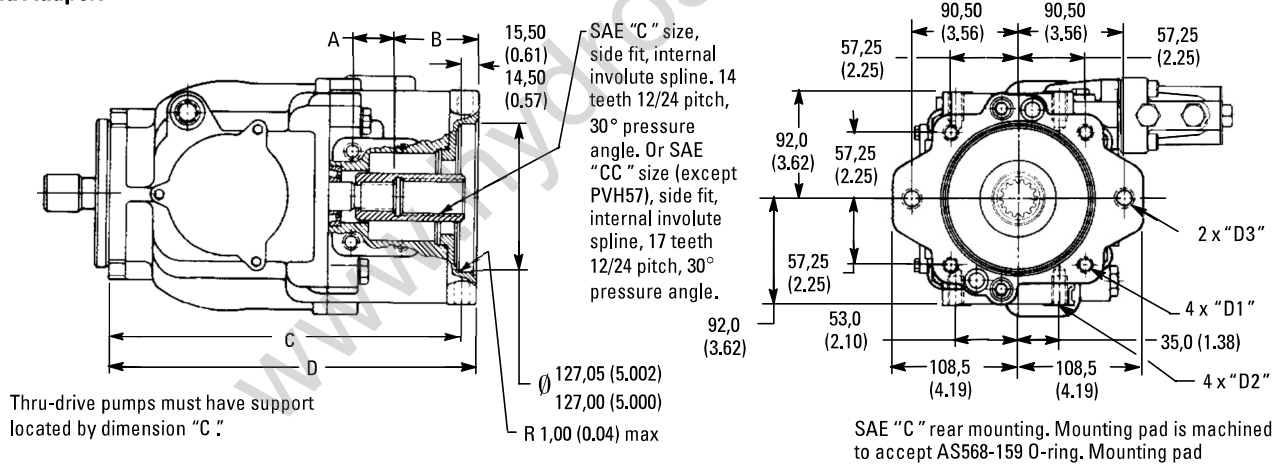

# Installation Dimensions

## Thru-drive Flange Kit and Shaft Coupling

Front Pump Model Series	SAE (J744) Mounting Flange for Rear Pump	Mounting Flange Adapter Kit Number*		Coupling Part Number**
		Metric Threads	Inch Threads	
PVH057	A (J744-82-2)	None required	None required	526682
PVH063	B (J744-101-2/4)	876394	876390	526694
	BB (J744-101-2/4)	876394	876390	526695
	C (J744-127-2/4)	876392	876389	526696
PVH074	A (J744-82-2)	None required	None required	864460
PVH081	B (J744-101-2/4)	876394	876390	864457
	BB (J744-101-2/4)	876394	876390	864459
	C (J744-127-2/4)	876392	876389	864458
	CC (J744-127-2/4)	876392	876389	864461
PVH098	A (J744-82-2)	None required	None required	877039
PVH106	B (J744-101-2/4)	876394	876390	877040
PVH131	BB (J744-101-2/4)	876394	876390	877044
PVH141	C (J744-127-2/4)	876392	876389	877045
	CC (J744-127-2/4)	876392	876389	877046

\*The basic PVH thru-drive pump has an SAE "A" pad on the rear. An SAE "B" or "C" pad rear mounting requires flange adapters. Required adapters can be provided if specified in the pump model code. The best combination of price, availability and flexibility is achieved by ordering a PVH SAE "A" thru-drive model and the applicable PVH mounting flange adapter separately. For example, a PVH074C-RCF-3S-10-C25-31 may also be ordered as a PVH074C-RAF-3S-10-C25-31 and a 876389 flange adapter.

\*\* Thru-drive shaft couplings must be ordered separately to drive the second pump.

## Typical Rear Pumps for Thru-drive Assemblies

Mounting	Piston pump Series	Shaft Code	Vane pump Series	Shaft Code	
SAE A	PVQ10/13	3	V10	11	
			V20	62	
SAE B	PVQ20/32	3	20V	151	
			PVQ40/45	25V	11
				PVE19/21	9
SAE BB	PVE19/21	2			

# Installation Dimensions

**ISO 3019/2-125B4HW  
Mounting Flange for PVH057  
and PVH074 Pumps**

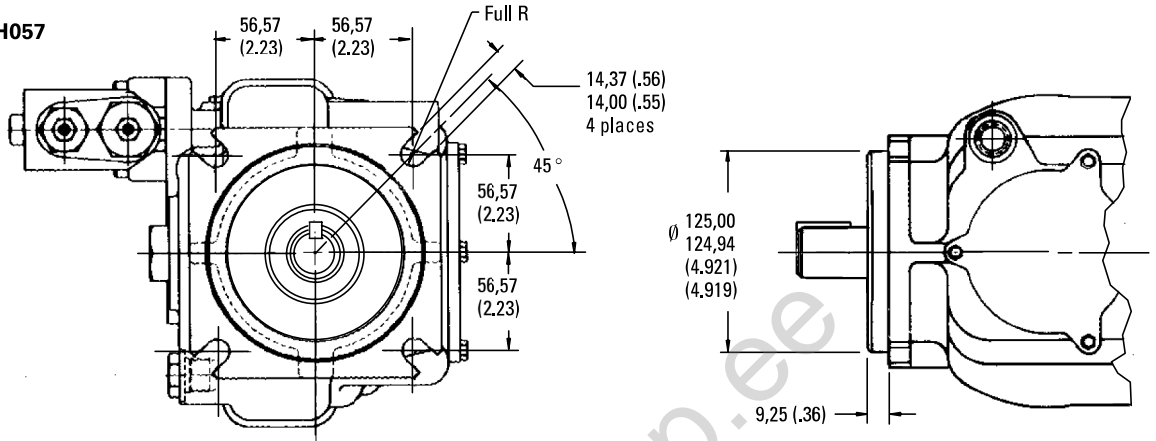

**SAE 2-bolt/4-bolt Mounting  
("027" Option) for PVH057,  
PVH074 and PVH098 Pumps**

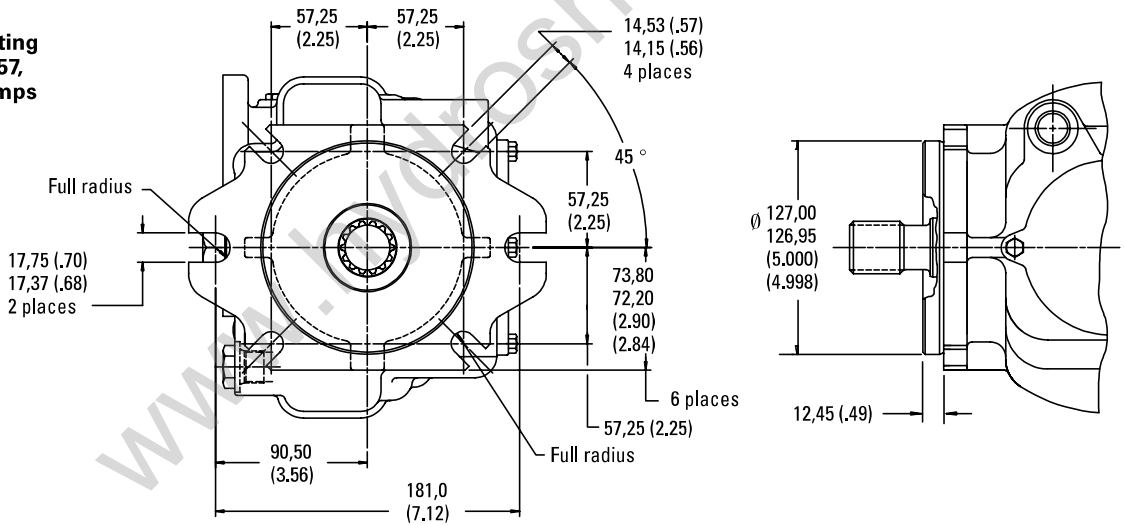

# Installation Dimensions

## Pumps for Shaft-up Operation (Vertical Mount, "057" Option)

Model	Dim. "A"
PVH057	25,68/24,94
PVH063	(1,01/0,98)
PVH074	26,64/25,90
PVH081	(1,05/1,02)
PVH098	25,82/25,08
PVH106	(1,02/0,99)
PVH131	25,12/24,38
PVH141	(,99/0,96)

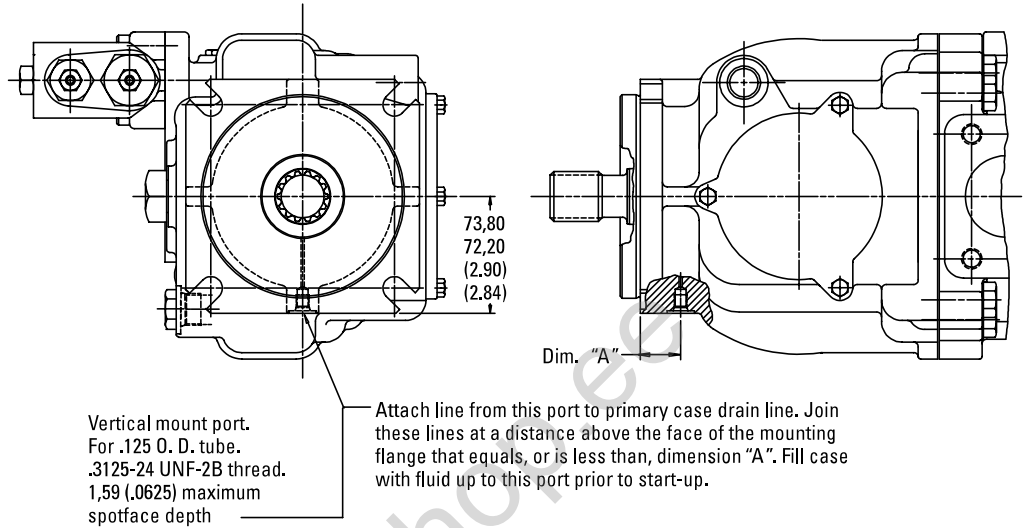

## Model FB-C4-10 Foot Mounting Kit for All PVH Pumps

Each kit (part no. 02-143419) includes bracket shown and four screws for mounting to the pump. Kits are not included with pumps and must be ordered separately by model number.

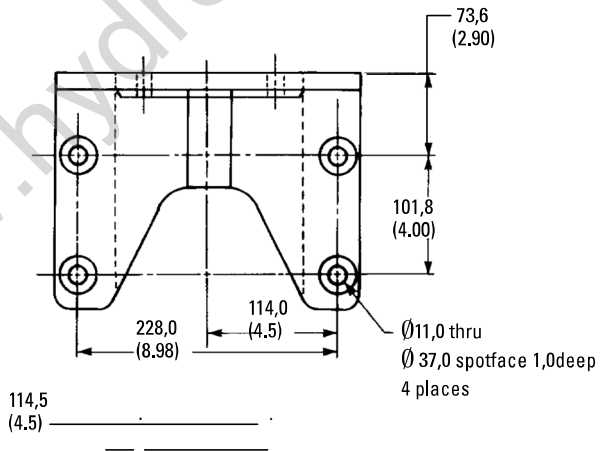

# Application Data

## Hydraulic Fluids and Temperature Ranges

Use anti-wear hydraulic oil, or automotive type crankcase oil (designations SC, SD, SE or SF) per SAE J183 FEB80.

Select a viscosity grade that will allow optimum viscosity, between 40 cSt (180 SUS) and 16cSt (80 SUS), to be achieved.

Cold start capability at 5000 cSt. Max. intermittent temp. 104° C (220° F).

For further information, see 694.

## Fluid Cleanliness

Proper fluid condition is essential for long and satisfactory life of hydraulic components and systems. Hydraulic fluid must have the correct balance of cleanliness, materials and additives for protection against wear of components, elevated viscosity and inclusion of air.

Essential information on the correct methods for treating hydraulic fluid is included in Eaton publication 561; "Vickers Guide to Systemic Contamination Control," available from your local Eaton distributor or by contacting Eaton. Recommendations on filtration and the selection of products to control fluid condition are included in 561.

Recommended cleanliness levels, using petroleum oil under common conditions, are based on the highest fluid pressure levels in the system and are coded in the chart below. Fluids other than petroleum, severe service cycles or temperature extremes are cause for adjustment of these cleanliness codes. See Eaton publication 561 for exact details.

Eaton products, as any components, will operate with apparent satisfaction in fluids with higher cleanliness codes than those described. Other manufacturers will often recommend

levels above those specified. Experience has shown, however, that life of any hydraulic components is shortened in fluids with higher cleanliness codes than those listed below. These codes have been proven to provide a long trouble-free service life for the products shown, regardless of the manufacturer.

## Drive Data

Mounting attitude should be horizontal. See preceding page for vertical mount option. Consult your local Vickers representative if a different arrangement is required.

Direction of shaft rotation, viewed at the prime mover end, must be as indicated in the model designation on the pump. See "5" in Model Codes, page 6.

Drive arrangement should be by direct drive through a flexible coupling. Check pump installation drawing for concentricity and squareness tolerances.

Torque capability of shafts in basic (non-thru-drive) pumps is well in excess of that needed for operation at rated pressure and maximum displacement. Limitations for multiple pumps formed by PVH thru-drives as front-end sections are specified in the chart on page 18.

Moment of Inertia (Single Pump Rotating Group)		
Model	Nm.sec <sup>2</sup>	(lb.in.sec <sup>2</sup> )
PVH057	0,0054	(0.0475)
PVH063	0,0054	(0.0447)
PVH074	0,0078	(0.0692)
PVH081	0,0073	(0.0643)
PVH098	0,0134	(0.1189)
PVH106	0,0123	(0.1086)
PVH131	0,0210	(0.1862)
PVH141	0,0210	(0.1856)

## Cleanliness Codes For Petroleum Oil Usage

Product	System Pressure Level		
	2000 psi	2000-3000 psi	3000+ psi
Vane pumps, fixed	20/18/15	19/17/14	18/16/13
Vane pumps, variable	18/16/14	17/15/13	
Piston pumps, fixed	19/17/15	18/16/14	17/15/13
Piston pumps, variable	18/16/14	17/15/13	16/14/12
Directional valves	20/18/15	20/18/15	19/17/14
Proportional valves	17/15/12	17/15/12	15/13/11

# Weights, Ordering, Installation/Start-up

## Weights in kg (lb)\*

Pump Size	Basic Pump	Thru-drive Pump SAE "A"
PVH057	30-36	31-37
PVH063	(66-79)	(68-82)
PVH074	39-45	42-48
PVH081	(86-99)	(93-106)
PVH098	43-49	44-50
PVH106	(95-108)	(97-110)
PVH131	60-66	62-68
PVH141	(132-145)	(137-150)

\*Approximate dry weights. Weight for a given model depends upon the type of pump control selected.

## Ordering Procedure

Order PVH pumps by the full model designation. Pump displacement, mounting flange type, direction of rotation, pump configuration, shaft end type, shaft seals, pressure adjustment range, specific control functions, and torque limiter settings are all specified in the full model code.

Various Vickers® relief valves from Eaton are suitable for use with the "IC" compensator and must be ordered separately.

Examples include:

- DGMC2-3-AT-BT (plus DG4V-3-8C directional valve) for remotely and electrically controlled dual-pressure compensation, and standby no-flow pump operation in the load sensing mode.
- DGMC-3-PT-FW-30 crossline relief module (with DG4V3-8C

- DGMC-3-AT-BT (plus DG4V-3-0A directional valve) for remotely and electrically selected dual-pressure compensation.
- C175-F-20 (plus blanking plate DGMA-3-B-11 and tapping plate DGMA-T2-20-S) for remote control of pressure compensation.
- CVGC-3-S12 for non-remote control of pressure compensation.
- DGMC-3-PT-FW-30 crossline relief module (with blanking plate DGMA-3-B-11) for non-remote control of pressure compensation.

Contact your Vickers representative for additional information on the application and ordering of relief valves.

If the pump has the vertical-mount option, attach a secondary drain line as noted on page 29.

Maximum continuous pressure at the case drain port must not exceed 0,5 bar (7 psi). For multiple pump arrangements that include non-PVH sections, the requirements of the non-PVH units must be considered.

[www.hydroshop.ee](http://www.hydroshop.ee)