

**SERIE  
2000**

[www.hydrosshop.ee](http://www.hydrosshop.ee)

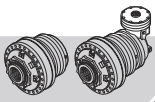

2 IDENTIFICAZIONE DEL PRODOTTO 2 PRODUCT IDENTIFICATION

2 PRODUKTKENNZEICHNUNG

2.1 Composizione di montaggio

2.1 Assembly layout

2.1 Montageaufbau

1. MOTORI  
MOTORS  
MOTOREN  
MOTEURS  
MOTOR  
MOTOR

2. ENTRATE  
INPUTS  
EINGÄNGE  
ENTREES  
ENTRADAS  
ENTRADAS

3. FRENI  
BRAKES  
BREMSEN  
FREINS  
FRENOS  
FREIOS

4. GRUPPI RIDUZIONE  
REDUCTION GEAR UNITS  
UNTERSETZUNGSGETRIEBE  
GROUPES DE REDUCTION  
GRUPOS REDUCCIÓN  
GRUPOS REDUÇÃO

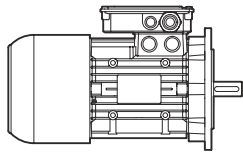

1.1 Motore elettrico  
Electrical motor  
Elektromotor  
Moteur électrique  
Motor eléctrico  
Motor elétrico

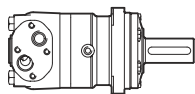

1.2 Motore idraulico  
Hydraulic motor  
Hydraulikmotor  
Moteur hydraulique  
Motor hidráulico  
Motor hidráulico

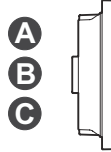

2.1 Entrata standard  
Standard input  
Standardeingang  
Entrée standard  
Entrada standard  
Entrada padrão

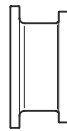

2.2 Accoppiamento motore elettrico  
Electrical motor coupling  
Kupplung Elektromotor  
Accouplement moteur électrique  
Acoplamiento motor eléctrico  
Acoplagem motor elétrico



2.3 Accoppiamento motore idraulico  
Hydraulic motor coupling  
Kupplung Hydraulikmotor  
Accouplement moteur hydraulique  
Acoplamiento motor hidráulico  
Acoplagem motor hidráulico

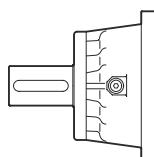

2.4 Entrata veloce  
High-speed input  
Schneller Eingang  
Entrée rapide  
Entrada rápida  
Entrada rápida

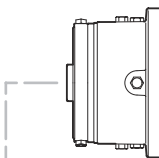

3.1 Freno negativo  
Negative brake  
Negativbremse  
Frein négatif  
Freno negativo  
Freio negativo

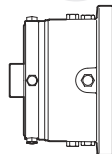

3.2 Freno negativo con accoppiamento per motore idraulico  
Negative brake with hydraulic motor coupling  
Negativbremse mit Kupplung für Hydraulikmotor  
Frein négatif avec accouplement moteur hydraulique  
Freno negativo con acoplamiento para motor hidráulico  
Freio negativo com acoplagem para motor hidráulico

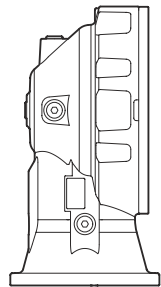

4.1 Stadio angolare  
Angular stage  
Winkelstufe  
Etage angulaire  
Etapa angular  
Estádio angular

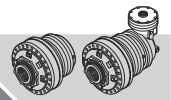

2 IDENTIFICATION DU PRODUIT

2 IDENTIFICACIÓN DEL PRODUCTO

2 IDENTIFICAÇÃO DO PRODUTO

2.1 Composition de montage

2.1 Composición de montaje

2.1 Composição de montagem

4. GRUPPI RIDUZIONE  
REDUCTION GEAR UNITS  
UNTERSETZUNGSGETRIEBE  
GROUPES DE REDUCTION  
GRUPOS REDUCCIÓN  
GRUPOS REDUÇÃO

4.2 Stadio planetario  
Planetary stage  
Planetenstufe  
Etage planétaire  
Etapa planetario  
Estádio planetário

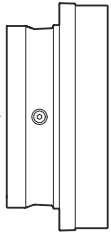

5. USCITE  
OUTPUTS  
AUSGÄNGE  
SORTIES  
SALIDAS  
SAÍDAS

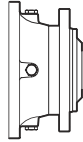

5.1 Uscita M  
M Output  
Ausgang M  
Sortie M  
Salida M  
Saída M

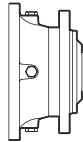

5.2 Uscita B  
B Output  
Ausgang B  
Sortie B  
Salida B  
Saída B

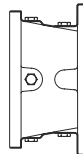

5.3 Uscita S  
S Output  
Ausgang S  
Sortie S  
Salida S  
Saída S

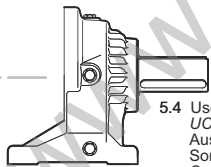

5.4 Uscita UC  
UC Output  
Ausgang UC  
Sortie UC  
Salida UC  
Saída UC

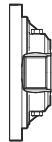

5.5 Uscita FS  
FS Output  
Ausgang FS  
Sortie FS  
Salida FS  
Saída FS

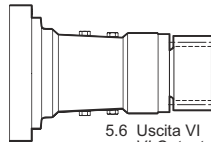

5.6 Uscita VI  
VI Output  
Ausgang VI  
Sortie VI  
Salida VI  
Saída VI

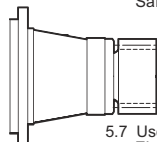

5.7 Uscita ZI  
ZI Output  
Ausgang ZI  
Sortie ZI  
Salida ZI  
Saída ZI

6. ALBERI  
SHAFTS  
WELLEN  
ARBRES  
EJES  
EIXOS



S



C



H



E



S



C



H



E



S



C



E



I

7. ACCESSORI USCITA  
OUTPUT ACCESSORIES  
ZUBEHÖR AUSGANG  
ACCESSOIRES SORTIE  
ACCESORIOS SALIDA  
ACESSÓRIOS SAÍDA



7.1 Flangia presa moto-tipo 28  
Drive intake flange – type 28  
Antriebsflansch – Typ 28  
Bride prise mouvement – type 28  
Brida toma movimiento – tipo 28  
Flange tomada movimento – tipo 28



7.4 Flangetta di fissaggio-tipo 12  
End plate – type 12  
Befestigungsflansch – Typ 12  
Bride de fixation – type 12  
Brida de sujeción – tipo 12  
Pequena flange de fixação – tipo 12



7.2 Boccola scanalata-tipo 29  
Splined bush – type 29  
Nutbuchse – Typ 29  
Douille cannelée – type 29  
Buje acanalado – tipo 29  
Disco com ranhuras – tipo 29



7.3 Pignone-tipo 16  
Pinion – type 16  
Nutbuchse – Typ 16  
Douille cannelée – type 16  
Buje acanalado – tipo 16  
Disco com ranhuras – tipo 16



7.5 Calettatore per attrito  
Friction shrink disc  
Schrumpfscheibe  
Frette de serrage par frottement  
Engargolador por fricción  
Encaixador por atrito



7.6 Albero scanalato-tipo 27  
Splined shaft – type 27  
Keilwelle – Typ 27  
Arbre cannelé – type 27  
Eje acanalado – tipo 27  
Veio com ranhuras – tipo 27

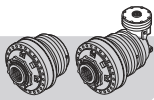

**2.2 Designazione**

I riduttori epicicloidali Reggiana Riduttori vengono identificati mediante una sigla composta nel seguente modo:

**2.2 Designation**

*The Reggiana Riduttori planetary reduction gears are identified by an acronym made up in the following way:*

**2.2 Bezeichnung**

Die Planetengetriebe von Reggiana Riduttori sind durch einen Code gekennzeichnet, der folgende Bedeutung hat:

<b>RR</b>	<b>510</b>	<b>T</b>	<b>FS</b>	<b>65.60</b>	<b>RF</b>
<p><b>Configurazione ingresso (opzionale) / Input configuration (optional) / Konfiguration am Eingang (optional)</b></p> <p>- Ingresso standard / <i>Standard input</i> / Standardeingang  <b>RF</b> Predisposizione RF / <i>Setup RF</i> / Auslegung RF  <b>BOC</b> Predisposizione BOC / <i>Setup BOC</i> / Auslegung BOC</p> <hr/> <p><b>Rapporto di riduzione / Reduction ratio / Untersetzungsverhältnis</b></p> <p>i = 3 - 3000</p> <hr/> <p><b>Tipo di uscita / Type of output / Typ Ausgang</b></p> <p><b>MS/BS</b> Maschio scanalato / <i>Male splined</i> / Zum Einstecken mit Nut  <b>MC/BC</b> Maschio cilindrico / <i>Male cylindrical</i> / Zum Einstecken zylindrisch  <b>MH/BH</b> Maschio cavo / <i>Male hollow</i> / Zum Einstecken hohl  <b>ME/BE</b> Maschio esagonale / <i>Male hexagonal</i> / Zum Einstecken sechseckig /  <b>SS</b> Rinforzato scanalato / <i>Splined reinforced</i> / Verstärkt mit Nut  <b>SC</b> Rinforzato cilindrico / <i>Cylindrical reinforced</i> / Verstärkt zylindrisch  <b>SE</b> Rinforzato esagonale / <i>Hexagonal reinforced</i> / Verstärkt sechseckig  <b>SI</b> Rinforzato con pignone integrale / <i>Reinforced with integral pinion</i> / Verstärkt mit integriertem Ritzel  <b>UC</b> Maschio cilindrico, con piedi / <i>Male cylindrical, with feet</i> / Zum Einstecken zylindrisch, mit Füßen  <b>FS</b> Femmina scanalato / <i>Female splined</i> / Zum Aufstecken mit Nut  <b>VI</b> Pignone integrale (doppio centraggio) / <i>Integral pinion (double centring)</i> / Integriertes Ritzel (doppelte Zentrierung)  <b>ZI</b> Pignone integrale (con flangia) / <i>Integral pinion (with flange)</i> / Integriertes Ritzel (mit Flansch)</p> <hr/> <p><b>Numero stadi / Number of stages / Anzahl Stufen</b></p> <p>— Singolo stadio / <i>Single stage</i> / Einstufig  <b>D</b> Doppio stadio / <i>Double stage</i> / Zweistufig  <b>T</b> Triplo stadio / <i>Triple stage</i> / Dreistufig  <b>Q</b> Quadruplo stadio / <i>Quadruple stage</i> / Vierstufig</p> <hr/> <p><b>Grandezza / Size / Grösse</b></p> <p>65, 105, 110, 210, 310, 510, 710, 810, 1010, 1700</p> <hr/> <p><b>Esecuzione</b></p> <p><b>RR</b> Riduttore lineare  <b>RA</b> Riduttore angolare</p>					

Nel caso sia possibile montare più di una grandezza di coppia conica in ingresso, le diverse alternative per le combinazioni risultanti si indicano con (A) e (B), a partire dall'alternativa con coppia conica più piccola.  
 Esempio: RA1700 (A), RA1700 (B).

*If it is possible to mount more than one bevel gear size in input, the different alternatives for the combinations are indicated with (A), (B) and (C) starting from the alternative with the smallest bevel gear.*  
*Example: RA1700 (A), RA1700 (B).*

Falls mehrere Kegelpaargrößen am Eingang montiert werden können, werden die alternativen Kombinationen mit (A), (B) und (C) angegeben, ausgehend vom kleinsten Kegelpaar.  
 Beispiel: RA1700 (A), RA1700 (B).

**2.3 Marcatura del prodotto e designazione del tipo**

Tutti i prodotti Reggiana Riduttori sono dotati di targhetta di identificazione, posizionata in modo da risultare facilmente leggibile, anche dopo l'installazione.

La seguente figura mostra un esempio di targhetta.

**2.3 Product marking and type designation**

*All Reggiana Riduttori products have an id plate positioned so as to be easily readable also after installation.*

*The following figure shows an example of a plate.*

**2.3 Produktkennzeichnung und Typschild**

Alle Produkte von Reggiana Riduttori weisen ein Typenschild auf, das so angebracht ist, dass es auch nach der Installation leicht abgelesen werden kann.

Die Abbildung unten zeigt ein Beispi.



	Legenda	Legend	Legende
<b>A</b>	Tipo di riduttore e rapporto	<i>Reduction gear type and ratio</i>	Untersetzungstyp und Untersetzungsverhältnis
<b>B</b>	Codice identificativo di ordinazione	<i>ID code for ordering</i>	Identifizierungscode der Bestellung
<b>C</b>	N° progressivo di matricola	<i>Progressive serial number</i>	Fortlaufende Seriennummer
<b>D</b>	Mese/anno di produzione	<i>Months/year of production</i>	Monat/Baujahr



## 2.2 Designation

Les réducteurs épicycloïdaux Reggiana Riduttori sont identifiés au moyen d'un sigle composé de la manière suivante:

## 2.2 Denominación

Los reductores epicicloidales Reggiana Riduttori están identificados por una sigla formada como sigue:

## 2.2 Designação

Os redutores epicicloidais Reggiana Riduttori são identificados mediante uma referência composta no seguinte modo:

RR	510	T	FS	65.60	RF
<p><b>Configuración a l'entrèe (en option) / Configuración en entrada (opcional)</b>  <b>Configuração em entrada (opcional)</b></p> <p>- Entrèe standard / <i>Entrada estándar</i> / Entrada padrão  <b>RF</b> Prèrèglage RF / <i>Predisposición RF</i> / Predisposição RF  <b>BOC</b> Prèrèglage BOC / <i>Predisposición BOC</i> / Predisposição BOC</p> <p><b>Rapport de réduction / Relación de reducción / Relação de redução</b>  <i>i</i> = 3 - 3000</p> <p><b>Type de sortie / Tipo de salida / Tipo de saída</b></p> <p><b>MS/BS</b> Mâle cannelé / <i>Macho acanalado</i> / Macho com ranhuras  <b>MC/BC</b> Mâle cylindrique / <i>Macho cilíndrico</i> / Macho cilíndrico  <b>MH/BH</b> Mâle creux / <i>Macho hueco</i> / Macho ôco  <b>ME/BE</b> Mâle hexagonal / <i>Macho hexagonal</i> / Macho hexagonal  <b>SS</b> Renforcé cannelé / <i>Reforzado acanalado</i> / Reforçado com ranhuras  <b>SC</b> Renforcé cylindrique / <i>Reforzado cilíndrico</i> / Reforçado cilíndrico  <b>SE</b> Renforcé hexagonal / <i>Reforzado hexagonal</i> / Reforçado hexagonal  <b>SI</b> Renforcé avec pignon intégral / <i>Reforzado con piñón integral</i> / Reforçado com pinhão integrado  <b>UC</b> Mâle cylindrique avec pieds / <i>Macho cilíndrico, con patas</i> / Macho cilíndrico com pé  <b>FS</b> Femelle cannelée / <i>Hembra acanalada</i> / Fêmea com ranhuras  <b>VI</b> Pignon intégral (Double centrage) / <i>Piñón integral (doble centrado)</i> / Pinhão integrado (dupla centragem)  <b>ZI</b> Pignon intégral (Avec bride) / <i>Piñón integral (con brida)</i> / Pinhão integrado (Com flange)</p> <p><b>Numero stadi / Number of stages / Anzahl Stufen</b></p> <p>— Simple étage / <i>Etapa individual</i> / Um estágio  <b>D</b> Double étage / <i>Doble etapa</i> / Duplo estágio  <b>T</b> Triple étage / <i>Triple etapa</i> / Triplo estágio  <b>Q</b> Quadruple étage / <i>Cuádruple etapa</i> / Quadruplo estágio</p> <p><b>Grandezza / Size / Grösse</b>  <b>65, 105, 110, 210, 310, 510, 710, 810, 1010, 1700</b></p> <p><b>Esecuzione</b>  <b>RR</b> Riduttore lineare  <b>RA</b> Riduttore angolare</p>					

Si'il est possible de monter plus d'une grandeur de couple conique à l'entrèe, les différentes alternatives pour les combinaisons possibles sont indiquées par les lettres (A), (B) et (C), à partir de l'alternative avec un couple conique plus petit.  
 Exemple: RA1700 (A), RA1700 (B).

*Si fuese posible montar más de una talla de par cónico en entrada, las diferentes alternativas para las combinaciones resultante se indican con (A), (B) y (C), a partir de la alternativa con par cónico más pequeño.*

*Ejemplo: RA1700 (A), RA1700 (B).*

No caso em que seja possível montar mais do que uma grandeza de par cónico em entrada, as várias alternativas para as combinações que resultam são indicadas com (A), (B) e (C), a partir da alternativa com par cónico mais pequeno.  
 Exemplo: RA1700 (A), RA1700 (B).

## 2.3 Marquage du produit et désignation du type

Sur tous les produits Reggiana Riduttori, une plaquette d'identification est appliquée. Elle est positionnée de manière à être facile à lire, même une fois le réducteur installé.

La figure suivante montre un exemple de la plaquette.

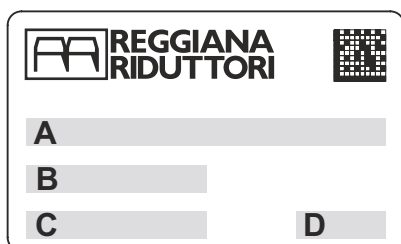

## 2.3 Marcado del producto y denominación del tipo

*Todos los productos Reggiana Riduttori llevan una placa de identificación, colocada de manera que resulte fácilmente legible, también después de la instalación.*

*La siguiente figura presenta un ejemplo de placa.*

## 2.3 Marcação do produto e designação do tipo

Todos os produtos Reggiana Riduttori são munidos de placa de identificação, colocada de modo a ser lida com facilidade, também depois da instalação.

A seguinte figura ilustra um exemplo de placa.

	Légende	Leyenda	Legenda
<b>A</b>	Type de réducteur et rapport de réduction	<i>Tipo de reductor y relación de reducción</i>	Tipo de reductor e relação de redução
<b>B</b>	Code d'identification de la commande	<i>Código identificador de pedido</i>	Código identificativo de encomenda
<b>C</b>	N° progressif de série	<i>N° progresivo de matrícula</i>	N° progressivo de matrícula
<b>D</b>	Mois/année de fabrication	<i>Mes/año de producción</i>	Mês/ano de produção

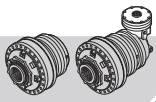

Produttore Manufacturer Hersteller	Oli Idrraulici Hydraulic oils Hydrauliköle			Oli per ingranaggi Gear oils Getriebeöle		
	ISO VG 32	ISO VG 46	ISO VG 68	ISO VG 150	ISO VG 220	ISO VG 320
AGIP	Rocol Foodlube Hi Power 32	-	-	Rocol Foodlube Hi-Torque 150	-	Rocol Foodlube Hi-Torque 320
BP	Enerpar M 32	Enerpar M 46	Enerpar M 68	-	-	-
KLÜBER	Summit Hysyn FG 32	Summit Hysyn FG 46	Summit Hysyn FG 68	Klüberoil 4 UH1 N 150	Klüberoil 4 UH1 N 220	Klüberoil 4 UH1 N 320
MOBIL	DTE FM 32	DTE FM 46	DTE FM 68	DTE FM 150	DTE FM 220	DTE FM 320
SHELL	Cassida Fluid HF 32	Cassida Fluid HF 46	Cassida Fluid HF 68	Cassida Fluid GL 150	Cassida Fluid GL 220	Cassida Fluid GL 320
TEXACO	Cygnus Hydraulic Oil 32	Cygnus Hydraulic Oil 46	Cygnus Hydraulic Oil 68	Cygnus Gear PAO 150	Cygnus Gear PAO 220	-
TOTAL	Nevastane AW 32	Nevastane AW 46	Nevastane AW 68	Nevastane SL 150	Nevastane SL 220	Nevastane SL 320
TRIBOL	Food Proof 1840/32	Food Proof 1840/ 46	Food Proof 1840/68	-	Food Proof 1810/220	Food Proof 1810/320

Nel caso di impiego di altri lubrificanti sintetici, verificarne la compatibilità con le tenute paraolio in NBR presenti nel riduttore.

*If other synthetic lubricants are used always check their compatibility with the NBR oil seals used in the reduction gear.*

Bei Verwendung synthetischer Schmiermittel muss die Kompatibilität mit den im Planetengetriebe montierten Öldichtungen aus NBR geprüft werden.



Non mescolare lubrificanti sintetici di tipo differente.

*Do not mix different kinds of synthetic lubricant together.*

Unterschiedliche Typen von synthetischen Schmiermitteln dürfen nicht gemischt werden.

Se le condizioni di esercizio del riduttore prevedono prolungati periodi di funzionamento tali da produrre una elevata temperatura dell'olio (>60°C) si consiglia l'utilizzo di olio sintetico, per garantire una minore usura dei componenti ed aumentare gli intervalli di sostituzione.

*If the operating conditions of the reduction gear entail prolonged periods of operation such to cause the oil temperature to rise considerably (>60°C) we suggest using a synthetic oil to guarantee less wear of the components and to prolong the intervals between replacing them.*

Wenn die Betriebsbedingungen vom Planetengetriebe längere Betriebszeiten vorsehen, die zu hohen Öltemperaturen führen (>60°C), wird zur Verwendung von synthetischem Öl geraten, das für einen geringeren Verschleiß der Teile und größere Abstände zwischen den Ölwechseln garantiert.

La temperatura massima del lubrificante all'interno del riduttore non deve oltrepassare i 90°C.

*Maximum temperature of the lubricant inside the reduction gear must not go above 90°C.*

Die Temperatur vom Schmiermittel im Planetengetriebe darf 90°C nicht übersteigen.

**6.4 Posizioni di montaggio e disposizione dei tappi**

**6.4 Mounting positions and plugs position**

**6.4 Montageposition und Anordnung der Deckel**

Nelle figure seguenti sono mostrate le possibili posizioni di montaggio, la cui sigla deve essere specificata in fase di ordine del riduttore.

*You can see the possible mounting positions in the figures below. The relative initial must be specified when ordering the reduction gear.*

Die Abbildungen unten zeigen die möglichen Montagepositionen, deren Kürzel bei der Bestellung vom Planetengetriebe angegeben werden muss.

Inoltre sono indicati la disposizione e la tipologia dei tappi ed il livello minimo di lubrificante, come da legenda.

*The layout and type of plugs as well as the minimum lubricant level are also indicated, as per the legend.*

Außerdem sind die Anordnung und der Typ der Deckel sowie der Mindestölstand angegeben (siehe Legende).

**Attenzione:**

Per servizi continuativi (24 h) consigliamo di utilizzare tappi di sfiato con il labirinto e filtro sinterizzato assieme ad una colonnetta.

**Attention!**

*For continuous duty (24h) uses venting plug with labyrinth and filter and a column.*

**Achtung!**

Bei Dauerbetrieb ist es besser auf Säule gebauten Belüftungspfpfen mit synthetischem Filter und Labyrinth einzusetzen.

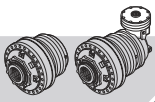

- ① Carico e sfiato  
Filling up and venting  
Füllen und Entlüften
- ② Livello  
Level  
Ölstand
- ③ Scarico  
Drainage  
Ablass
- ④ Sfiato durante il carico  
Venting while filling up  
Entlüften beim Füllen
- Livello minimo  
Minimum level  
Mindestölstand

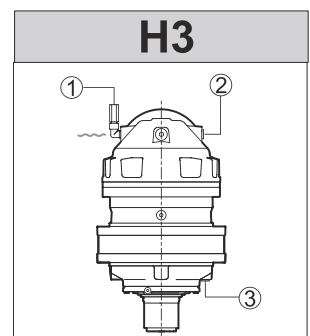
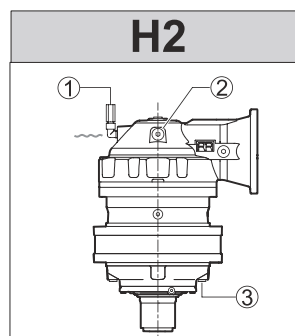
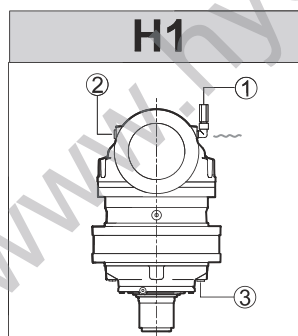
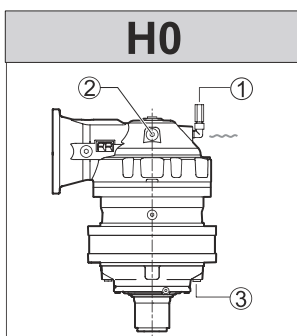
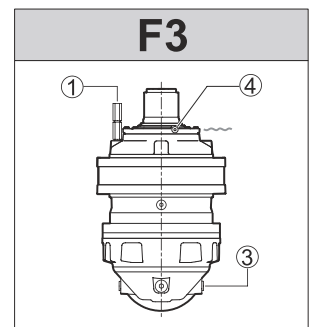
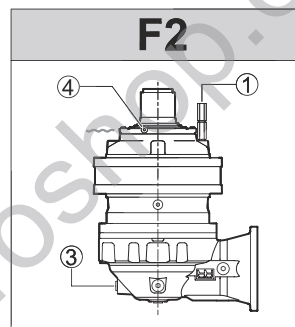
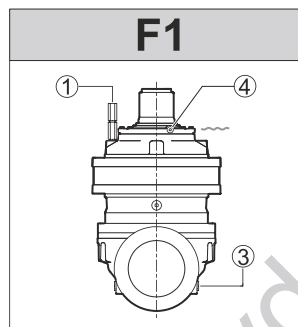
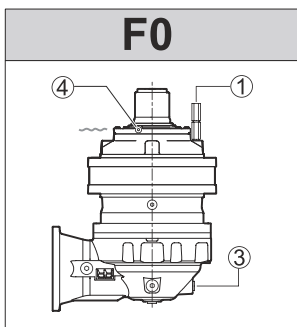
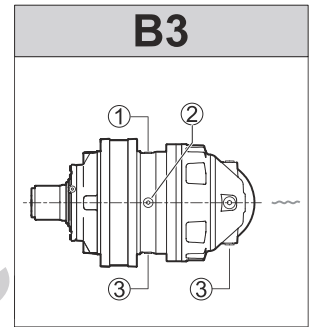
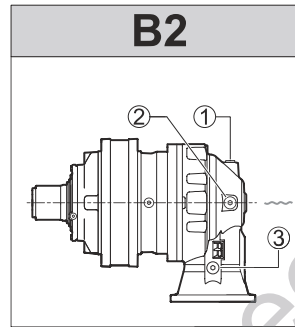
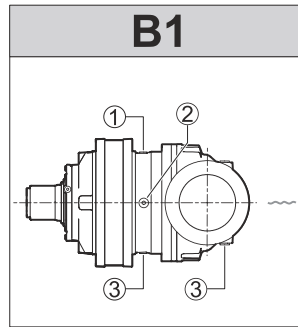
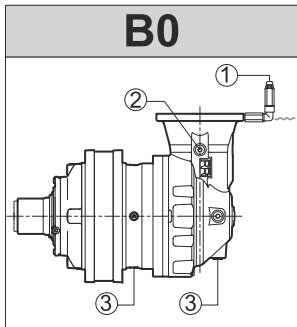
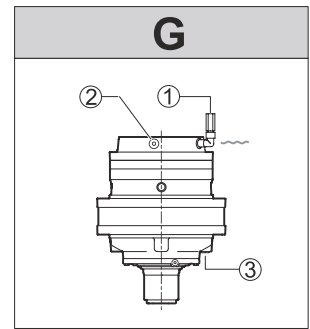
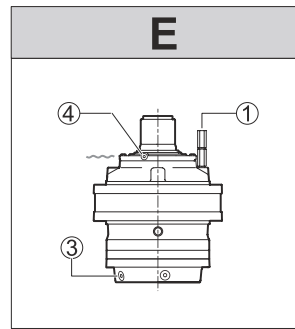
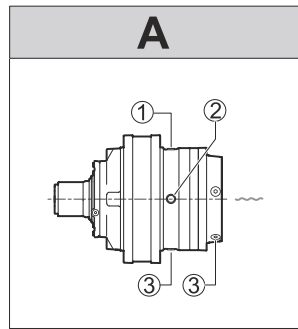

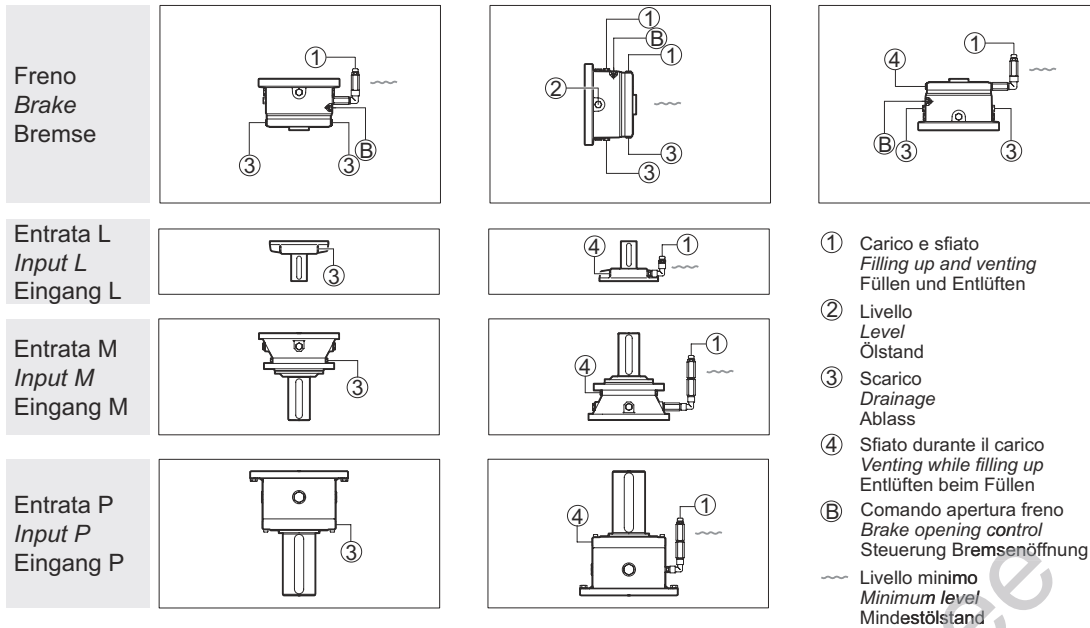
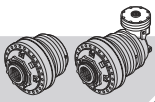

### 6.5 Riempimento

Per le posizioni di montaggio A, B1, B2 e B3 il riempimento va effettuato fino alla mezzeria del riduttore; il corretto livello del lubrificante può essere verificato mediante gli appositi tappi di livello, indicati con (2) nella figura precedente.

Per applicazioni dove la velocità di rotazione in uscita è bassa ( $n_2 \leq 5rpm$ ) consigliamo di riempire 3/4 del volume totale del riduttore di olio.

Se la velocità di rotazione in uscita è molto bassa ( $n_2 \leq 1rpm$ ), o per lunghi periodi di stoccaggio, è consigliabile riempire tutto il riduttore con olio. In questo caso bisogna prevedere l'utilizzo di un vaso d'espansione che consenta l'espansione del volume dell'olio all'aumentare della temperatura.

Per le posizioni di montaggio E, G, B0, F0, F1, F2, F3, H0, H1, H2 e H3, è necessario effettuare il completo riempimento, in modo da consentire la corretta lubrificazione dei componenti posti nella parte più alta del riduttore. In questo caso durante il riempimento occorre rimuovere almeno uno dei tappi posti nella parte più alta del riduttore, indicati con (4) nella figura precedente, in modo da evitare la formazione di bolle d'aria.

### 6.5 Filling up

For the assembly positions A, B1, B2 and B3 fill up to the halfway point of the reduction gear; the right level of the lubricant can be checked with the level plugs, indicated with (2) in the previous figure.

For applications with low output rotation speeds ( $n_2 \leq 5rpm$ ) we advise you to fill the reduction gear with oil to 3/4 of the total volume.

For very low output rotation speeds ( $n_2 \leq 1rpm$ ) or when storing for long periods of time, fill the reduction gear completely with oil. In this case, use an expansion tank to allow the oil volume to increase according to temperature.

For the assembly positions E, G, B0, F0, F1, F2, F3, H0, H1, H2 and H3, they have to be filled right up to the top to allow correct lubrication of the components situated at the upper most part of the reduction gear. In this case, when filling up, you have to remove at least one of the plugs from the upper most part of the reduction gear, indicated with (4) in the previous figure, so as to prevent air bubbles forming.

### 6.5 Einfüllen vom Öl

Bei den Montagepositionen A, B1, B2 und B3 erfolgt das Einfüllen bis zur Mittellinie vom Planetengetriebe. Der korrekte Ölstand kann über die dafür vorgesehenen Ölstandsdeckel kontrolliert werden (siehe Abbildung oben (2)).

Für Anwendungen, bei denen die Rotationsgeschwindigkeit im Ausgang niedrig ist ( $n_2 \leq 5UpM$ ), empfehlen wir, das Getriebe bis zu einem 3/4 des Gesamtvolumens mit Öl zu füllen. Wenn die Rotationsgeschwindigkeit im Ausgang sehr niedrig ist ( $n_2 \leq 1UpM$ ) oder für lange Lagerzeiten, ist es ratsam, das gesamte Getriebe mit Öl zu füllen. In diesem Fall, muss die Verwendung eines Ausdehnungsgefäßes vorgesehen werden, das die Ausdehnung des Ölvolumens bei Erhöhung der Temperatur gestattet.

Bei den Montagepositionen E, G, B0, F0, F1, F2, F3, H0, H1, H2 und H3 ist eine komplette Füllung erforderlich, um die korrekte Schmierung der Teile an der höchsten Stelle im Planetengetriebe zu garantieren. In diesem Fall muss beim Einfüllen mindestens einer der Deckel oben (Abbildung oben (4)) abgenommen werden, damit sich keine Luftblasen bilden.



# 710

IT EN DE FR ES PT

RR710 .. **i**



	i	T <sub>2</sub> [Nm]						n <sub>1max</sub> [min <sup>-1</sup> ]	T <sub>2max</sub> [Nm]	P <sub>t</sub> [kW]
		n <sub>2</sub> x h								
1/...		10000 (10 <sup>4</sup> )	25000 (2.5 · 10 <sup>4</sup> )	50000 (5 · 10 <sup>4</sup> )	100000 (10 <sup>5</sup> )	500000 (5 · 10 <sup>5</sup> )	1000000 (10 <sup>6</sup> )			
<b>RR710</b>	<b>4.00</b>	7320	6170	5420	4810	4360	3980	3500	8500 (M.../FS) 9300 (S...)	21
	<b>5.20</b>	5070	4260	3740	3460	3130	3000			
	<b>6.25</b>	4400	3710	3260	3100	2810	2690			
<b>RR710D</b>	<b>16.00</b>	7320	6170	5420	4810	4360	3980	3500	8500 (M.../FS) 9300 (S...)	13
	<b>23.20</b>	7320	6170	5420	4810	4360	3980			
	<b>28.00</b>	6050	5610	5380	4810	4360	3980			
	<b>36.25</b>	4400	3710	3260	3100	2810	2690			
	<b>43.75</b>	4400	3710	3260	3100	2810	2690			
<b>RR710T</b>	<b>51.36</b>	7320	6170	5420	4810	4360	3980	3500	8500 (M.../FS) 9300 (S...)	10
	<b>65.60</b>	7320	6170	5420	4810	4360	3980			
	<b>74.47</b>	7320	6170	5420	4810	4360	3980			
	<b>95.12</b>	7320	6170	5420	4810	4360	3980			
	<b>115.2</b>	7320	6170	5420	4810	4360	3980			
	<b>151.76</b>	6050	5610	5380	4810	4360	3980			
	<b>201.6</b>	6050	5610	5380	4810	4360	3980			
	<b>261.00</b>	4400	3710	3260	3100	2810	2690			
	<b>315.00</b>	4400	3710	3260	3100	2810	2690			
	<b>RR710Q</b>	<b>346.29</b>	7320	6170	5420	4810	4360			
<b>407.38</b>		7320	6170	5420	4810	4360	3980			
<b>442.31</b>		7320	6170	5420	4810	4360	3980			
<b>535.68</b>		7320	6170	5420	4810	4360	3980			
<b>590.70</b>		7320	6170	5420	4810	4360	3980			
<b>715.39</b>		7320	6170	5420	4810	4360	3980			
<b>937.44</b>		6050	5610	5380	4810	4360	3980			
<b>1251.94</b>		6050	5610	5380	4810	4360	3980			
<b>1464.75</b>		4400	3710	3260	3100	2810	2690			
<b>1620.81</b>		4400	3710	3260	3100	2810	2690			
<b>1956.15</b>		4400	3710	3260	3100	2810	2690			



RA710 .. **i**



i	T <sub>2</sub> [Nm]						n <sub>1max</sub> [min <sup>-1</sup> ]	T <sub>2max</sub> [Nm]	P <sub>t</sub> [kW]	
	n <sub>2</sub> x h									
1/...	10000 (10 <sup>4</sup> )	25000 (2.5 · 10 <sup>4</sup> )	50000 (5 · 10 <sup>4</sup> )	100000 (10 <sup>5</sup> )	500000 (5 · 10 <sup>5</sup> )	1000000 (10 <sup>6</sup> )				
<b>RA710</b>	<b>16.00</b>	6680	6050	5340	4810	3870	3140	3500	8500 (M.../FS) 9300 (S...)	23
	<b>20.80</b>	5070	4260	3740	3460	3130	3000			
	<b>25.00</b>	4400	3710	3260	3100	2810	2690			
<b>RA710D</b>	<b>51.52</b>	6910	6110	5420	4810	3640	2960	3500	8500 (M.../FS) 9300 (S...)	14
	<b>74.70</b>	7320	6170	5420	4810	4360	3840			
	<b>90.16</b>	6050	5610	5380	4810	4360	3980			
	<b>116.73</b>	4400	3710	3260	3100	2810	2690			
	<b>140.88</b>	4400	3710	3260	3100	2810	2690			
	<b>164.86</b>	4210	3900	3690	3490	3060	2890			
	<b>177.58</b>	4500	4180	3740	3460	3130	3000			
	<b>184.00</b>	4400	3710	3260	3100	2810	2690			
	<b>214.32</b>	5070	4260	3740	3460	3130	3000			
	<b>257.60</b>	4400	3710	3260	3100	2810	2690			
<b>RA710T</b>	<b>165.38</b>	7320	6170	5420	4810	4360	3980	3500	8500 (M.../FS) 9300 (S...)	11
	<b>211.23</b>	7320	6170	5420	4810	4360	3980			
	<b>239.80</b>	7320	6170	5420	4810	4360	3980			
	<b>306.29</b>	7320	6170	5420	4810	4360	3980			
	<b>370.94</b>	7320	6170	5420	4810	4360	3980			
	<b>488.67</b>	6050	5610	5380	4810	4360	3980			
	<b>649.15</b>	6050	5610	5380	4810	4360	3980			
	<b>840.42</b>	4400	3710	3260	3100	2810	2690			
	<b>1014.30</b>	4400	3710	3260	3100	2810	2690			
	<b>1187.02</b>	6050	5610	5380	4810	4360	3980			
	<b>1278.59</b>	5070	4260	3740	3460	3130	3000			
	<b>1396.19</b>	4400	3710	3260	3100	2810	2690			
	<b>1543.13</b>	5070	4260	3740	3460	3130	3000			
	<b>1854.72</b>	4400	3710	3260	3100	2810	2690			

www.hydroshop.be



# 710

IT EN DE FR ES PT

RR710 .. i ..

I

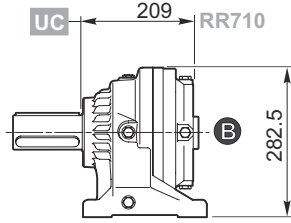
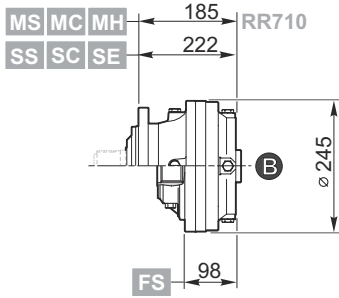

D

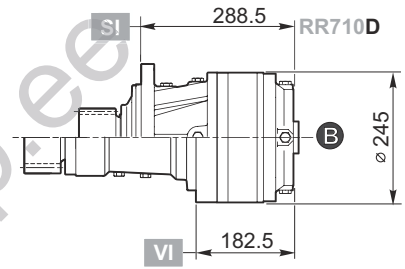
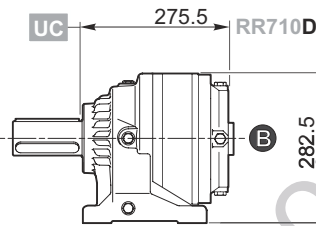
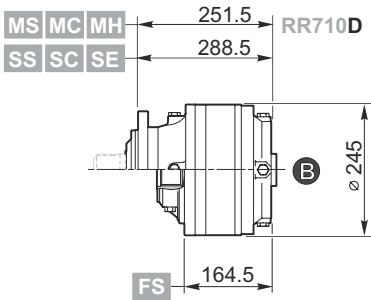

T

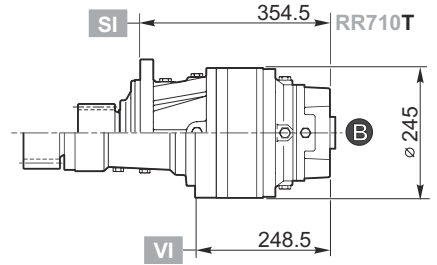
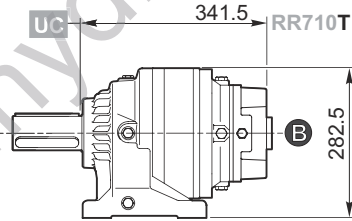
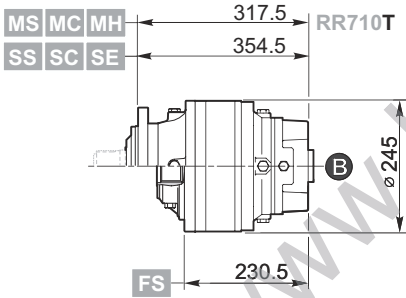

Q

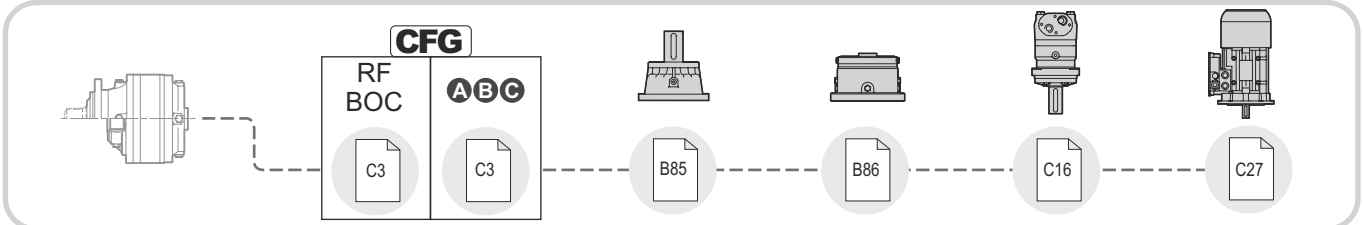
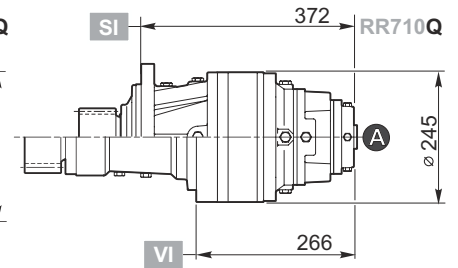
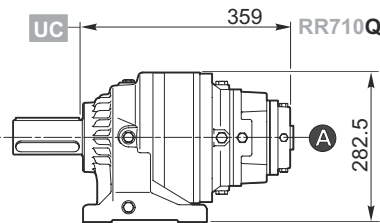
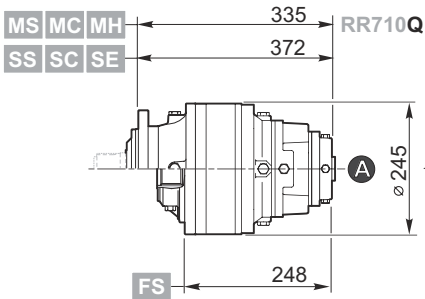



RA710 .. i ..

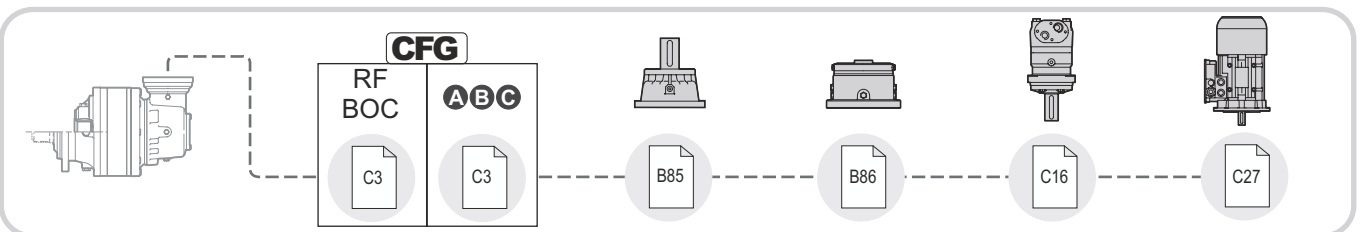
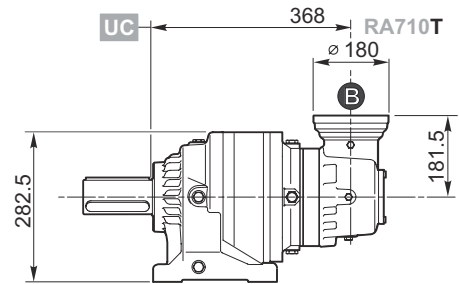
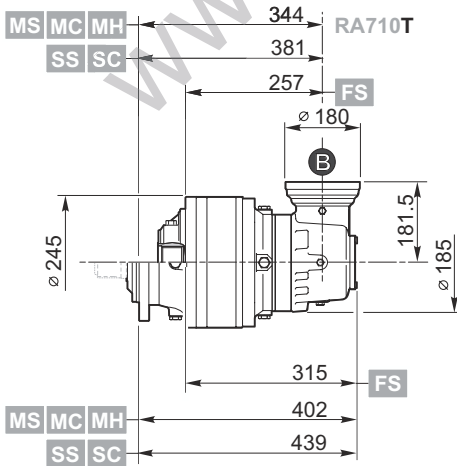
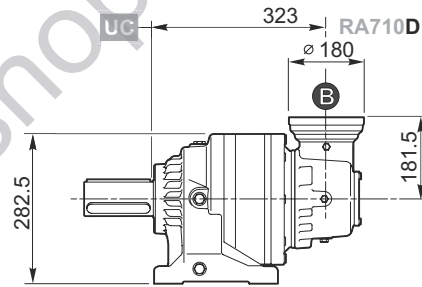
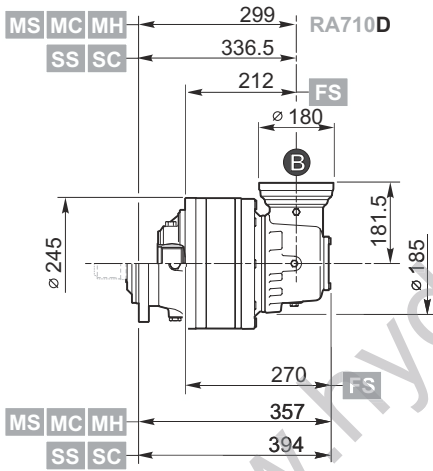
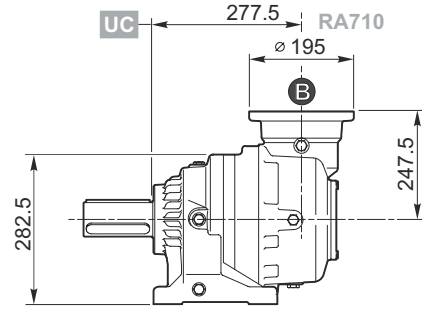
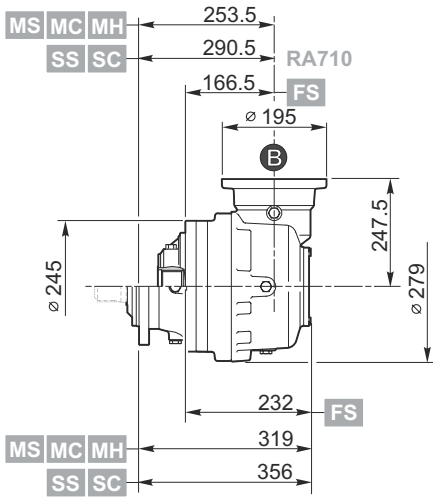

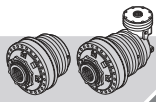

# 710

IT EN DE FR ES PT

RR710  
RA710

MS

MC

MH

SS

SC

SE

UC

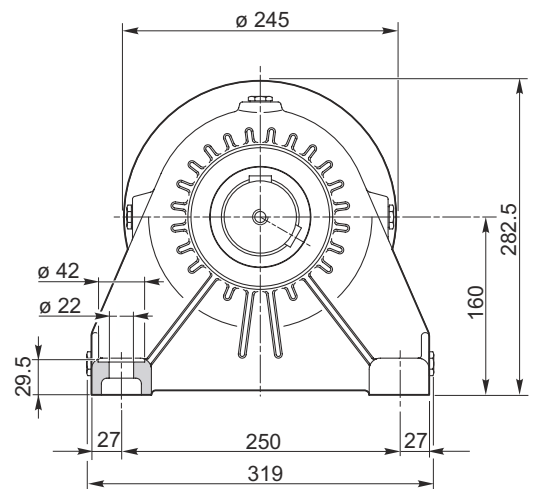
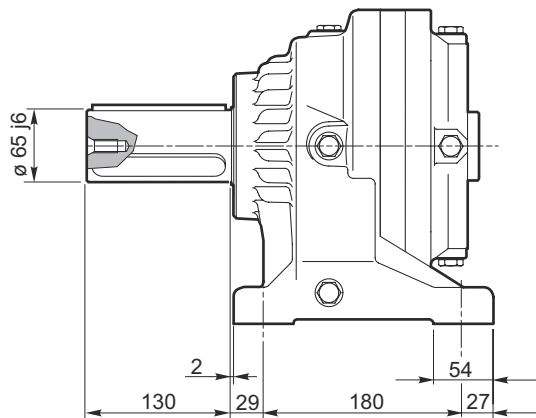
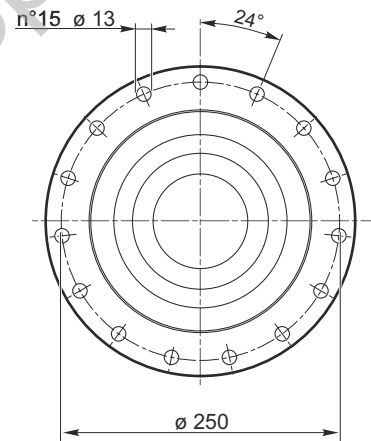
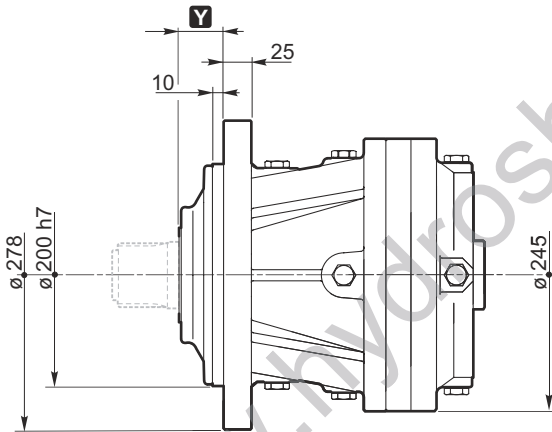
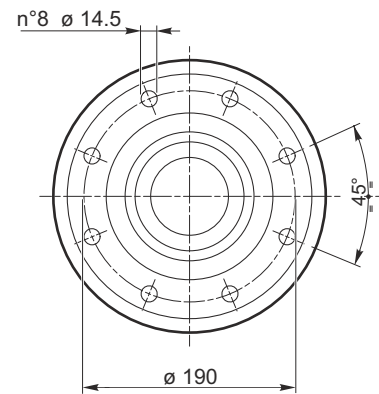
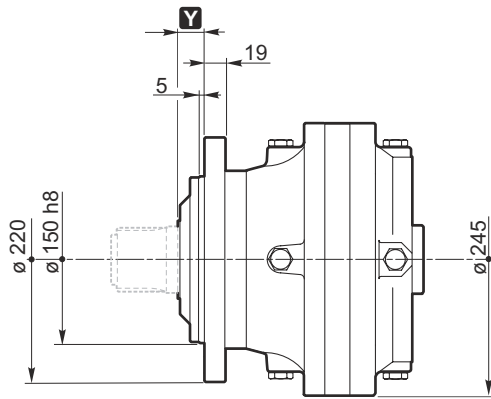

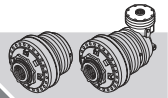

**MS**

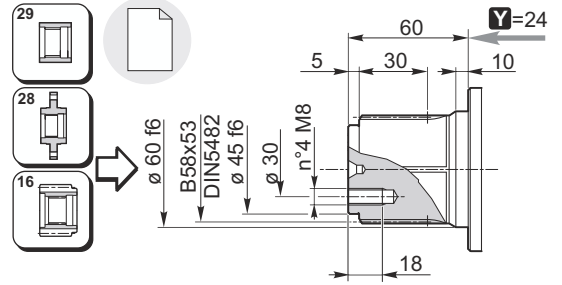
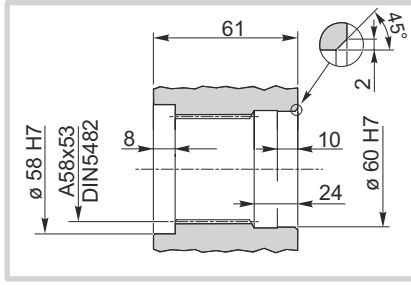
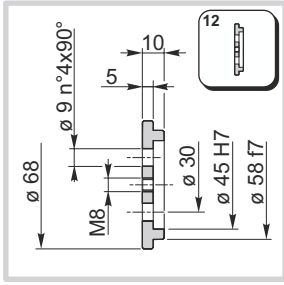

**SS**

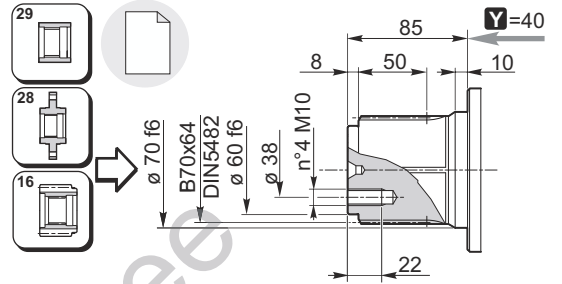
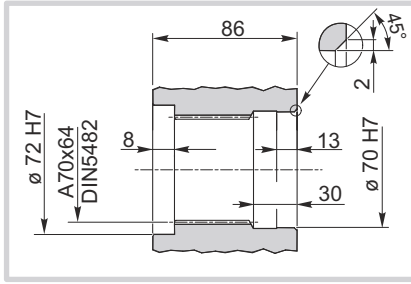
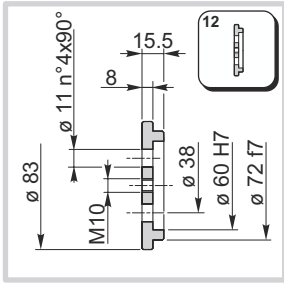

**MC**  
**SC**  
**UC**

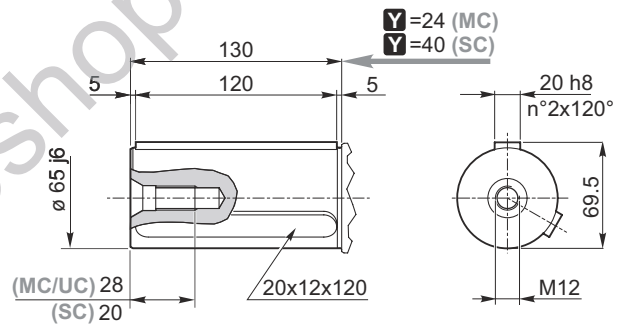
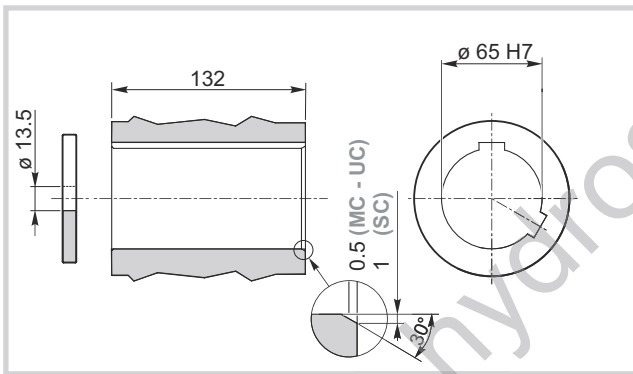

**MH**

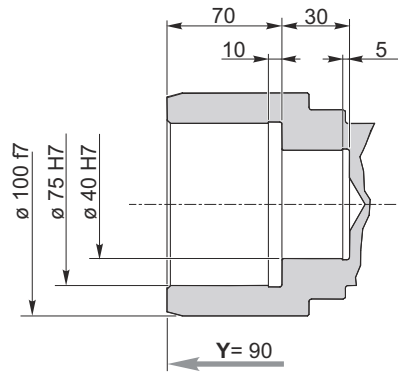
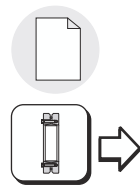
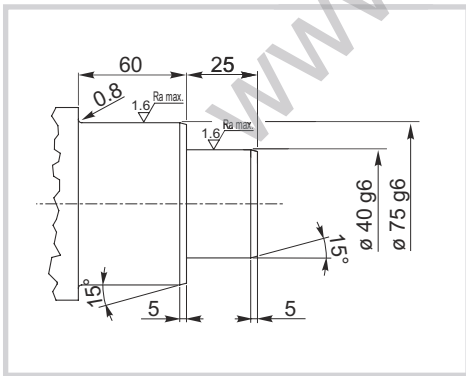

**SE**

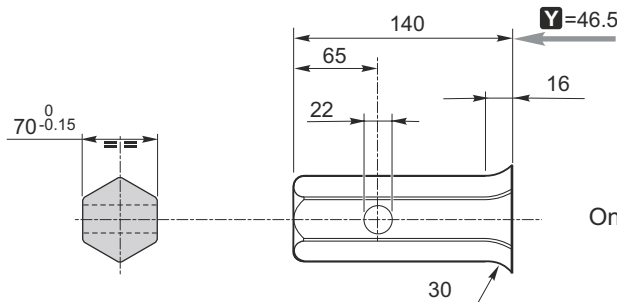

Only for RR710

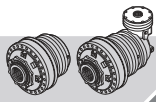

# 710

IT EN DE FR ES PT

RR710 .. i ..

SI

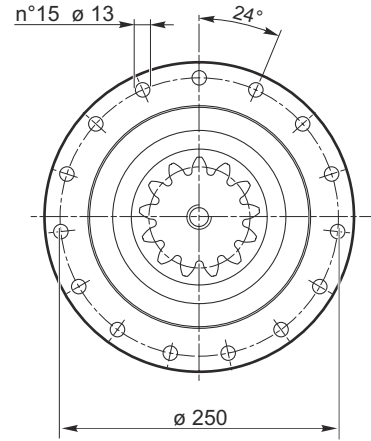
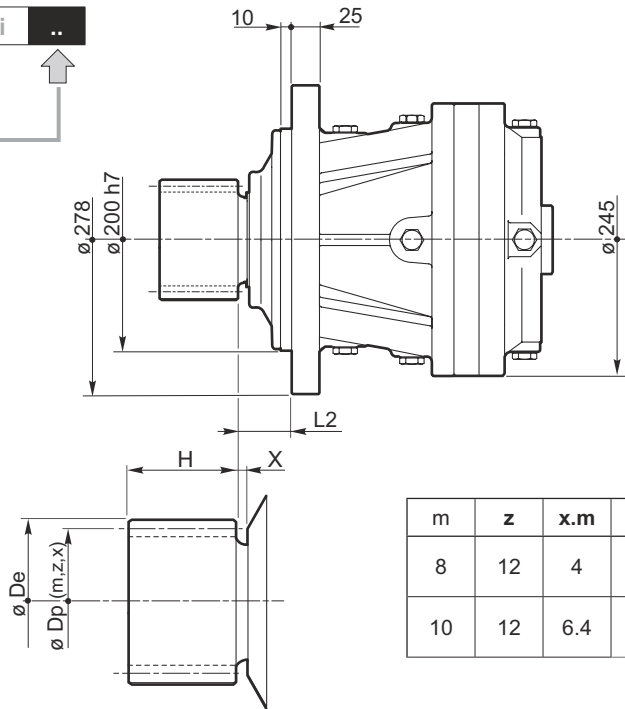

m	z	x.m	H	Dp	De	L2	X	code	
8	12	4	70	96	118	45	7	03-095	154F3333
10	12	6.4	80	120	149	44	6	03-236	154B3948

VI

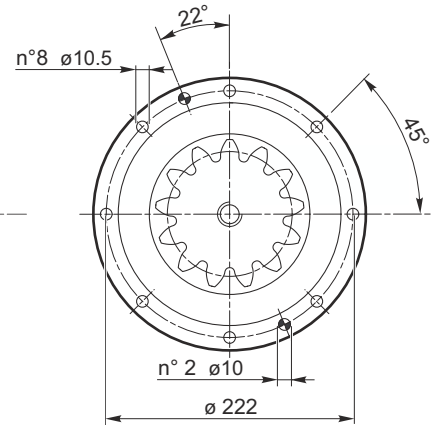
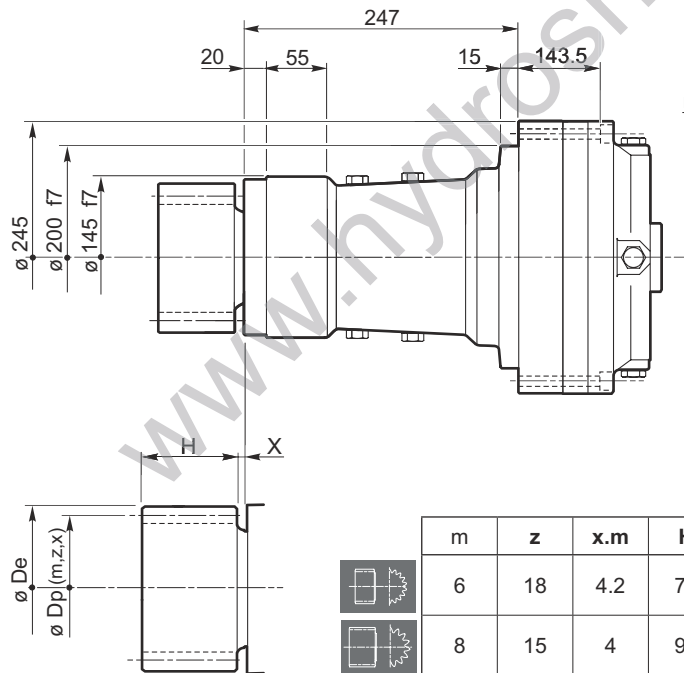

m	z	x.m	H	Dp	De	X	code	
6	18	4.2	70	108	126	3	03-472	154F1663
8	15	4	95	120	144	3	03-310	154B2443
8	15	5	85	120	144.5	3	03-365	154B4171
8	11	3	73	88	110	8	03-284	154-5637
10	11	5	80	110	135	3	03-402	154F3597
10	11	3.75	77	110	135	4	03-292	154B1799
10	12	3.2	78	120	143.8	3	03-237	154-5629



RR710	..	i	<b>FS</b>
RA710			

**FS**

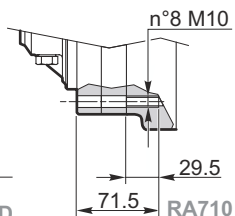
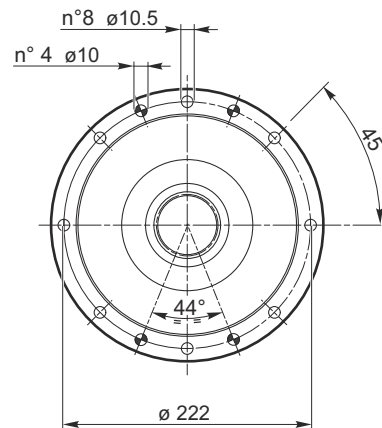
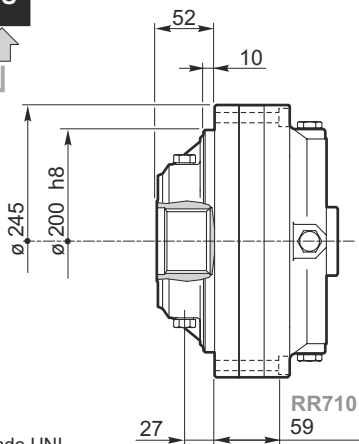

**Trattamento termico:**  
Tempra ad induzione secondo UNI 10932 su scanalato interno

**Heat treatment:**  
Induction hardening according to UNI 10932 on internal spline

**Wärmebehandlung:**  
Induktionshärtung nach UNI 10932 an interner Nut

**Traitement thermique :**  
Trempe par induction conformément à la norme UNI 10932 sur cannelé interne

**Tratamiento térmico:**  
Temple por inducción según UNI 10932 en acanalado interno

**Tratamento térmico:**  
Tempera por indução segundo UNI 10932 sobre ranhuras internas

RR710  
59  
125.5  
RR710D RA710D  
RR710T RA710T  
RR710Q

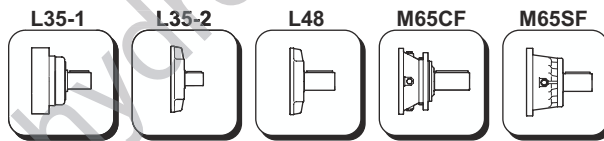
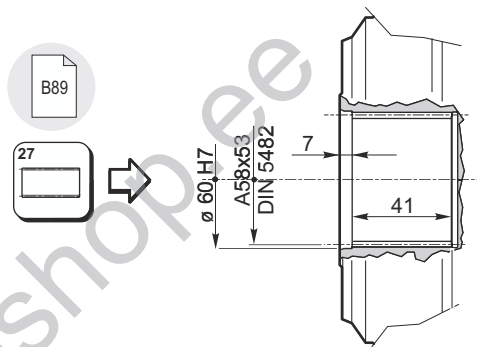
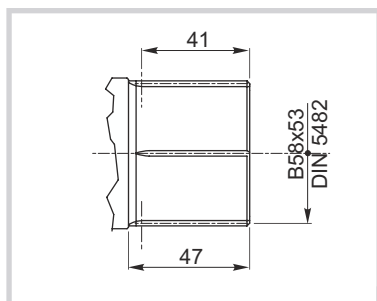

C10

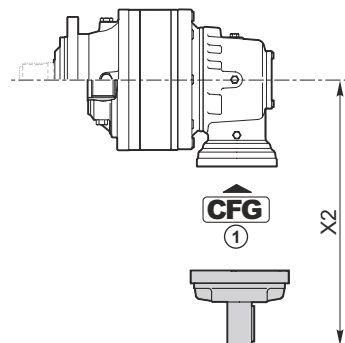
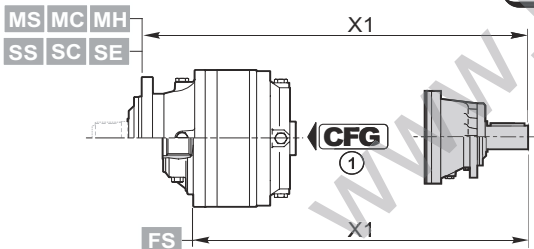

	<b>CFG</b> ①		code	X1
RR710	RF	<b>M65SF</b>	154B4249	369.5 (M..) 282.5 (FS) 406.5 (S..)
	RF	<b>M65CF</b>	154-2407	392 (M..) 305 (FS) 429 (S..)
	BOC	<b>L48</b>	154B3989	306.5 (M..) 219.5 (FS) 343.5 (S..)
RR710D	RF	<b>M65SF</b>	154B4249	436 (M..) 349 (FS) 473 (S..)
	RF	<b>M65CF</b>	154-2407	459 (M..) 372 (FS) 496 (S..)
	BOC	<b>L48</b>	154B3989	373 (M..) 286 (FS) 410 (S..)
RR710T	BOC	<b>L35-2</b>	154-2190M1	407 (M..) 320 (FS) 444 (S..)
RR710Q	RF	<b>L35-1</b>	154B4054	423 (M..) 336 (FS) 460 (S..)

	<b>CFG</b> ①		code	X2
RA710	BOC	<b>L48</b>	154B3989	347.5
RA710D	BOC	<b>L35-2</b>	154-2190M1	270.5
RA710T	BOC	<b>L35-2</b>	154-2190M1	270.5

<b>CFG</b>	
RF	C3
BOC	C3
<b>A</b>	
<b>B</b>	
<b>C</b>	

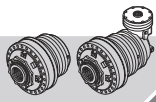

# 710

IT EN DE FR ES PT

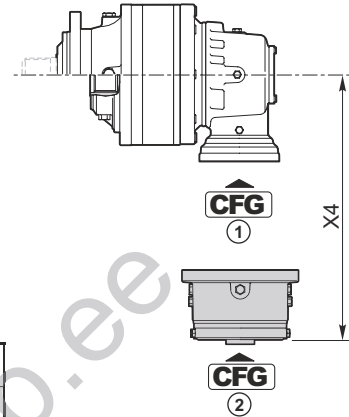
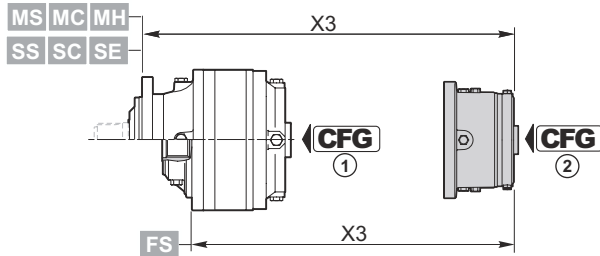
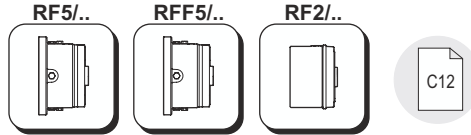

<b>CFG</b>	
RF	C3
BOC	
<b>A</b>	C3
<b>B</b>	
<b>C</b>	

RF5/..	CFG ①	T <sub>f</sub> [Nm]	CFG ②							
			B			OMTS 12/24 z16	OMVS 10/20 z16			
			code	X3	X4	code	code	X3	X4	
RR710	RF	210	154-2872	275.5 (M...) 188.5 (FS) 312.5 (S...)	—		154-2879	154-2886	279.2 (M...) 192.2 (FS) 316.2 (S...)	—
		290	154-2873				154-2880	154-2887		
		430	154-2874				154-2881	154-2888		
		650	154-2875				154-2882	154-2889		
		850	154-2876				154-2883	154-2890		
		1100	154-2877				154-2884	154-2891		
RR710D	RF	210	154-2872	342 (M...) 255 (FS) 379 (S...)	—		154-2879	154-2886	345.7 (M...) 258.7 (FS) 382.7 (S...)	—
		290	154-2873				154-2880	154-2887		
		430	154-2874				154-2881	154-2888		
		650	154-2875				154-2882	154-2889		
		850	154-2876				154-2883	154-2890		
		1100	154-2877				154-2884	154-2891		
		1300	154-2878			154-2885	154-2892			

RFF5/..	CFG ①	T <sub>f</sub> [Nm]	CFG ②							
			B			OMTS 12/24 z16	OMVS 10/20 z16			
			code	X3	X4	code	code	X3	X4	
RA710	RF	210	154-2893	—	316.6		154-5338	154-5345	—	320.5
		290	154-2894				154-5339	154-5346		
		430	154-2895				154-5340	154-5347		
		650	154-2896				154-5341	154-5348		
		850	154-2897				154-5342	154-5349		
		1100	154-2898				154-5343	154-5350		
		1300	154-2899				154-5344	154-5351		



RF2/..	CFG ①	T <sub>f</sub> [Nm]	CFG ②						
			B		OMP/OMR SAE A 2B Ø 25	OMP/OMR SAE A 2B 1" 6B	OMP/OMR SAE A 4B Ø 25	OMP/OMR SAE A 4B 1" 6B	X3
			code	X3	code	code	code	code	
RR710D	RF	70	154-2345	314.5 (M...) 227.5 (FS) 351.5 (S...)	154-2345M10	154-2345M11	154-2345M16	154-2345M17	304.5 (M...) 217.5 (FS) 341.5 (S...)
		140	154-2346		154-2346M10	154-2346M11	154-2346M16	154-2346M17	
		210	154-2347		154-2347M10	154-2347M11	154-2347M16	154-2347M17	
		320	154-2348		154-2348M10	154-2348M11	154-2348M16	154-2348M17	
		430	154-2349		154-2349M10	154-2349M11	154-2349M16	154-2349M17	
		600	154B9186		154B9186M10	154B9186M11	154B9186M16	154B9186M17	
RR710T	RF	70	154-2838M1	356 (M...) 269 (FS) 393 (S...)	154-2863	154-2863M11	154-2635	154-2635M11	346 (M...) 259 (FS) 383 (S...)
		140	154-2839M1		154-2864	154-2864M11	154-2636	154-2636M11	
		210	154-2840M1		154-2865	154-2865M11	154-2637	154-2637M11	
		320	154-2841M1		154-2866	154-2866M11	154-2638	154-2638M11	
		430	154-2842M1		154-2867	154-2867M11	154-2639	154-2639M11	
		600	154B8962M1		154B9665	154B9665M11	154B9666	154B9666M11	

	CFG ①	T <sub>f</sub> [Nm]	CFG ②						
			A		OMP/OMR SAE A 2B Ø 25	OMP/OMR SAE A 2B 1" 6B	OMP/OMR SAE A 4B Ø 25	OMP/OMR SAE A 4B 1" 6B	X3
			code	X3	code	code	code	code	
RR710Q	RF	70	154-2832M1	401 (M...) 314 (FS) 438 (S...)	154-2858M1	154-2858M5			396.5 (M...) 309.5 (FS) 433.5 (S...)
		140	154-2833M1		154-2859M1	154-2859M5			
		210	154-2834M1		154-2860M1	154-2860M5			
		320	154-2836M1		154-2861M1	154-2861M5			
		430	154-2837M1		154-2862M1	154-2862M5			
		600	154B8959M1		154B9663M1	154B9663M5			

	CFG ①	T <sub>f</sub> [Nm]	CFG ②						
			B		OMP/OMR SAE A 2B Ø 25	OMP/OMR SAE A 2B 1" 6B	OMP/OMR SAE A 4B Ø 25	OMP/OMR SAE A 4B 1" 6B	X4
			code	X4	code	code	code	code	
RA710	RF	70	154F2991	285.3					
		140	154F1890						
		210	154F2961						
		320	154B3591						
		430	154B3592						
		600	154F2992						
RA710D	RF	70	154-2838M12	223.8	154-2863M12	154-2863M13	154-2635M12		213.8
		140	154-2839M12		154-2864M12	154-2864M13	154-2636M12		
		210	154-2840M12		154-2865M12	154-2865M13	154-2637M12		
		320	154-2841M12		154-2866M12	154-2866M13	154-2638M12		
		430	154-2842M12		154-2867M12	154-2867M13	154-2639M12		
		600	154B8962M12		154B9665M12	154B9665M13	154B9666M12		
RA710T	RF	70	154-2838M12	223.8	154-2863M12	154-2863M13	154-2635M12		213.8
		140	154-2839M12		154-2864M12	154-2864M13	154-2636M12		
		210	154-2840M12		154-2865M12	154-2865M13	154-2637M12		
		320	154-2841M12		154-2866M12	154-2866M13	154-2638M12		
		430	154-2842M12		154-2867M12	154-2867M13	154-2639M12		
		600	154B8962M12		154B9665M12	154B9665M13	154B9666M12		

**CFG**

RF  
BOC C3

**A**  
**B**  
**C** C3

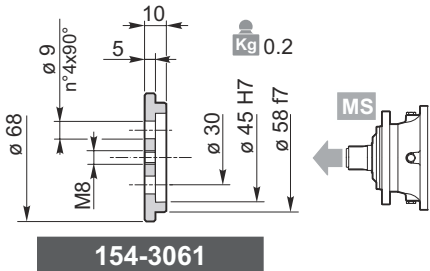
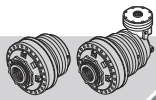

**154-3061**

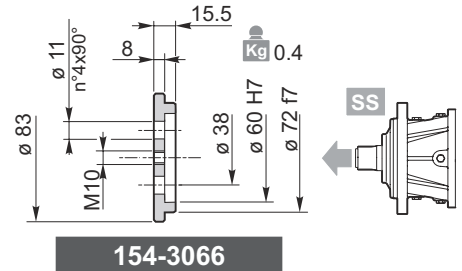

**154-3066**

Materiale / Material / Material / Matériau / Material / Material:  
 Acciaio / Steel / Stahl / Acier / Acero / Aço  
 C40 EN 10083-1 (1.1186)

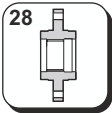

**154-3086**

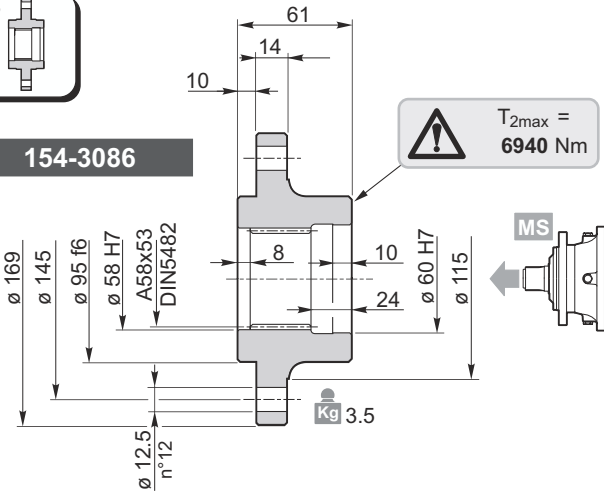

**154-3087**

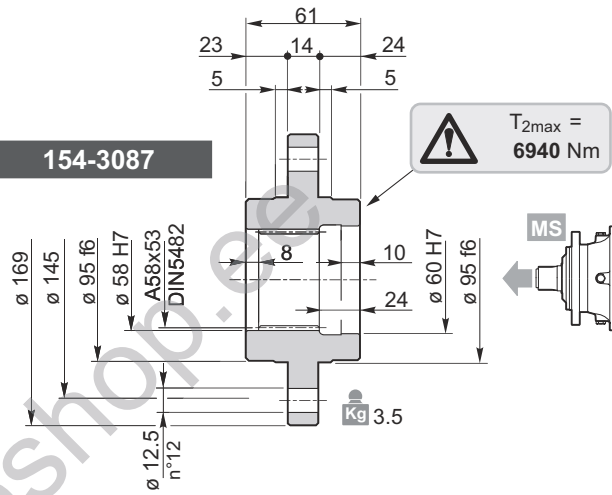

Materiale / Material / Material / Matériau / Material / Material:  
 Acciaio / Steel / Stahl / Acier / Acero / Aço EN 10083-1-C40 (1.1186)

**Trattamento termico:**  
 Tempra ad induzione secondo UNI 10932 su scanalato interno  
**Heat treatment:**  
 Induction hardening according to UNI 10932 on internal spline  
**Wärmebehandlung:**  
 Induktionshärtung nach UNI 10932 an interner Nut  
**Traitement thermique:**  
 Trempe par induction conformément à la norme UNI 10932 sur cannelé interne  
**Tratamiento térmico:**  
 Temple por inducción según UNI 10932 en acanalado interno  
**Tratamento térmico:**  
 Tempera por indução segundo UNI 10932 sobre ranhuras internas

**154-3114**

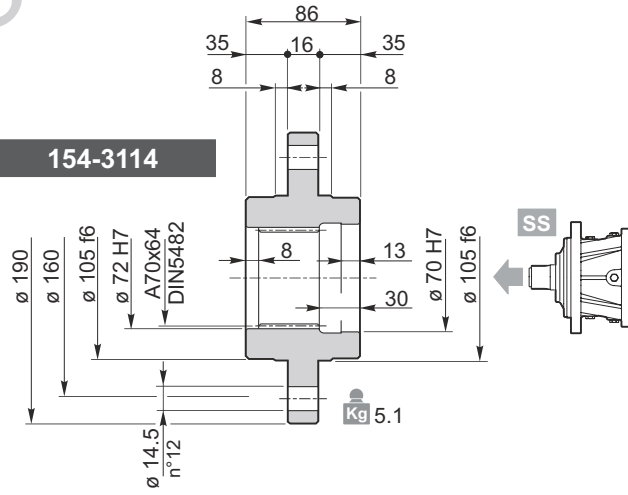

**154-3091**

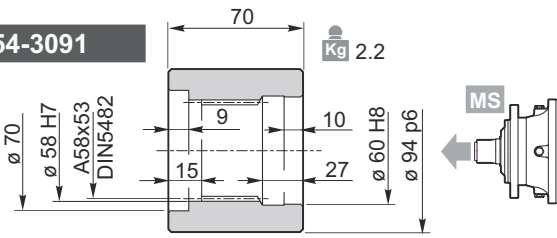

**154-3090**

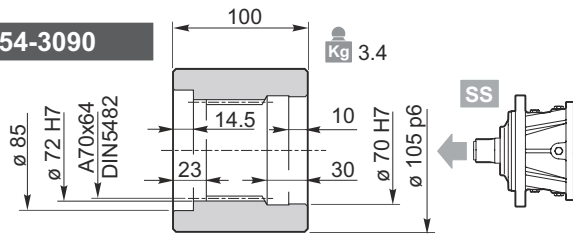

Materiale / Material / Material / Matériau / Material / Material: **Acciaio / Steel / Stahl / Acier / Acero / Aço 39NiCrMo3 UNI 7845 (1.6511)**

**Trattamento termico:**  
 Tempra ad induzione secondo UNI 10932 su scanalato interno  
**Heat treatment:**  
 Induction hardening according to UNI 10932 on internal spline  
**Wärmebehandlung:**  
 Induktionshärtung nach UNI 10932 an interner Nut

**Traitement thermique:**  
 Trempe par induction conformément à la norme UNI 10932 sur cannelé interne  
**Tratamiento térmico:**  
 Temple por inducción según UNI 10932 en acanalado interno  
**Tratamento térmico:**  
 Tempera por indução segundo UNI 10932 sobre ranhuras internas

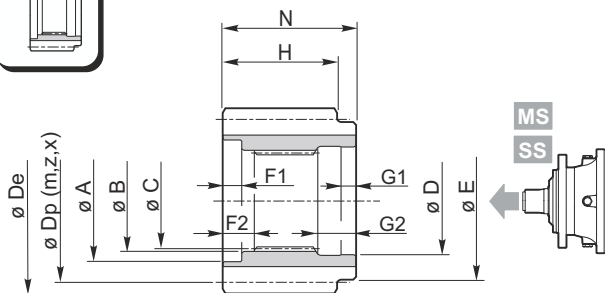

Materiale / Material / Material  
 Matériau / Material / Material  
 Acciaio / Steel / Stahl / Acier / Acero / Aço  
 39NiCrMo3 UNI 7845 (1.6511)

Trattamento termico:  
 Tempra ad induzione secondo UNI 10932 su scanalato interno

Heat treatment:  
 Induction hardening according to UNI 10932 on internal spline

Wärmebehandlung:  
 Induktionshärtung nach UNI 10932 an interner Nut

Traitement thermique:  
 Trempe par induction conformément à la norme UNI 10932 sur cannelé interne

Tratamiento térmico:  
 Temple por inducción según UNI 10932 en acanalado interno

Tratamento térmico:  
 Tempera por indução segundo UNI 10932 sobre ranhuras internas

	A	B	C	D	E	F1	F2	G1	G2	N	m	z	x	H	Dp	De	Code
MS	70	58 H7	DIN5482 A58x53	60 H7	72	7	13	12	27	68	4.5	18	0.4444	65	81	93	154-3106
	70	58 H7	DIN5482 A58x53	60 H7	68	7	13	10	27	68	5	17	0.4	65	85	98	154-2287
	70	58 H7	DIN5482 A58x53	60 H7	68	7	13	10	27	68	5	19	0	65	95	104	154-2286
	70	58 H7	DIN5482 A58x53	60 H7	75	7	13	12	27	68	6	14	0.5	65	84	101.5	154-3082
	70	58 H7	DIN5482 A58x53	60 H7	68	7	13	10	27	68	6	15	0.25	65	90	103	154-3107
	70	58 H7	DIN5482 A58x53	60 H7	68	7	13	10	27	68	6	16	0.25	65	96	109	154-3245
	70	58 H7	DIN5482 A58x53	60 H7	78	7	13	12	27	68	8	12	0.5	65	96	118	154-3074
	70	58 H7	DIN5482 A58x53	60 H7	68	7	13	10	27	68	8	14	0	65	112	126	154-3250
	70	58 H7	DIN5482 A58x53	60 H7	78	7	13	12	27	68	8	15	0	65	120	136	154-3246
	70	58 H7	DIN5482 A58x53	60 H7	68	7	13	10	27	68	8	15	0.25	65	120	138	154-3235
	70	58 H7	DIN5482 A58x53	60 H7	78	7	13	12	27	68	8	18	0	65	144	158	154-3103
	70	58 H7	DIN5482 A58x53	60 H7	78	7	13	12	27	68	10	10	0.25	65	100	124.5	154-3075
	70	58 H7	DIN5482 A58x53	60 H7	78	7	13	12	27	68	10	12	0.475	65	120	149.5	154-3105
	70	58 H7	DIN5482 A58x53	60 H7	68	7	13	10	27	68	10	15	0	65	150	167	154-3248
SS	85	72 H7	DIN5482 A70x64	70 H7	90	7.5	16	10	30	93	8	17	0	85	136	149.5	154-2290
	85	72 H7	DIN5482 A70x64	70 H7	90	7.5	16	10	30	93	10	13	0.4	85	130	157	154-3249
	85	72 H7	DIN5482 A70x64	70 H7	90	7.5	16	10	30	93	10	14	0	85	140	156	154-3247
	85	72 H7	DIN5482 A70x64	70 H7	90	7.5	16	10	30	93	10	15	0.7	85	150	179	154-2291

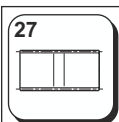

**Kg 3.3**

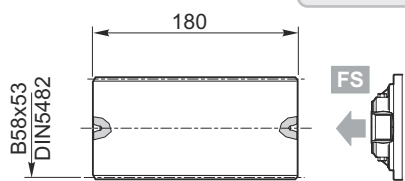

**154-3052**

Materiale / Material / Material  
 Matériau / Material / Material:  
 Acciaio / Steel / Stahl / Acier / Acero / Aço  
 39NiCrMo3 UNI 7845 (1.6511)

**T<sub>2max</sub> = 8100 Nm**

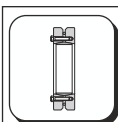

**Kg 4.7**

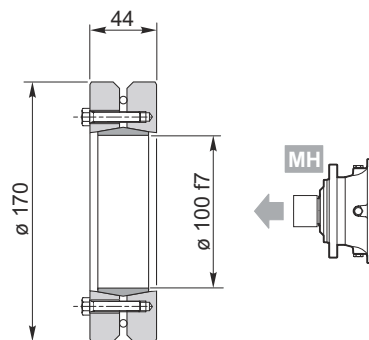

**154B3090**

C36

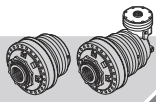

# 710

IT EN DE FR ES PT

RR	710	..	<b>MS</b>
RA			<b>MC</b>

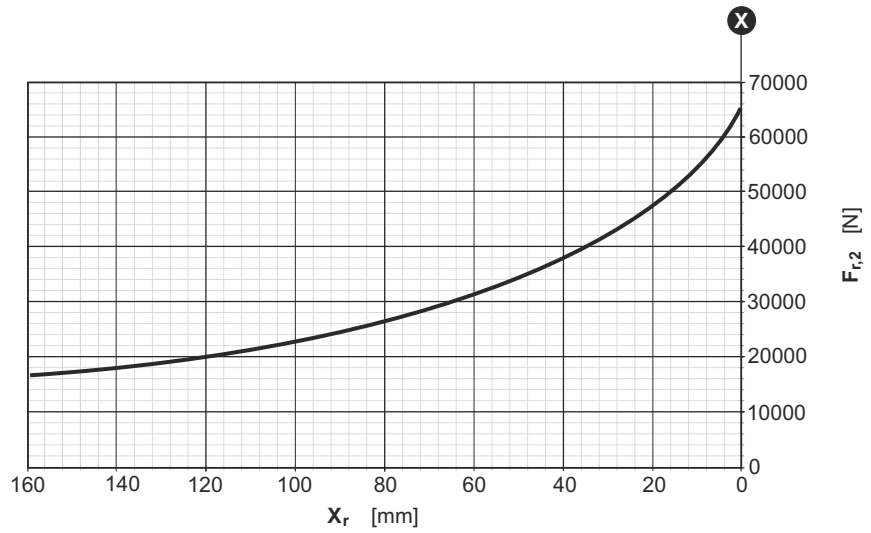
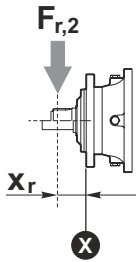

RR	710	..	<b>SS</b>
RA			<b>SC</b>
			<b>SE</b>

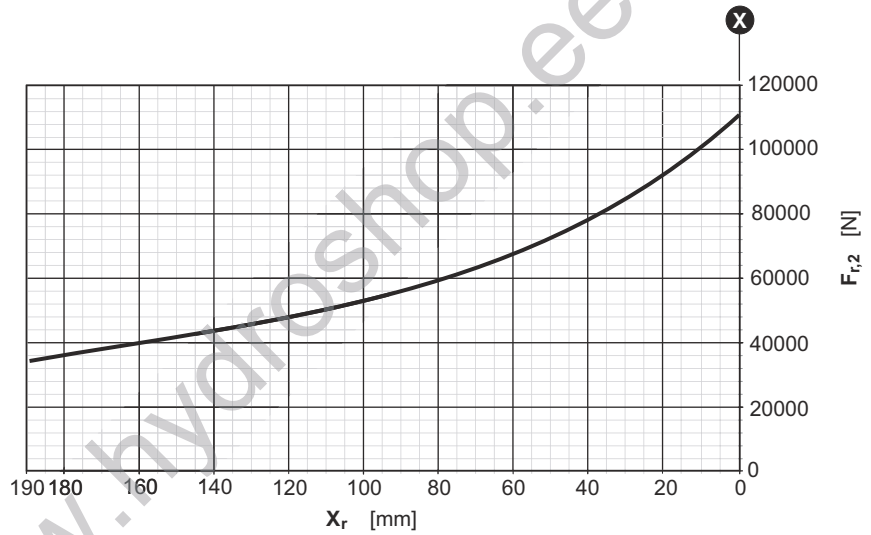
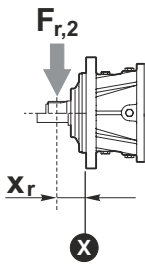

RR	710	..	<b>UC</b>
RA			

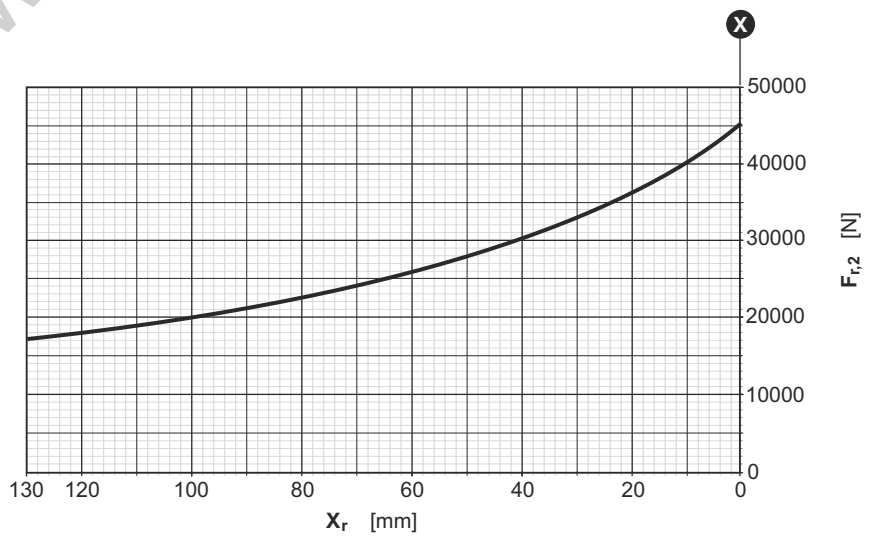
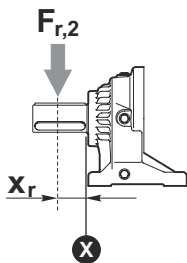



RR 710 .. SI

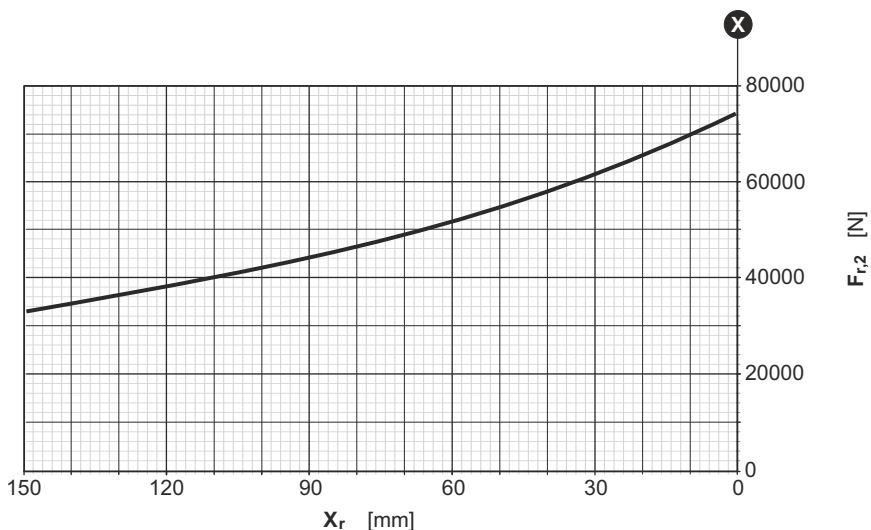
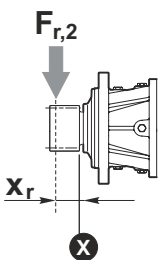

RR 710 .. VI

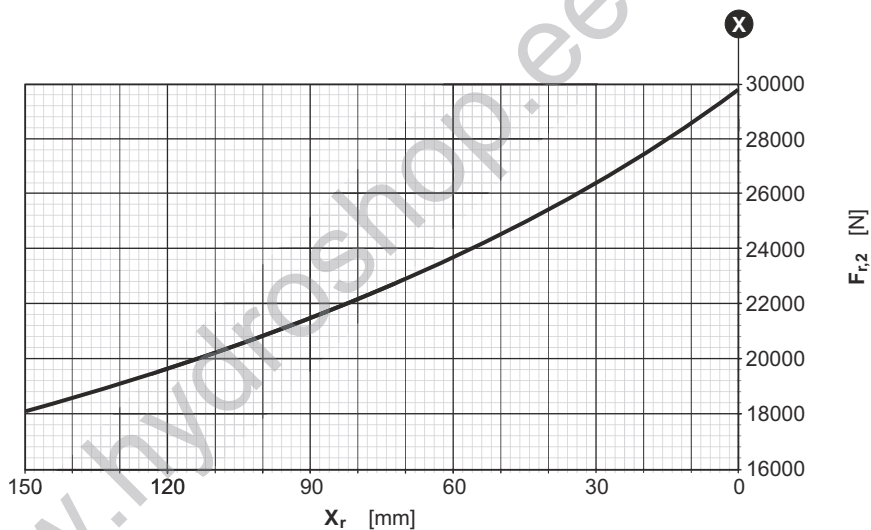
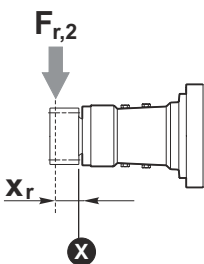

Fattore correttivo  $k_{r2}$  /  $k_{r2}$  Corrective coefficient / Korrekturfaktor  $k_{r2}$   
 Facteur correctif  $k_{r2}$  / Factor de corrección  $k_{r2}$  / Fator corretivo  $k_{r2}$

