

**SERIE
2000**

www.hydrosshop.de

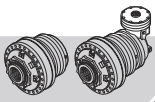

HYDROSHOP



2 IDENTIFICAZIONE DEL PRODOTTO 2 PRODUCT IDENTIFICATION

2 PRODUKTKENNZEICHNUNG

2.1 Composizione di montaggio

2.1 Assembly layout

2.1 Montageaufbau

1. MOTORI
MOTORS
MOTOREN
MOTEURS
MOTOR
MOTOR

2. ENTRATE
INPUTS
EINGÄNGE
ENTREES
ENTRADAS
ENTRADAS

3. FRENI
BRAKES
BREMSEN
FREINS
FRENOS
FREIOS

4. GRUPPI RIDUZIONE
REDUCTION GEAR UNITS
UNTERSETZUNGSGETRIEBE
GROUPES DE REDUCTION
GRUPOS REDUCCIÓN
GRUPOS REDUÇÃO

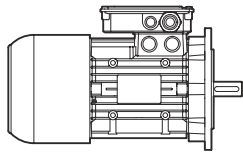

1.1 Motore elettrico
Electrical motor
Elektromotor
Moteur électrique
Motor eléctrico
Motor elétrico

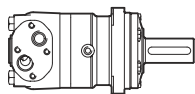

1.2 Motore idraulico
Hydraulic motor
Hydraulikmotor
Moteur hydraulique
Motor hidráulico
Motor hidráulico

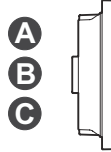

2.1 Entrata standard
Standard input
Standardeingang
Entrée standard
Entrada standard
Entrada padrão

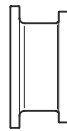

2.2 Accoppiamento motore elettrico
Electrical motor coupling
Kupplung Elektromotor
Accouplement moteur électrique
Acoplamiento motor eléctrico
Acoplagem motor elétrico



2.3 Accoppiamento motore idraulico
Hydraulic motor coupling
Kupplung Hydraulikmotor
Accouplement moteur hydraulique
Acoplamiento motor hidráulico
Acoplagem motor hidráulico

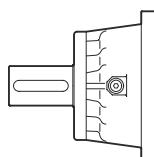

2.4 Entrata veloce
High-speed input
Schneller Eingang
Entrée rapide
Entrada rápida
Entrada rápida

3.1 Freno negativo
Negative brake
Negativbremse
Frein négatif
Freno negativo
Freio negativo

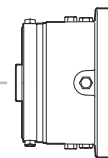

C-12

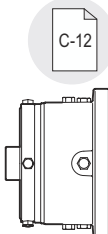

3.2 Freno negativo con accoppiamento per motore idraulico
Negative brake with hydraulic motor coupling
Negativbremse mit Kupplung für Hydraulikmotor
Frein négatif avec accouplement moteur hydraulique
Freno negativo con acoplamiento para motor hidráulico
Freio negativo com acoplagem para motor hidráulico

4.1 Stadio angolare
Angular stage
Winkelstufe
Etage angulaire
Etapa angular
Estádio angular

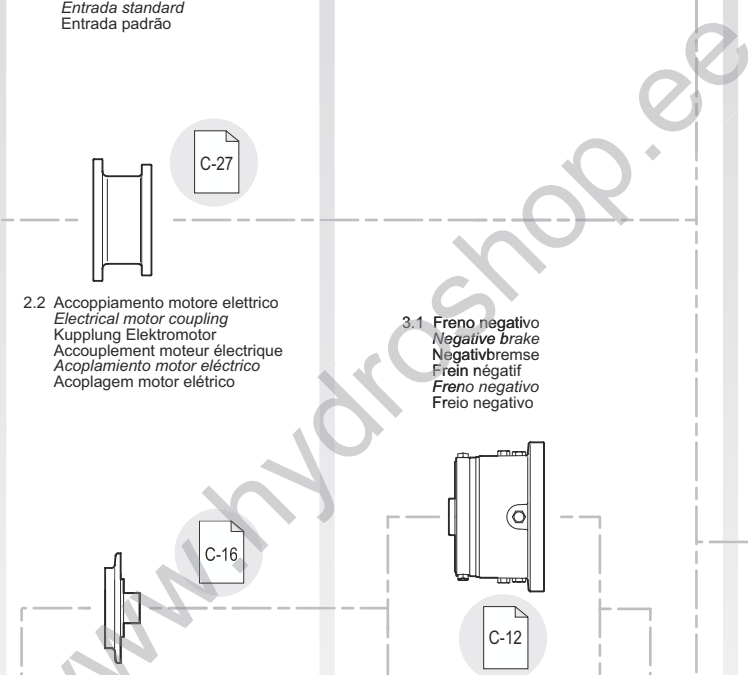
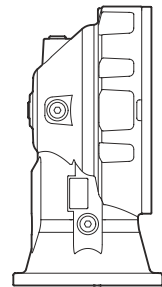

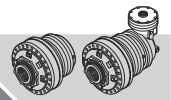

2 IDENTIFICATION DU PRODUIT

2 IDENTIFICACIÓN DEL PRODUCTO

2 IDENTIFICAÇÃO DO PRODUTO

2.1 Composition de montage

2.1 Composición de montaje

2.1 Composição de montagem

4. GRUPPI RIDUZIONE
REDUCTION GEAR UNITS
UNTERSETZUNGSGETRIEBE
GROUPES DE REDUCTION
GRUPOS REDUCCIÓN
GRUPOS REDUÇÃO

4.2 Stadio planetario
Planetary stage
Planetenstufe
Etage planétaire
Etapa planetario
Estádio planetário

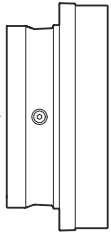

5. USCITE
OUTPUTS
AUSGÄNGE
SORTIES
SALIDAS
SAÍDAS

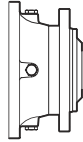

5.1 Uscita M
M Output
Ausgang M
Sortie M
Salida M
Saída M

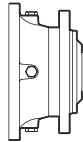

5.2 Uscita B
B Output
Ausgang B
Sortie B
Salida B
Saída B

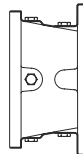

5.3 Uscita S
S Output
Ausgang S
Sortie S
Salida S
Saída S

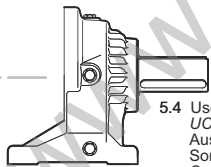

5.4 Uscita UC
UC Output
Ausgang UC
Sortie UC
Salida UC
Saída UC

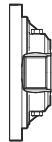

5.5 Uscita FS
FS Output
Ausgang FS
Sortie FS
Salida FS
Saída FS

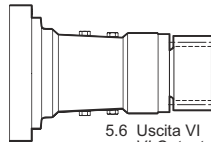

5.6 Uscita VI
VI Output
Ausgang VI
Sortie VI
Salida VI
Saída VI

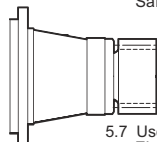

5.7 Uscita ZI
ZI Output
Ausgang ZI
Sortie ZI
Salida ZI
Saída ZI

6. ALBERI
SHAFTS
WELLEN
ARBRES
EJES
EIXOS



S



C



H



E



S



C



H



E



S



C



E



I

7. ACCESSORI USCITA
OUTPUT ACCESSORIES
ZUBEHÖR AUSGANG
ACCESSOIRES SORTIE
ACCESORIOS SALIDA
ACESSÓRIOS SAÍDA



7.1 Flangia presa moto-tipo 28
Drive intake flange – type 28
Antriebsflansch – Typ 28
Bride prise mouvement – type 28
Brida toma movimiento – tipo 28
Flange tomada movimento – tipo 28



7.4 Flangetta di fissaggio-tipo 12
End plate – type 12
Befestigungsflansch – Typ 12
Bride de fixation – type 12
Brida de sujeción – tipo 12
Pequena flange de fixação – tipo 12



7.2 Boccola scanalata-tipo 29
Splined bush – type 29
Nutbuchse – Typ 29
Douille cannelée – type 29
Buje acanalado – tipo 29
Disco com ranhuras – tipo 29



7.3 Pignone-tipo 16
Pinion – type 16
Nutbuchse – Typ 16
Douille cannelée – type 16
Buje acanalado – tipo 16
Disco com ranhuras – tipo 16



7.5 Calettatore per attrito
Friction shrink disc
Schrumpfscheibe
Frette de serrage par frottement
Engargolador por fricción
Encaixador por atrito



7.6 Albero scanalato-tipo 27
Splined shaft – type 27
Keilwelle – Typ 27
Arbre cannelé – type 27
Eje acanalado – tipo 27
Veio com ranhuras – tipo 27

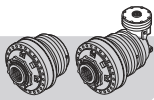

2.2 Designazione

I riduttori epicicloidali Reggiana Riduttori vengono identificati mediante una sigla composta nel seguente modo:

2.2 Designation

The Reggiana Riduttori planetary reduction gears are identified by an acronym made up in the following way:

2.2 Bezeichnung

Die Planetengetriebe von Reggiana Riduttori sind durch einen Code gekennzeichnet, der folgende Bedeutung hat:

RR 510 T FS 65.60 RF

Configurazione ingresso (opzionale) / Input configuration (optional)
Konfiguration am Eingang (optional)

- Ingresso standard / Standard input / Standardeingang
- RF Predisposizione RF / Setup RF / Auslegung RF
- BOC Predisposizione BOC / Setup BOC / Auslegung BOC

Rapporto di riduzione / Reduction ratio / Untersetzungsverhältnis

i = 3 - 3000

Tipo di uscita / Type of output / Typ Ausgang

- MS/BS Maschio scanalato / Male splined / Zum Einstecken mit Nut
- MC/BC Maschio cilindrico / Male cylindrical / Zum Einstecken zylindrisch
- MH/BH Maschio cavo / Male hollow / Zum Einstecken hohl
- ME/BE Maschio esagonale / Male hexagonal / Zum Einstecken sechseckig /
- SS Rinforzato scanalato / Splined reinforced / Verstärkt mit Nut
- SC Rinforzato cilindrico / Cylindrical reinforced / Verstärkt zylindrisch
- SE Rinforzato esagonale / Hexagonal reinforced / Verstärkt sechseckig
- SI Rinforzato con pignone integrale / Reinforced with integral pinion / Verstärkt mit integriertem Ritzel
- UC Maschio cilindrico, con piedi / Male cylindrical, with feet / Zum Einstecken zylindrisch, mit Füßen
- FS Femmina scanalato / Female splined / Zum Aufstecken mit Nut
- VI Pignone integrale (doppio centraggio) / Integral pinion (double centring) / Integriertes Ritzel (doppelte Zentrierung)
- ZI Pignone integrale (con flangia) / Integral pinion (with flange) / Integriertes Ritzel (mit Flansch)

Numero stadi / Number of stages / Anzahl Stufen

- Singolo stadio / Single stage / Einstufig
- D Doppio stadio / Double stage / Zweistufig
- T Triplo stadio / Triple stage / Dreistufig
- Q Quadruplo stadio / Quadruple stage / Vierstufig

Grandezza / Size / Grösse

65, 105, 110, 210, 310, 510, 710, 810, 1010, 1700

Esecuzione

- RR Riduttore lineare
- RA Riduttore angolare

Nel caso sia possibile montare più di una grandezza di coppia conica in ingresso, le diverse alternative per le combinazioni risultanti si indicano con (A) e (B), a partire dall'alternativa con coppia conica più piccola.
Esempio: RA1700 (A), RA1700 (B).

*If it is possible to mount more than one bevel gear size in input, the different alternatives for the combinations are indicated with (A), (B) and (C) starting from the alternative with the smallest bevel gear.
Example: RA1700 (A), RA1700 (B).*

Falls mehrere Kegelpaargrößen am Eingang montiert werden können, werden die alternativen Kombinationen mit (A), (B) und (C) angegeben, ausgehend vom kleinsten Kegelpaar.
Beispiel: RA1700 (A), RA1700 (B).

2.3 Marcatura del prodotto e designazione del tipo

Tutti i prodotti Reggiana Riduttori sono dotati di targhetta di identificazione, posizionata in modo da risultare facilmente leggibile, anche dopo l'installazione.

La seguente figura mostra un esempio di targhetta.

2.3 Product marking and type designation

All Reggiana Riduttori products have an id plate positioned so as to be easily readable also after installation.

The following figure shows an example of a plate.

2.3 Produktkennzeichnung und Typschild

Alle Produkte von Reggiana Riduttori weisen ein Typenschild auf, das so angebracht ist, dass es auch nach der Installation leicht abgelesen werden kann.

Die Abbildung unten zeigt ein Beispi.

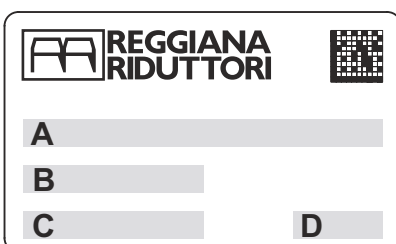

	Legenda	Legend	Legende
A	Tipo di riduttore e rapporto	Reduction gear type and ratio	Untersetzungstyp und Untersetzungsverhältnis
B	Codice identificativo di ordinazione	ID code for ordering	Identifizierungscode der Bestellung
C	N° progressivo di matricola	Progressive serial number	Fortlaufende Seriennummer
D	Mese/anno di produzione	Months/year of production	Monat/Baujahr



2.2 Designation

Les réducteurs épicycloïdaux Reggiana Riduttori sont identifiés au moyen d'un sigle composé de la manière suivante:

2.2 Denominación

Los reductores epicicloidales Reggiana Riduttori están identificados por una sigla formada como sigue:

2.2 Designação

Os redutores epicicloidais Reggiana Riduttori são identificados mediante uma referência composta no seguinte modo:

RR	510	T	FS	65.60	RF
<p>Configuración a l'entrèe (en option) / Configuración en entrada (opcional) / Configuração em entrada (opcional)</p> <p>- Entrèe standard / <i>Entrada estándar</i> / Entrada padrão RF Prèrèglage RF / <i>Predisposición RF</i> / Predisposição RF BOC Prèrèglage BOC / <i>Predisposición BOC</i> / Predisposição BOC</p> <p>Rapport de réduction / Relación de reducción / Relação de redução <i>i</i> = 3 - 3000</p> <p>Type de sortie / Tipo de salida / Tipo de saída</p> <p>MS/BS Mâle cannelé / <i>Macho acanalado</i> / Macho com ranhuras MC/BC Mâle cylindrique / <i>Macho cilíndrico</i> / Macho cilíndrico MH/BH Mâle creux / <i>Macho hueco</i> / Macho ôco ME/BE Mâle hexagonal / <i>Macho hexagonal</i> / Macho hexagonal SS Renforcé cannelé / <i>Reforzado acanalado</i> / Reforçado com ranhuras SC Renforcé cylindrique / <i>Reforzado cilíndrico</i> / Reforçado cilíndrico SE Renforcé hexagonal / <i>Reforzado hexagonal</i> / Reforçado hexagonal SI Renforcé avec pignon intégral / <i>Reforzado con piñón integral</i> / Reforçado com pinhão integrado UC Mâle cylindrique avec pieds / <i>Macho cilíndrico, con patas</i> / Macho cilíndrico com pé FS Femelle cannelée / <i>Hembra acanalada</i> / Fêmea com ranhuras VI Pignon intégral (Double centrage) / <i>Piñón integral (doble centrado)</i> / Pinhão integrado (dupla centragem) ZI Pignon intégral (Avec bride) / <i>Piñón integral (con brida)</i> / Pinhão integrado (Com flange)</p> <p>Numero stadi / Number of stages / Anzahl Stufen</p> <p>— Simple étage / <i>Etapa individual</i> / Um estágio D Double étage / <i>Doble etapa</i> / Duplo estágio T Triple étage / <i>Triple etapa</i> / Triplo estágio Q Quadruple étage / <i>Cuádruple etapa</i> / Quadruplo estágio</p> <p>Grandezza / Size / Grösse 65, 105, 110, 210, 310, 510, 710, 810, 1010, 1700</p> <p>Esecuzione RR Riduttore lineare RA Riduttore angolare</p>					

Si'il est possible de monter plus d'une grandeur de couple conique à l'entrèe, les différentes alternatives pour les combinaisons possibles sont indiquées par les lettres (A), (B) et (C), à partir de l'alternative avec un couple conique plus petit.
 Exemple: RA1700 (A), RA1700 (B).

Si fuese posible montar más de una talla de par cónico en entrada, las diferentes alternativas para las combinaciones resultante se indican con (A), (B) y (C), a partir de la alternativa con par cónico más pequeño.

Ejemplo: RA1700 (A), RA1700 (B).

No caso em que seja possível montar mais do que uma grandeza de par cónico em entrada, as várias alternativas para as combinações que resultam são indicadas com (A), (B) e (C), a partir da alternativa com par cónico mais pequeno.
 Exemplo: RA1700 (A), RA1700 (B).

2.3 Marquage du produit et désignation du type

Sur tous les produits Reggiana Riduttori, une plaquette d'identification est appliquée. Elle est positionnée de manière à être facile à lire, même une fois le réducteur installé.

La figure suivante montre un exemple de la plaquette.

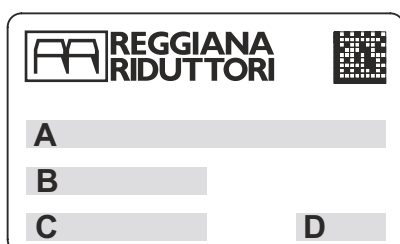

2.3 Marcado del producto y denominación del tipo

Todos los productos Reggiana Riduttori llevan una placa de identificación, colocada de manera que resulte fácilmente legible, también después de la instalación.

La siguiente figura presenta un ejemplo de placa.

2.3 Marcação do produto e designação do tipo

Todos os produtos Reggiana Riduttori são munidos de placa de identificação, colocada de modo a ser lida com facilidade, também depois da instalação.

A seguinte figura ilustra um exemplo de placa.

	Légende	Leyenda	Legenda
A	Type de réducteur et rapport de réduction	<i>Tipo de reductor y relación de reducción</i>	Tipo de reductor e relação de redução
B	Code d'identification de la commande	<i>Código identificador de pedido</i>	Código identificativo de encomenda
C	N° progressif de série	<i>N° progresivo de matrícula</i>	N° progressivo de matrícula
D	Mois/année de fabrication	<i>Mes/año de producción</i>	Mês/ano de produção

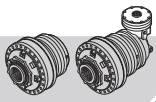

Produttore Manufacturer Hersteller	Oli Idrraulici Hydraulic oils Hydrauliköle			Oli per ingranaggi Gear oils Getriebeöle		
	ISO VG 32	ISO VG 46	ISO VG 68	ISO VG 150	ISO VG 220	ISO VG 320
AGIP	Rocol Foodlube Hi Power 32	-	-	Rocol Foodlube Hi-Torque 150	-	Rocol Foodlube Hi-Torque 320
BP	Enerpar M 32	Enerpar M 46	Enerpar M 68	-	-	-
KLÜBER	Summit Hysyn FG 32	Summit Hysyn FG 46	Summit Hysyn FG 68	Klüberoil 4 UH1 N 150	Klüberoil 4 UH1 N 220	Klüberoil 4 UH1 N 320
MOBIL	DTE FM 32	DTE FM 46	DTE FM 68	DTE FM 150	DTE FM 220	DTE FM 320
SHELL	Cassida Fluid HF 32	Cassida Fluid HF 46	Cassida Fluid HF 68	Cassida Fluid GL 150	Cassida Fluid GL 220	Cassida Fluid GL 320
TEXACO	Cygnus Hydraulic Oil 32	Cygnus Hydraulic Oil 46	Cygnus Hydraulic Oil 68	Cygnus Gear PAO 150	Cygnus Gear PAO 220	-
TOTAL	Nevastane AW 32	Nevastane AW 46	Nevastane AW 68	Nevastane SL 150	Nevastane SL 220	Nevastane SL 320
TRIBOL	Food Proof 1840/32	Food Proof 1840/ 46	Food Proof 1840/68	-	Food Proof 1810/220	Food Proof 1810/320

Nel caso di impiego di altri lubrificanti sintetici, verificarne la compatibilità con le tenute paraolio in NBR presenti nel riduttore.

If other synthetic lubricants are used always check their compatibility with the NBR oil seals used in the reduction gear.

Bei Verwendung synthetischer Schmiermittel muss die Kompatibilität mit den im Planetengetriebe montierten Öldichtungen aus NBR geprüft werden.



Non mescolare lubrificanti sintetici di tipo differente.

Do not mix different kinds of synthetic lubricant together.

Unterschiedliche Typen von synthetischen Schmiermitteln dürfen nicht gemischt werden.

Se le condizioni di esercizio del riduttore prevedono prolungati periodi di funzionamento tali da produrre una elevata temperatura dell'olio (>60°C) si consiglia l'utilizzo di olio sintetico, per garantire una minore usura dei componenti ed aumentare gli intervalli di sostituzione.

If the operating conditions of the reduction gear entail prolonged periods of operation such to cause the oil temperature to rise considerably (>60°C) we suggest using a synthetic oil to guarantee less wear of the components and to prolong the intervals between replacing them.

Wenn die Betriebsbedingungen vom Planetengetriebe längere Betriebszeiten vorsehen, die zu hohen Öltemperaturen führen (>60°C), wird zur Verwendung von synthetischem Öl geraten, das für einen geringeren Verschleiß der Teile und größere Abstände zwischen den Ölwechseln garantiert.

La temperatura massima del lubrificante all'interno del riduttore non deve oltrepassare i 90°C.

Maximum temperature of the lubricant inside the reduction gear must not go above 90°C.

Die Temperatur vom Schmiermittel im Planetengetriebe darf 90°C nicht übersteigen.

6.4 Posizioni di montaggio e disposizione dei tappi

Nelle figure seguenti sono mostrate le possibili posizioni di montaggio, la cui sigla deve essere specificata in fase di ordine del riduttore.

Inoltre sono indicati la disposizione e la tipologia dei tappi ed il livello minimo di lubrificante, come da legenda.

Attenzione:

Per servizi continuativi (24 h) consigliamo di utilizzare tappi di sfiato con il labirinto e filtro sinterizzato assieme ad una colonnetta.

6.4 Mounting positions and plugs position

You can see the possible mounting positions in the figures below. The relative initial must be specified when ordering the reduction gear.

The layout and type of plugs as well as the minimum lubricant level are also indicated, as per the legend.

Attention!

For continuous duty (24h) uses venting plug with labyrinth and filter and a column.

6.4 Montageposition und Anordnung der Deckel

Die Abbildungen unten zeigen die möglichen Montagepositionen, deren Kürzel bei der Bestellung vom Planetengetriebe angegeben werden muss.

Außerdem sind die Anordnung und der Typ der Deckel sowie der Mindestölstand angegeben (siehe Legende).

Achtung!

Bei Dauerbetrieb ist es besser auf Säule gebauten Belüftungspfpfen mit synthetischem Filter und Labyrinth einzusetzen.

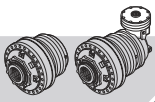

- ① Carico e sfiato
Filling up and venting
Füllen und Entlüften
- ② Livello
Level
Ölstand
- ③ Scarico
Drainage
Ablass
- ④ Sfiato durante il carico
Venting while filling up
Entlüften beim Füllen
- Livello minimo
Minimum level
Mindestölstand

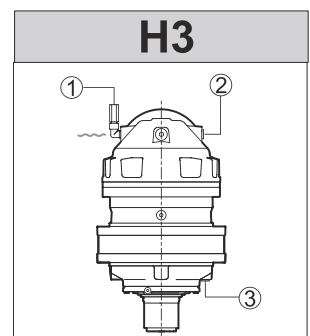
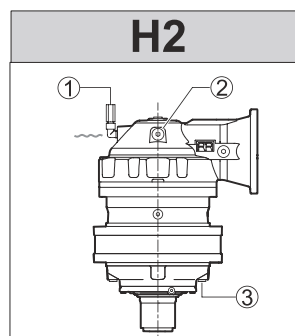
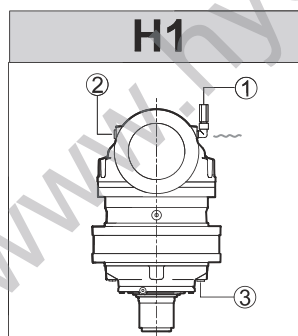
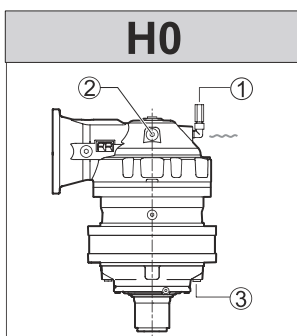
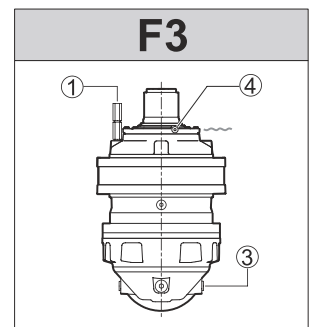
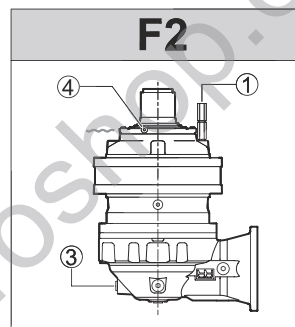
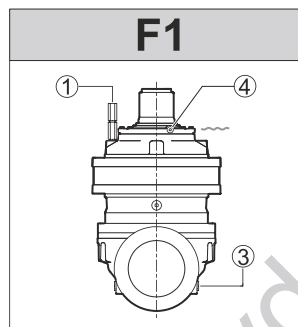
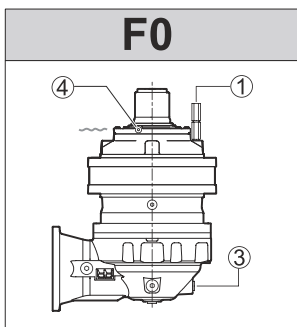
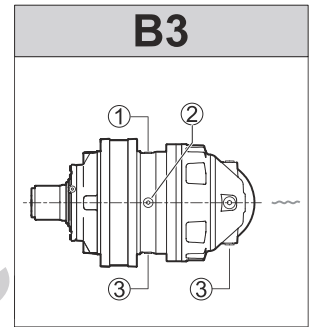
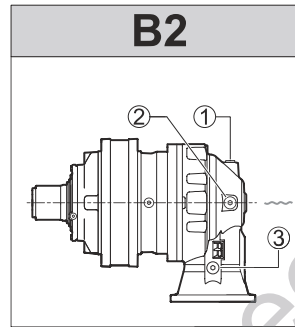
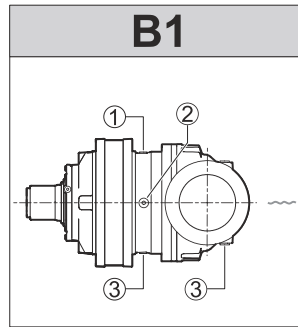
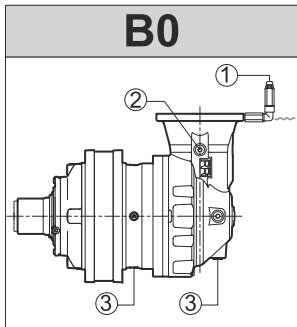
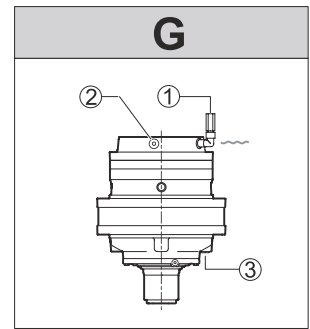
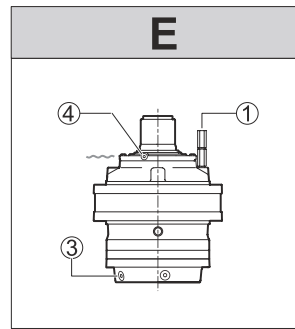
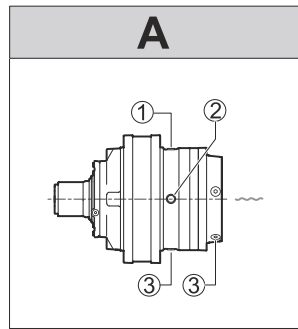

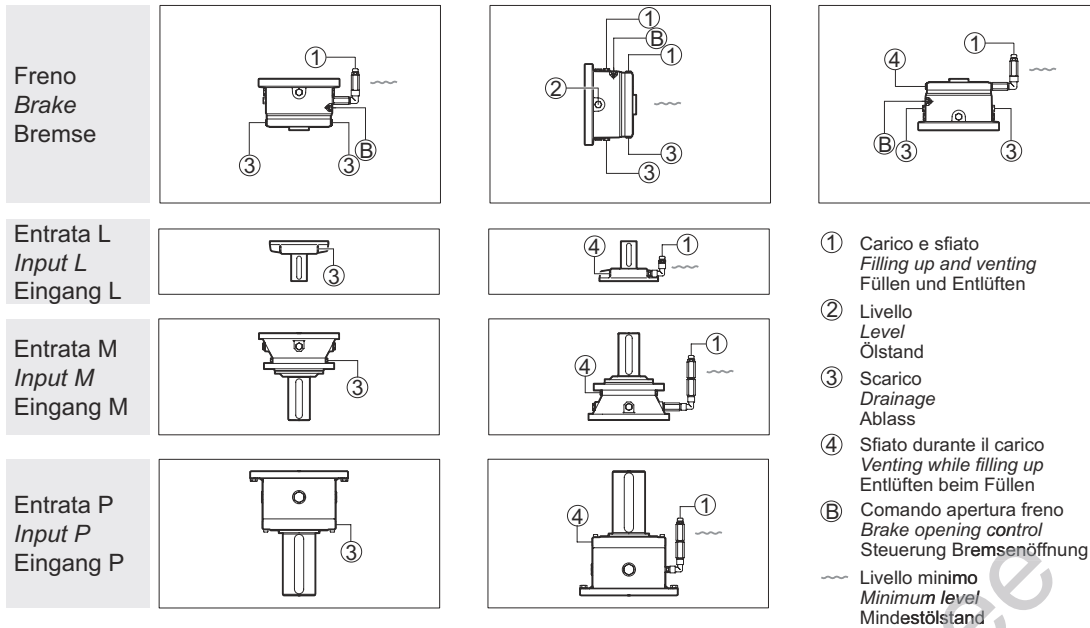
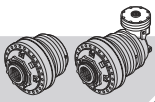

6.5 Riempimento

Per le posizioni di montaggio A, B1, B2 e B3 il riempimento va effettuato fino alla mezzeria del riduttore; il corretto livello del lubrificante può essere verificato mediante gli appositi tappi di livello, indicati con (2) nella figura precedente.

Per applicazioni dove la velocità di rotazione in uscita è bassa ($n_2 \leq 5rpm$) consigliamo di riempire 3/4 del volume totale del riduttore di olio.

Se la velocità di rotazione in uscita è molto bassa ($n_2 \leq 1rpm$), o per lunghi periodi di stoccaggio, è consigliabile riempire tutto il riduttore con olio. In questo caso bisogna prevedere l'utilizzo di un vaso d'espansione che consenta l'espansione del volume dell'olio all'aumentare della temperatura.

Per le posizioni di montaggio E, G, B0, F0, F1, F2, F3, H0, H1, H2 e H3, è necessario effettuare il completo riempimento, in modo da consentire la corretta lubrificazione dei componenti posti nella parte più alta del riduttore. In questo caso durante il riempimento occorre rimuovere almeno uno dei tappi posti nella parte più alta del riduttore, indicati con (4) nella figura precedente, in modo da evitare la formazione di bolle d'aria.

6.5 Filling up

For the assembly positions A, B1, B2 and B3 fill up to the halfway point of the reduction gear; the right level of the lubricant can be checked with the level plugs, indicated with (2) in the previous figure.

For applications with low output rotation speeds ($n_2 \leq 5rpm$) we advise you to fill the reduction gear with oil to 3/4 of the total volume.

For very low output rotation speeds ($n_2 \leq 1rpm$) or when storing for long periods of time, fill the reduction gear completely with oil. In this case, use an expansion tank to allow the oil volume to increase according to temperature.

For the assembly positions E, G, B0, F0, F1, F2, F3, H0, H1, H2 and H3, they have to be filled right up to the top to allow correct lubrication of the components situated at the upper most part of the reduction gear. In this case, when filling up, you have to remove at least one of the plugs from the upper most part of the reduction gear, indicated with (4) in the previous figure, so as to prevent air bubbles forming.

6.5 Einfüllen vom Öl

Bei den Montagepositionen A, B1, B2 und B3 erfolgt das Einfüllen bis zur Mittellinie vom Planetengetriebe. Der korrekte Ölstand kann über die dafür vorgesehenen Ölstandsdeckel kontrolliert werden (siehe Abbildung oben (2)).

Für Anwendungen, bei denen die Rotationsgeschwindigkeit im Ausgang niedrig ist ($n_2 \leq 5UpM$), empfehlen wir, das Getriebe bis zu einem 3/4 des Gesamtvolumens mit Öl zu füllen. Wenn die Rotationsgeschwindigkeit im Ausgang sehr niedrig ist ($n_2 \leq 1UpM$) oder für lange Lagerzeiten, ist es ratsam, das gesamte Getriebe mit Öl zu füllen. In diesem Fall, muss die Verwendung eines Ausdehnungsgefäßes vorgesehen werden, das die Ausdehnung des Ölvolumens bei Erhöhung der Temperatur gestattet.

Bei den Montagepositionen E, G, B0, F0, F1, F2, F3, H0, H1, H2 und H3 ist eine komplette Füllung erforderlich, um die korrekte Schmierung der Teile an der höchsten Stelle im Planetengetriebe zu garantieren. In diesem Fall muss beim Einfüllen mindestens einer der Deckel oben (Abbildung oben (4)) abgenommen werden, damit sich keine Luftblasen bilden.



RR210

..

i



i	T ₂ [Nm]						n _{1max} [min ⁻¹]	T _{2max} [Nm]	P _t [kW]					
	n ₂ x h													
1/...	10000 (10 ⁴)	25000 (2.5 · 10 ⁴)	50000 (5 · 10 ⁴)	100000 (10 ⁵)	500000 (5 · 10 ⁵)	1000000 (10 ⁶)								
RR210	3.31	2500	2360	2330	2180	1610	1310	3500	2500 (M.../FS)	15				
	3.91	2480	2300	2110	1860	1580	1290							
	4.94	2210	1860	1630	1490	1350	1250							
	5.78	2030	1710	1500	1410	1270	1220							
	7.09	1390	1160	1030	990	890	860							
RR210D	10.96	2500	2360	2330	2180	1610	1310	3500	2500 (M.../FS)	8				
	12.94	2500	2360	2330	2180	1610	1310							
	15.29	2480	2300	2110	1860	1580	1290							
	19.32	2480	2300	2110	1860	1580	1290							
	22.6	2480	2300	2110	1860	1580	1290							
	28.55	2210	1860	1630	1490	1350	1250							
	35.02	2210	1860	1630	1490	1350	1250							
	40.98	2030	1710	1500	1410	1270	1220							
	50.27	1390	1160	1030	990	890	860							
	RR210T	60.18	2500	2360	2330	2180	1610				1310	3500	2500 (M.../FS)	6
71.09		2480	2300	2110	1860	1580	1290							
80.37		2500	2360	2330	2180	1610	1310							
89.82		2480	2300	2110	1860	1580	1290							
105.09		2480	2300	2110	1860	1580	1290							
119.95		2480	2300	2110	1860	1580	1290							
140.34		2480	2300	2110	1860	1580	1290							
177.32		2210	1860	1630	1490	1350	1250							
217.5		2210	1860	1630	1490	1350	1250							
254.49		2030	1710	1500	1410	1270	1220							
312.16		1390	1160	1030	990	890	860							
RR210Q		279.84	2500	2360	2330	2180	1610	1310	3500	2500 (M.../FS)	5			
		330.57	2480	2300	2110	1860	1580	1290						
	417.65	2480	2300	2110	1860	1580	1290							
	488.66	2480	2300	2110	1860	1580	1290							
	557.76	2480	2300	2110	1860	1580	1290							
	652.6	2480	2300	2110	1860	1580	1290							
	824.52	2210	1860	1630	1490	1350	1250							
	871.54	2480	2300	2110	1860	1580	1290							
	1011.39	2210	1860	1630	1490	1350	1250							
	1183.36	2030	1710	1500	1410	1270	1220							
	1350.69	2210	1860	1630	1490	1350	1250							
	1580.36	2030	1710	1500	1410	1270	1220							
	1938.54	1390	1160	1030	990	890	860							

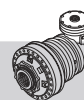

RA210 .. **i**



	i	T ₂ [Nm]						n _{1max} [min ⁻¹]	T _{2max} [Nm]	P _t [kW]
		n ₂ x h								
	1/...	10000 (10 ⁴)	25000 (2.5 · 10 ⁴)	50000 (5 · 10 ⁴)	100000 (10 ⁵)	500000 (5 · 10 ⁵)	1000000 (10 ⁶)			
RA210	10.66	1980	1660	1460	1310	1170	1010	3500	2500 (M.../FS)	14
	12.59	2270	1900	1670	1530	1360	1130			
	15.91	2210	1860	1630	1490	1350	1250			
	18.61	2030	1710	1500	1410	1270	1220			
	22.83	1390	1160	1030	990	890	860			
	29.09	1000	830	770	730	640	600			
	34.03	1140	940	890	840	740	700			
	41.75	1340	1130	1030	990	890	840			
RA210D	35.28	2500	2360	2330	2180	1610	1310	3500	2500 (M.../FS)	10
	41.67	2500	2360	2330	2180	1610	1310			
	49.23	2480	2300	2110	1860	1580	1290			
	62.20	2480	2300	2110	1860	1580	1290			
	72.77	2480	2300	2110	1860	1580	1290			
	91.94	2210	1860	1630	1490	1350	1250			
	112.78	2210	1860	1630	1490	1350	1250			
	131.96	2030	1710	1500	1410	1270	1220			
	161.86	1390	1160	1030	990	890	860			
	196.71	2030	1710	1500	1410	1270	1220			
	206.22	2210	1860	1630	1490	1350	1250			
	241.29	2030	1710	1500	1410	1270	1220			
	295.98	1390	1160	1030	990	890	860			

www.hydroshop.de



RR210 .. i ..

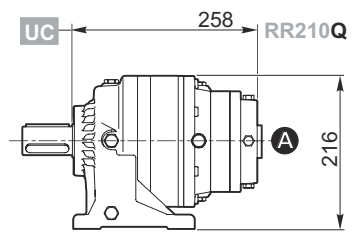
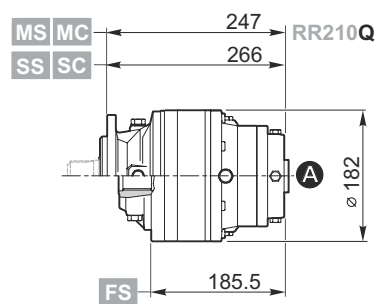
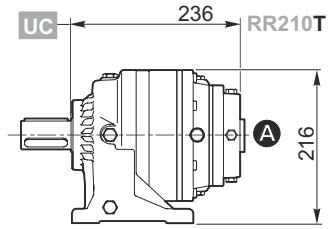
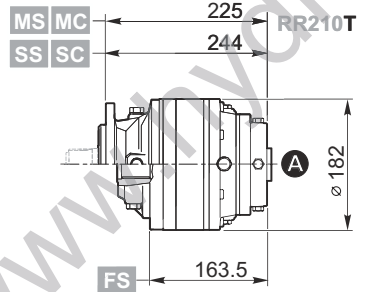
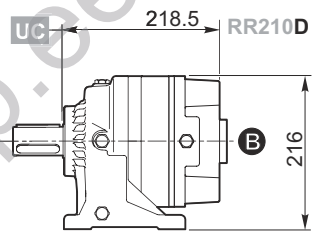
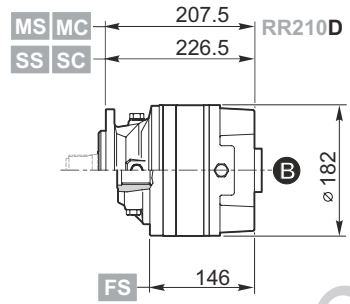
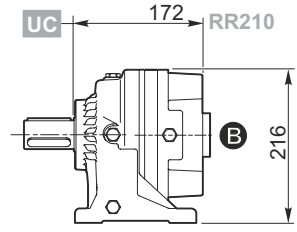
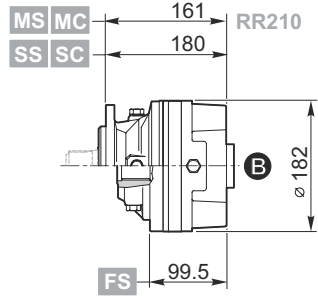

www.hydroshop.be

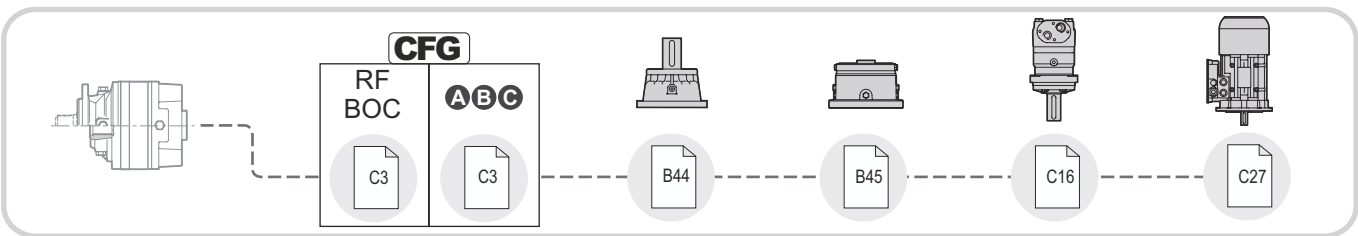



RA210 .. i ..



D

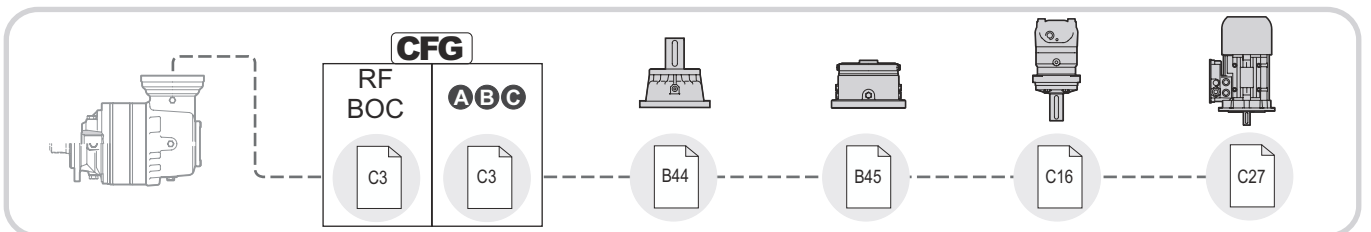
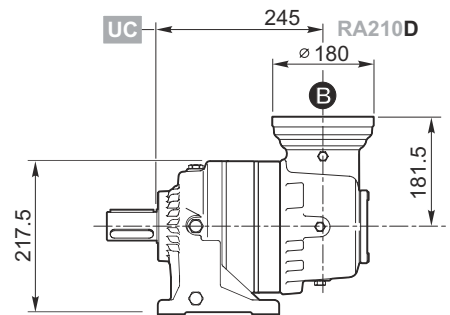
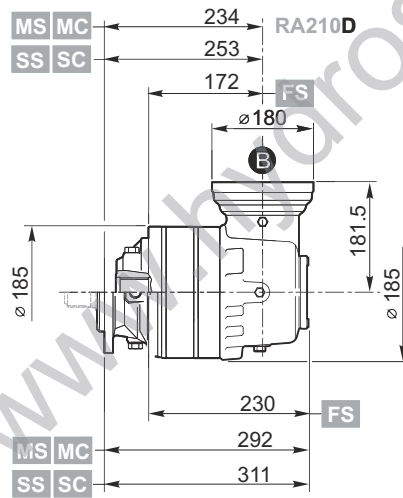
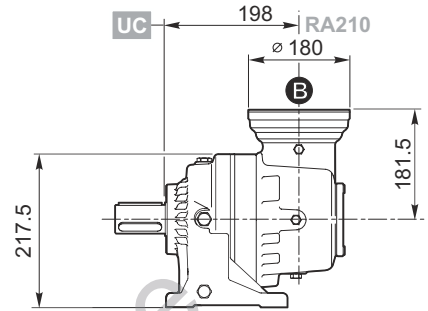
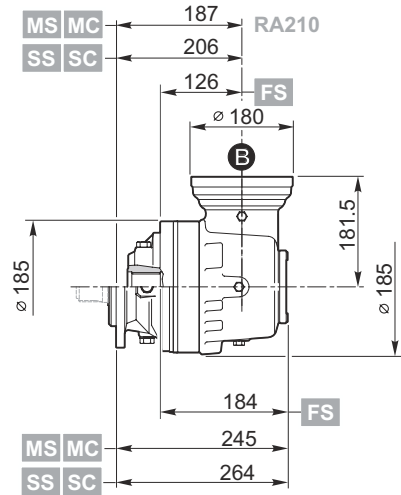

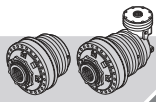

210

IT EN DEFRES PT

RR210	..	i	..
RA210

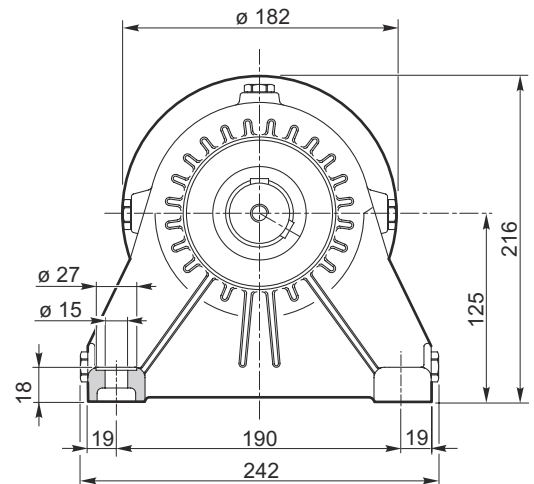
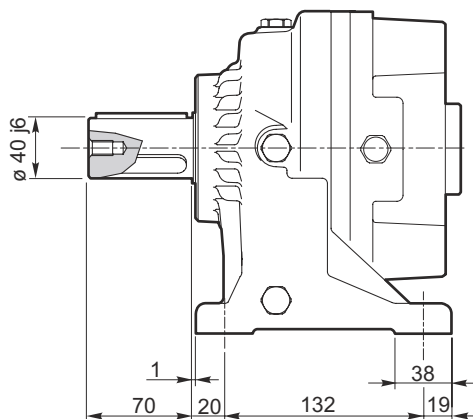
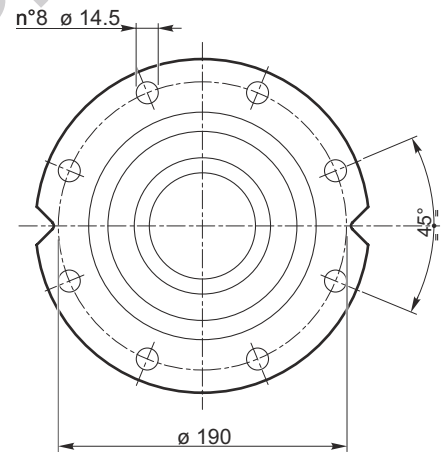
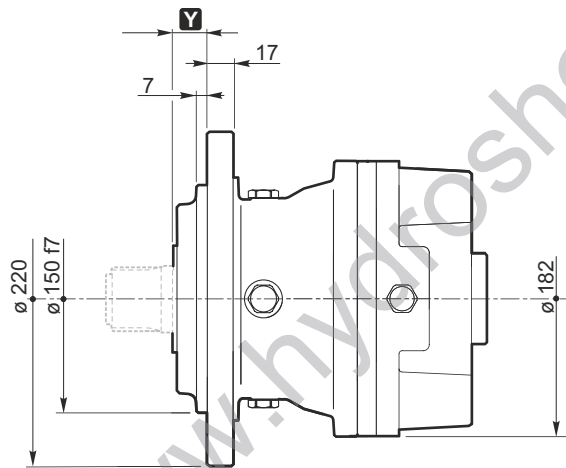
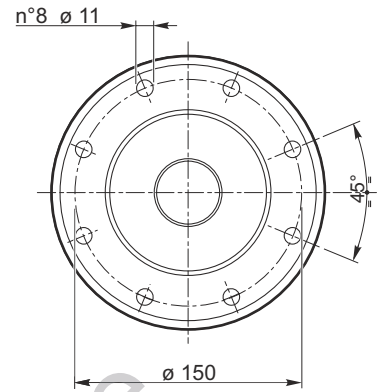
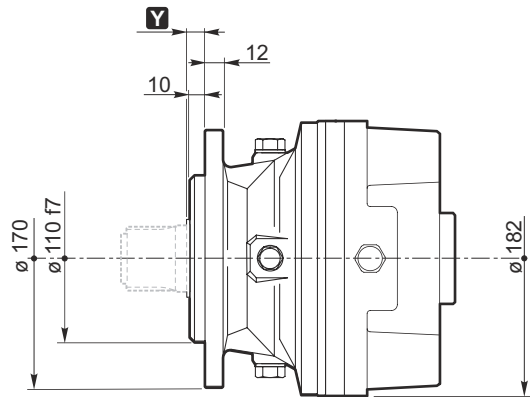

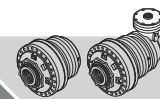

MS

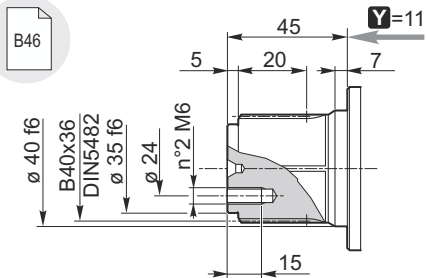
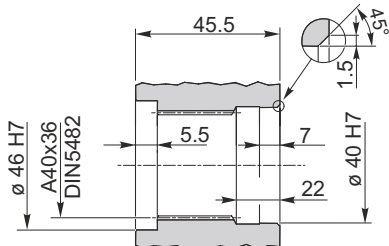
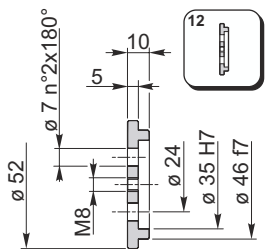

Y=11

SS

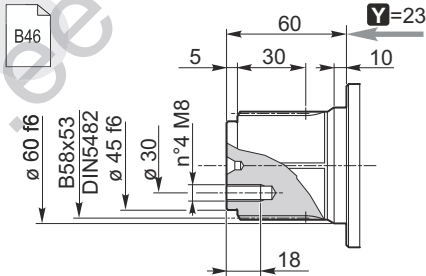
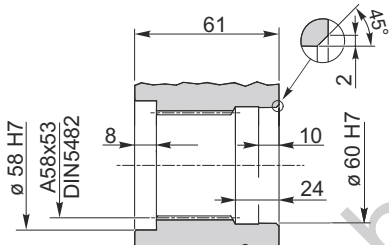
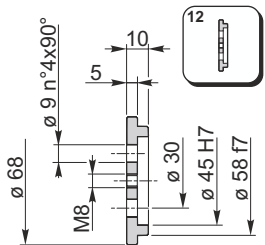

Y=23

MC
UC

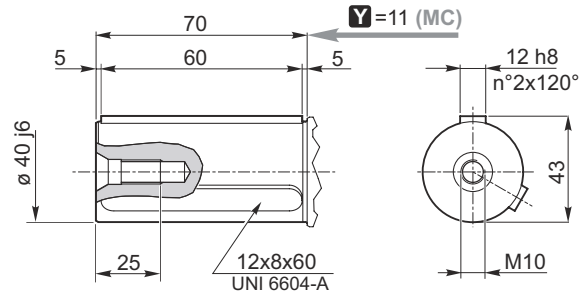
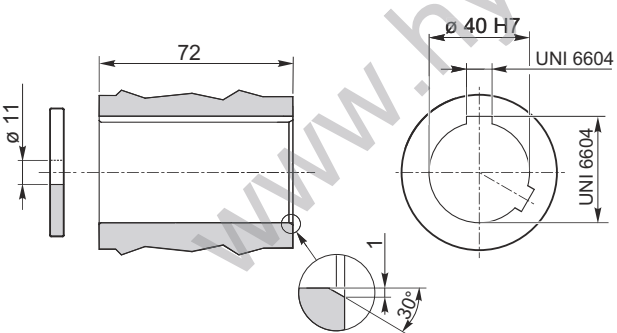

Y=11 (MC)

SC

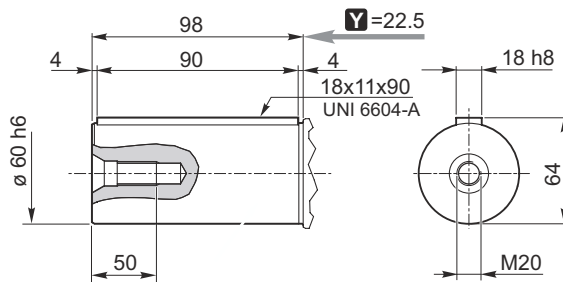
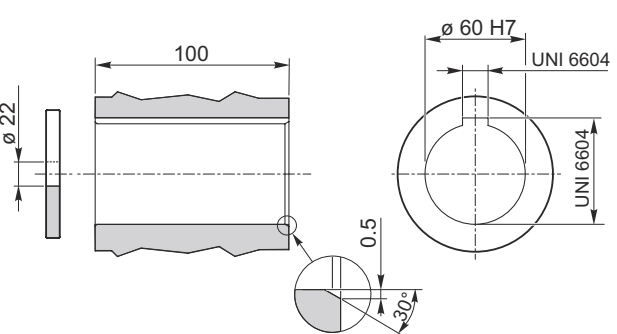

Y=22.5

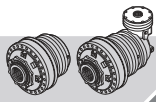

210

IT EN DEFRES PT

RR210	..	i	FS
RA210			

FS

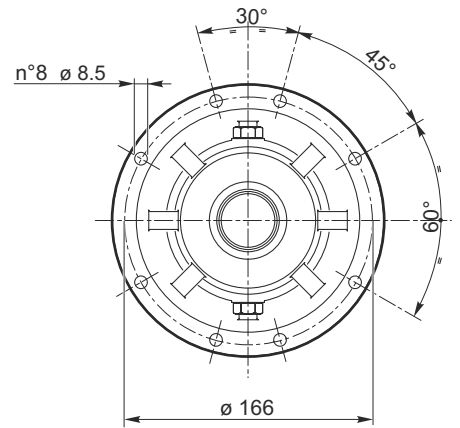
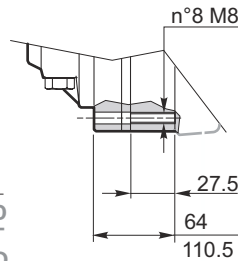
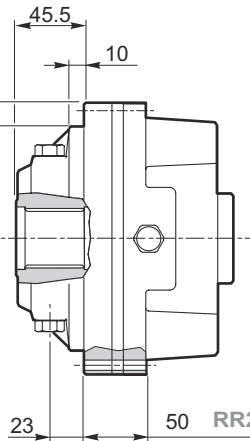

Trattamento termico:
Tempra ad induzione secondo UNI 10932 su scanalato interno

Heat treatment:
Induction hardening according to UNI 10932 on internal spline

Wärmebehandlung:
Induktionshärtung nach UNI 10932 an interner Nut

Traitement thermique :
Trempe par induction conformément à la norme UNI 10932 sur cannelé interne

Tratamiento térmico:
Temple por inducción según UNI 10932 en acanalado interno

Tratamento térmico:
Tempera por indução segundo UNI 10932 sobre ranhuras internas

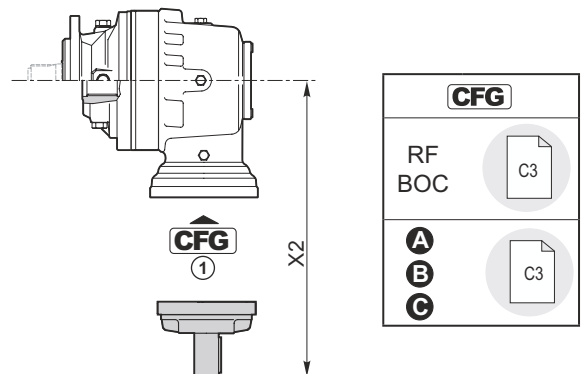
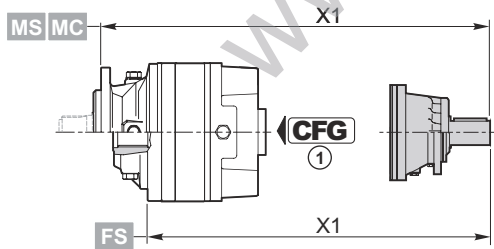
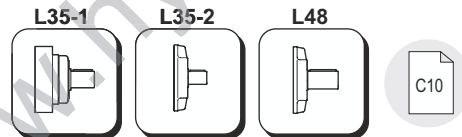
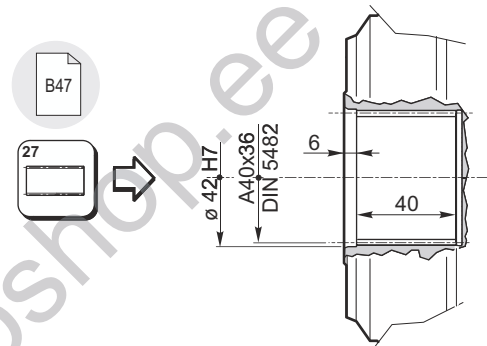
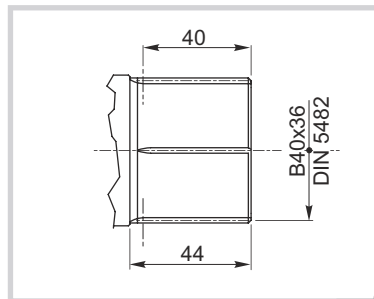

	CFG		code	X1
RR210	BOC	L48	154B3989M1	282.5 (M...) 221 (FS) 301.5 (S...)
RR210D	BOC	L35-2	154-2190M1	297 (M...) 235.5 (FS) 316.5 (S...)
RR210T	RF	L35-1	154B4054	313 (M...) 251.5 (FS) 332 (S...)
RR210Q	RF	L35-1	154B4054M1	335 (M...) 273.5 (FS) 354 (S...)

	CFG		code	X2
RA210	BOC	L35-2	154-2190M1	270.5
RA210D	BOC	L35-2	154-2190M1	270.5

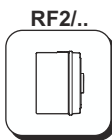
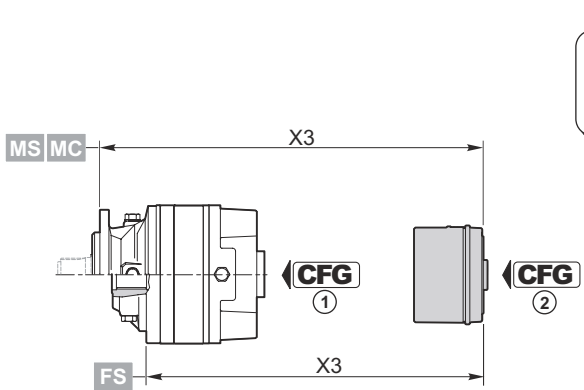

CFG	
RF BOC	
A	
B	
C	

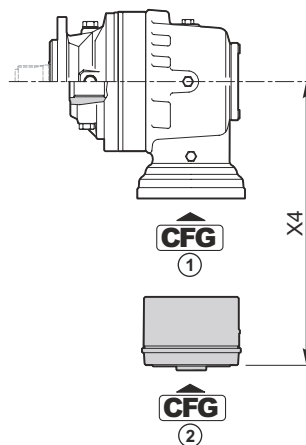

RF2/..	CFG ①	T _f [Nm]	CFG ②							
			B		OMP/OMR SAE A 2B Ø 25	OMP/OMR SAE A 2B 1" 6B	OMP/OMR SAE A 4B Ø 25	OMP/OMR SAE A 4B 1" 6B	X3	
			code	X3	code	code	code	code		
RR210	RF	70	154-2838M1	199.5 (M...) 138 (FS) 218.5 (S...)	154-2863	154-2863M11	154-2635	154-2635M11	189.5 (M...) 128 (FS) 208.5 (S...)	
		140	154-2839M1		154-2864	154-2864M11	154-2636	154-2636M11		
		210	154-2840M1		154-2865	154-2865M11	154-2637	154-2637M11		
		320	154-2841M1		154-2866	154-2866M11	154-2638	154-2638M11		
		430	154-2842M1		154-2867	154-2867M11	154-2639	154-2639M11		
		600	154B8962M1		154B9665	154B9665M11	154B9666	154B9666M11		
RR210D	RF	70	154-2838M1	246 (M...) 184.5 (FS) 265 (S...)	154-2863	154-2863M11	154-2635	154-2635M11	236 (M...) 174.5 (FS) 255 (S...)	
		140	154-2839M1		154-2864	154-2864M11	154-2636	154-2636M11		
		210	154-2840M1		154-2865	154-2865M11	154-2637	154-2637M11		
		320	154-2841M1		154-2866	154-2866M11	154-2638	154-2638M11		
		430	154-2842M1		154-2867	154-2867M11	154-2639	154-2639M11		
		600	154B8962M1		154B9665	154B9665M11	154B9666	154B9666M11		

	CFG ①	T _f [Nm]	CFG ②							
			A		OMP/OMR SAE A 2B Ø 25	OMP/OMR SAE A 2B 1" 6B	OMP/OMR SAE A 4B Ø 25	OMP/OMR SAE A 4B 1" 6B	X3	
			code	X3	code	code	code	code		
RR210T	RF	70	154-2832M1	291 (M...) 229.5 (FS) 310 (S...)	154-2858M1	154-2858M5			286.5 (M...) 225 (FS) 305.5 (S...)	
		140	154-2833M1		154-2859M1	154-2859M5				
		210	154-2834M1		154-2860M1	154-2860M5				
		320	154-2836M1		154-2861M1	154-2861M5				
		430	154-2837M1		154-2862M1	154-2862M5				
		600	154B8959M1		154B9663M1	154B9663M5				
RR210Q	RF	70	154-2832M3	313 (M...) 251.5 (FS) 332 (S...)	154-2858M3	154-2858M7			308.5 (M...) 247.5 (FS) 327.5 (S...)	
		140	154-2833M3		154-2859M3	154-2859M7				
		210	154-2834M3		154-2860M3	154-2860M7				
		320	154-2836M3		154-2861M3	154-2861M7				
		430	154-2837M3		154-2862M3	154-2862M7				
		600	154B8959M3		154B9663M3	154B9663M7				

	CFG ①	T _f [Nm]	CFG ②							
			B		OMP/OMR SAE A 2B Ø 25	OMP/OMR SAE A 2B 1" 6B	OMP/OMR SAE A 4B Ø 25	OMP/OMR SAE A 4B 1" 6B	X4	
			code	X4	code	code	code	code		
RA210	RF	70	154-2838M12	223.8	154-2863M12	154-2863M13	154-2635M12		213.8	
		140	154-2839M12		154-2864M12	154-2864M13	154-2636M12			
		210	154-2840M12		154-2865M12	154-2865M13	154-2637M12			
		320	154-2841M12		154-2866M12	154-2866M13	154-2638M12			
		430	154-2842M12		154-2867M12	154-2867M13	154-2639M12			
		600	154B8962M12		154B9665M12	154B9665M13	154B9666M12			
RA210D	RF	70	154-2838M12	223.8	154-2863M12	154-2863M13	154-2635M12		213.8	
		140	154-2839M12		154-2864M12	154-2864M13	154-2636M12			
		210	154-2840M12		154-2865M12	154-2865M13	154-2637M12			
		320	154-2841M12		154-2866M12	154-2866M13	154-2638M12			
		430	154-2842M12		154-2867M12	154-2867M13	154-2639M12			
		600	154B8962M12		154B9665M12	154B9665M13	154B9666M12			

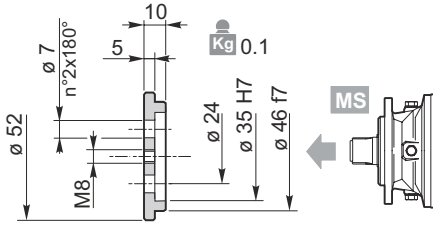
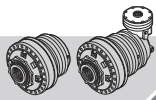

154-3063

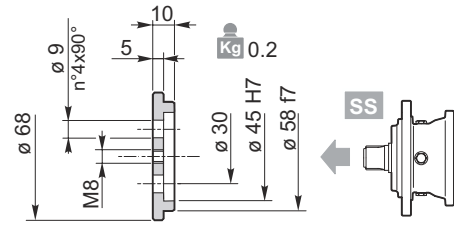

154-3061

Materiale / Material / Material / Matériau / Material / Material:
Acciaio / Steel / Stahl / Acier / Acero / Aço
C40 EN 10083-1 (1.1186)



Materiale / Material / Material / Matériau / Material / Material:
Acciaio / Steel / Stahl / Acier / Acero / Aço EN 10083-1-C40 (1.1186)

Trattamento termico:
 Tempra ad induzione secondo UNI 10932 su scanalato interno
Heat treatment:
 Induction hardening according to UNI 10932 on internal spline
Wärmebehandlung:
 Induktionshärtung nach UNI 10932 an interner Nut
Traitement thermique:
 Trempe par induction conformément à la norme UNI 10932 sur cannelé interne
Tratamiento térmico:
 Temple por inducción según UNI 10932 en acanalado interno
Tratamento térmico:
 Tempera por indução segundo UNI 10932 sobre ranhuras internas

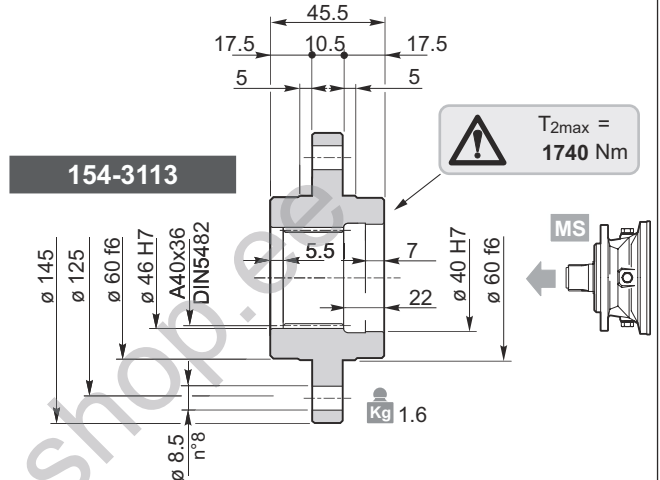

154-3113

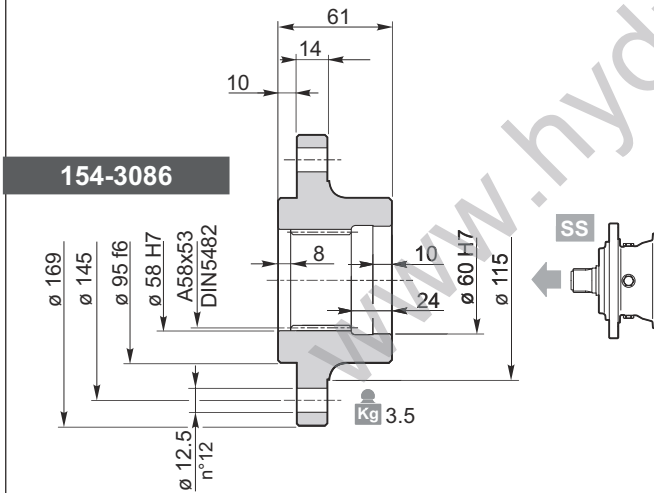

154-3086

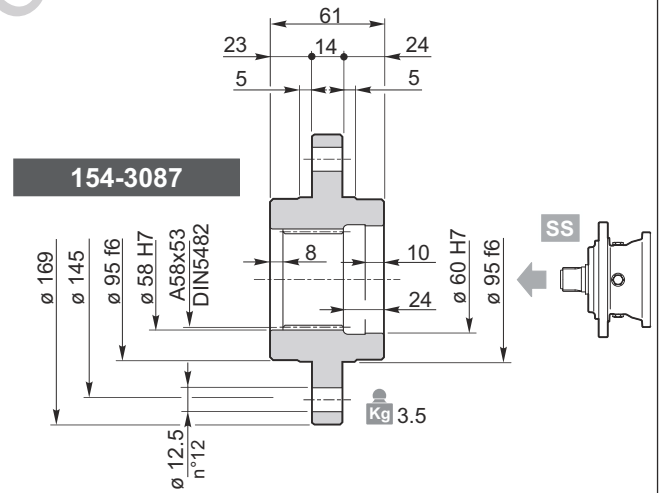

154-3087



Materiale / Material / Material / Matériau / Material / Material: **Acciaio / Steel / Stahl / Acier / Acero / Aço 39NiCrMo3 UNI 7845 (1.6511)**

Trattamento termico:
 Tempra ad induzione secondo UNI 10932 su scanalato interno
Heat treatment:
 Induction hardening according to UNI 10932 on internal spline
Wärmebehandlung:
 Induktionshärtung nach UNI 10932 an interner Nut

Traitement thermique:
 Trempe par induction conformément à la norme UNI 10932 sur cannelé interne
Tratamiento térmico:
 Temple por inducción según UNI 10932 en acanalado interno
Tratamento térmico:
 Tempera por indução segundo UNI 10932 sobre ranhuras internas

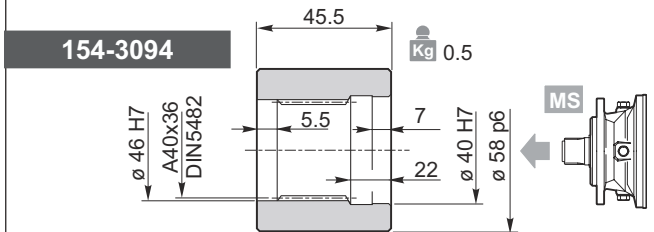

154-3094

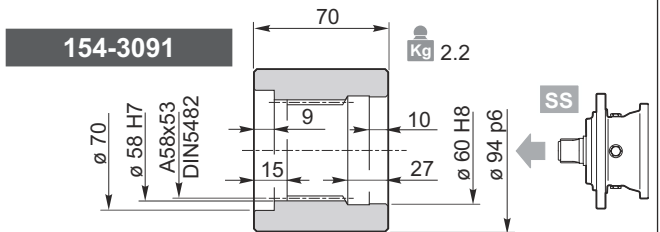

154-3091

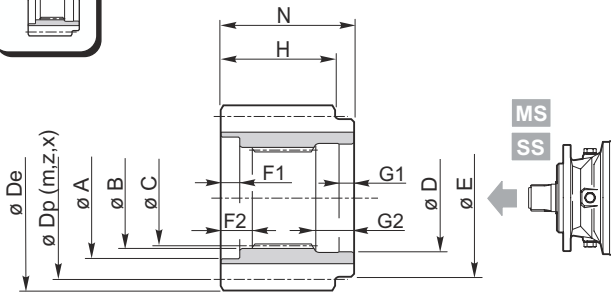
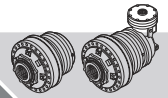

Materiale / Material / Material
 Matériau / Material / Material:
 Acciaio / Steel / Stahl / Acier / Acero / Aço
 39NiCrMo3 UNI 7845 (1.6511)

Trattamento termico:
 Tempra ad induzione secondo UNI 10932 su scanalato interno

Heat treatment:
 Induction hardening according to UNI 10932 on internal spline

Wärmebehandlung:
 Induktionshärtung nach UNI 10932 an interner Nut

Traitement thermique:
 Trempe par induction conformément à la norme UNI 10932 sur cannelé interne

Tratamiento térmico:
 Temple por inducción según UNI 10932 en acanalado interno

Tratamento térmico:
 Tempera por indução segundo UNI 10932 sobre ranhuras internas

	A	B	C	D	E	F1	F2	G1	G2	N	m	z	x	H	Dp	De	Code
MS	53	46 F6	DIN5482 A40x36	40 F6	50	2	7.5	7	21	47.5	4	15	0.5	44.5	60	69.8	154-3072
	53	46 F6	DIN5482 A40x36	40 F6	50	2	7.5	7	21	47.5	4	32	0	44.5	128	135	154-3104
	53	46 F6	DIN5482 A40x36	40 F6	50	2	7.5	7	21	47.5	6	12	0.25	44.5	72	84.8	154-3073
	53	46 F6	DIN5482 A40x36	40 F6	50	2	7.5	7	21	47.5	5	14	0.5	44.5	70	84	154-2709
	53	46 F6	DIN5482 A40x36	40 F6	50	2	7.5	7	21	47.5	6	24	0	44.5	144	154	154-2285
	53	46 F6	DIN5482 A40x36	40 F6	50	2	7.5	7	21	47.5	8	16	0.25	44.5	128	145	154-2707
SS	70	58 H7	DIN5482 A58x53	60 H7	72	7	13	12	27	68	4.5	18	0.4444	65	81	93	154-3106
	70	58 H7	DIN5482 A58x53	60 H7	68	7	13	10	27	68	5	17	0.4	65	85	98	154-2287
	70	58 H7	DIN5482 A58x53	60 H7	68	7	13	10	27	68	5	19	0	65	95	104	154-2286
	70	58 H7	DIN5482 A58x53	60 H7	75	7	13	12	27	68	6	14	0.5	65	84	101.5	154-3082
	70	58 H7	DIN5482 A58x53	60 H7	68	7	13	10	27	68	6	15	0.25	65	90	103	154-3107
	70	58 H7	DIN5482 A58x53	60 H7	68	7	13	10	27	68	6	16	0.25	65	96	109	154-3245
	70	58 H7	DIN5482 A58x53	60 H7	78	7	13	12	27	68	8	12	0.5	65	96	118	154-3074
	70	58 H7	DIN5482 A58x53	60 H7	68	7	13	10	27	68	8	14	0	65	112	126	154-3250
	70	58 H7	DIN5482 A58x53	60 H7	78	7	13	12	27	68	8	15	0	65	120	136	154-3246
	70	58 H7	DIN5482 A58x53	60 H7	68	7	13	10	27	68	8	15	0.25	65	120	138	154-3235
	70	58 H7	DIN5482 A58x53	60 H7	78	7	13	12	27	68	8	18	0	65	144	158	154-3103
	70	58 H7	DIN5482 A58x53	60 H7	78	7	13	12	27	68	10	10	0.25	65	100	124.5	154-3075
	70	58 H7	DIN5482 A58x53	60 H7	78	7	13	12	27	68	10	12	0.475	65	120	149.5	154-3105
	70	58 H7	DIN5482 A58x53	60 H7	68	7	13	10	27	68	10	15	0	65	150	167	154-3248

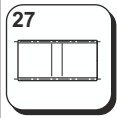

Kg 0.9

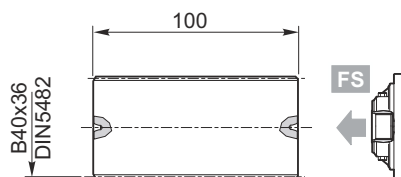

154-3050

Materiale / Materiale / Material
 Matériau / Material / Material:
 Acciaio / Steel / Stahl / Acier / Acero / Aço
 39NiCrMo3 UNI 7845 (1.6511)

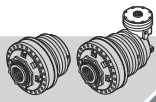

210

IT EN DE FR ES PT

RR	210	..	MS
RA			MC

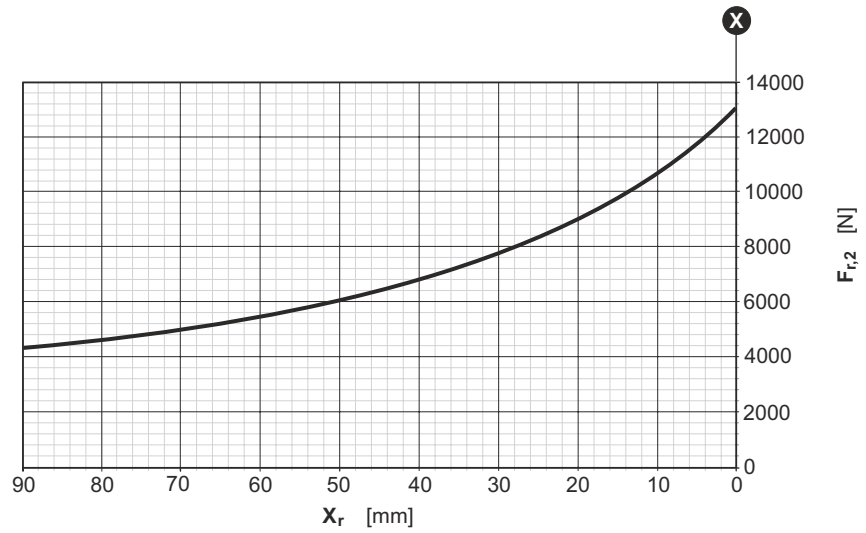
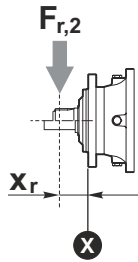

RR	210	..	SS
RA			SC

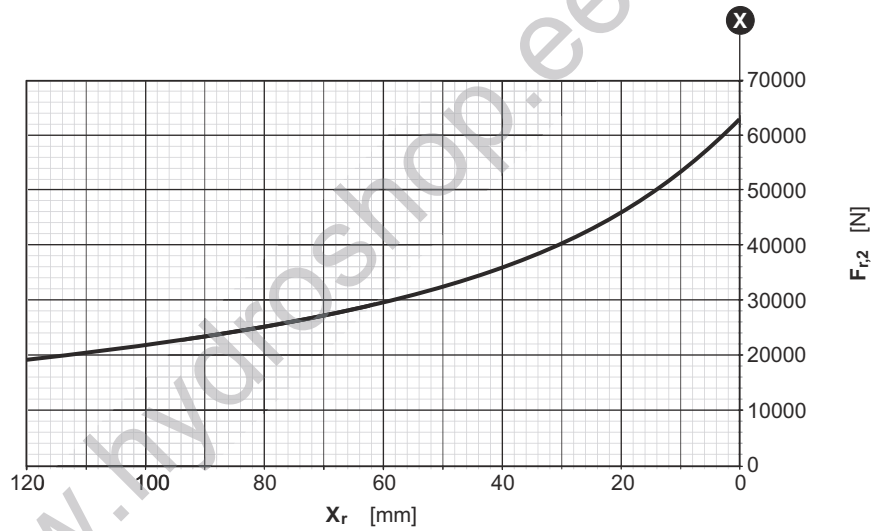
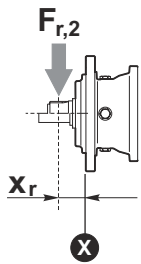

www.hydrosnop.ee

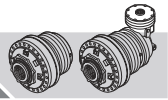

RR	210	..	UC
RA			

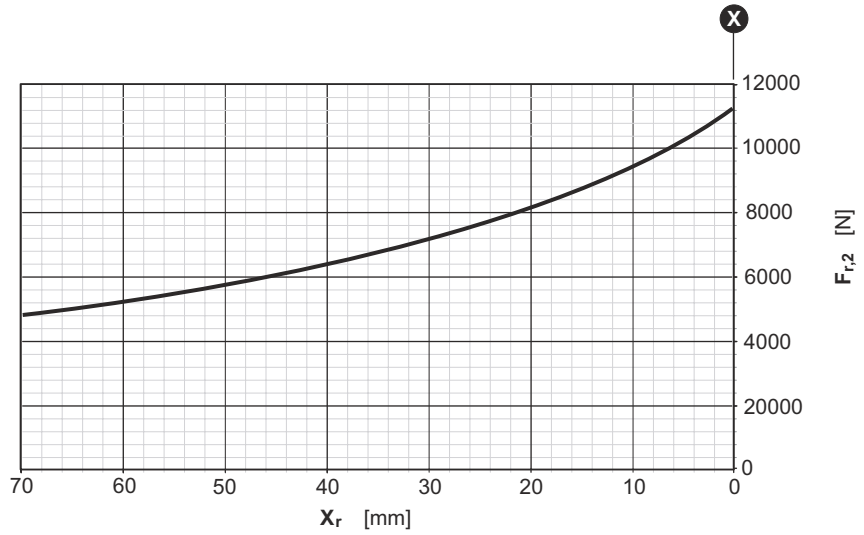
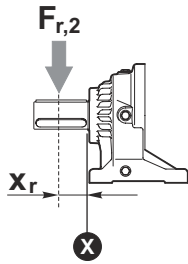

Fattore correttivo k_{r2} / k_{r2} Corrective coefficient / Korrekturfaktor k_{r2}
 Facteur correctif k_{r2} / Factor de corrección k_{r2} / Fator corretivo k_{r2}

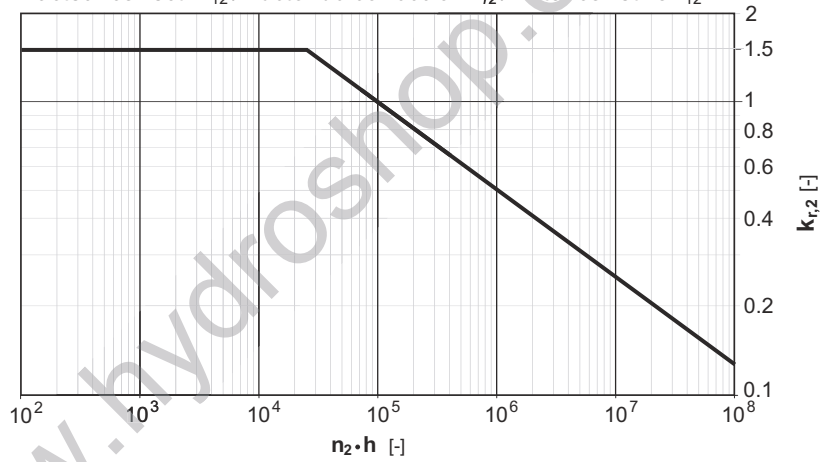

www.hydroshop.es